

MATRIX

MAGNUM SERIES

MG-A82





AUSTRALIA
Johnson Health Tech Australia
6B Hazelwood Drive
Morwell
VIC 3840 AUSTRALIA
Tel: +61 1300 760 601
au.matrixfitness.com

BRAZIL
Johnson Health Tech Brasil
Estrada Municipal, 200 – mód 14 e 15 – gleba 3
Chácara Alvorada
Indaiatuba, SP
CEP 13337-200 BRASIL
Tel: +55-19-2107-5300
br.matrixfitness.com

CANADA
Johnson Health Tech Canada
10401, Ray-Lawson Blvd.
Montreal, Quebec H1J 1M3
CANADA
Tel: 514-336-0006
www.matrixfitness.com

CHINA
Johnson Health Tech (Shanghai) Co., Ltd.
Rm 508-512
HuaWen Plaza 999 Zhongshan
(West) Road
Changning District
Shanghai, 200050 CHINA
Tel: +86-021-32503800
www.johnsonfitness.com.cn

FRANCE
Johnson Health Tech France
45, avenue Georges Politzer
Trappes
78190 FRANCE
Tel: +33 01 30 68 62 80
www.matrixfitness.fr

GERMANY / AUSTRIA
Johnson Health Tech. GmbH
Nikolaus-Otto-Str. 1
D-22946 Trittau GERMANY
Tel. +49 (0)4154-7952-0
www.matrixfitness.eu

GREECE
Johnson Health Tech Hellas SA
12 Vas. Konstantinou Avenue
116 35 Athens GREECE
Tel: +20 211 4112797
www.Johnson Health Tech.gr

HONG KONG
Johnson Health Tech (HK) Limited
Room 1501-1502, Aitken Vanson Centre,
61 Hoi Yuen Road, Kwun Tong
Kowloon
HONG KONG
Tel: +852-2302 0596
hk.matrixfitness.com

IBERIAN PENINSULA (SPAIN, PORTUGAL)
Johnson Health Tech Ibérica
Avenida de la Astronomía, 4 nave 9.2
San Fernando de Henares
28830 Madrid - ESPAÑA
Tel: +34-91 6293 688
www.matrixfitness.es

ITALY
Johnson Health Tech Italia Spa
Zona Ind.le Campolungo 11
63100 Ascoli Piceno (AP)
ITALY
Tel: +39 0736 22699
www.matrixfitness.it

JAPAN
Johnson Health Tech Japan
Yasuda Bldg. 2F,
3-3-8 Kaigan,
Minato-ku Tokyo 108-8435
JAPAN
Tel: +81-3-5419-3560
www.matrixfitness.jp

KOREA
Johnson Health Tech Co., Ltd. Korea Branch
203 ho, A-Block Richensia Young
San133-3 Wonhyoro 1-ga, Young San
Gu, 140-111 Seoul
SOUTH KOREA
Tel: +82-2-6731-0175
kr.matrixfitness.com

MALAYSIA
Johnson Fitness (Malaysia) Sdn. Bhd.
Lot 557D, Jalan Subang 3
Subang Jaya Industrial Estate
47610 Subang Jaya
Selangor MALAYSIA
Tel: +60-603-5632 8273
my.matrixfitness.com

NETHERLANDS (BELGIUM, DENMARK, LUXEMBOURG)
Matrix Fitness / Johnson Health Tech. Netherlands
Vleugelboot 14
3991 CL Houten
NETHERLANDS
Tel: +31 30 24 45 435
www.matrixfitness.nl

PHILIPPINES
Johnson Health Tech. Commercial Philippines Inc.
15th Floor, Citibank Center, 8741 Paseo de Roxas,
Makati City, Metro Manila, 1226 PHILIPPINES
Tel: +63-2-558-6590
world.matrixfitness.com

POLAND
Johnson Health Tech Poland
ul. Działkowa 62
02-234 Warszawa POLAND
Tel: +49 2234 9997-100
pl.matrixfitness.com

SWITZERLAND
Johnson Health Tech. (Schweiz) GmbH
Althardstrasse 185
CH-8105 Regensdorf SWITZERLAND
Tel. +41 (0)44-843 30 30
www.matrixfitness.ch

TAIWAN
Johnson Health Tech Taiwan
999, Sec 2, Dongda Rd., Daya Dist.,
Taichung City 428
TAIWAN (R.O.C)
Tel: +886-4-25667100
world.matrixfitness.com/zh

THAILAND
Johnson Health Tech Thailand
9th Floor, Unit 9B, Bangna Towers,
Tower A 2/3
Moo 14, Bangna-Trad Rd.
K.M. 6.5 Bangkaew, Pangplee
Samutprakan, 10540 THAILAND
Tel: +66-2751-9360
th.matrixfitness.com

UNITED ARAB EMIRATES
Johnson Health Tech. UAE
ICON Tower, Office #602
TECOM, Al Barsha
Dubai, United Arab Emirates
Tel: +971 4 4567939
world.matrixfitness.com/

UNITED KINGDOM
(ENGLAND, SCOTLAND, N. IRELAND, WALES)
Johnson Health Tech UK
Riverside park
Campbell Road
Stoke on Trent
ST4 4EY ENGLAND
Tel: +44-1782644900
www.matrixfitness.co.uk

UNITED STATES
Matrix Fitness / Johnson Health Tech NA
1600 Landmark Drive
Cottage Grove, WI 53527 USA
Toll Free: +1-866-693-4863
www.matrixfitness.com

VIETNAM
Johnson Health Tech (Vietnam) Co. Ltd.
Unit 2302, Lim Tower
9-11 Ton Duc Thang Street
Ben Nghe Ward, District 1
Ho Chi Minh City
VIETNAM
Tel: +84 909 977957
vn.matrixfitness.com

INTERNATIONAL (OTHER COUNTRIES)
Matrix Fitness International
999, Sec 2, Dongda Rd., Daya Dist.,
Taichung City 428
TAIWAN (R.O.C)
Tel: +886-4-25667100
world.matrixfitness.com



IMPORTANT SAFETY INFORMATION

It is the sole responsibility of the purchaser of MATRIX products to instruct all individuals, whether they are the end user or supervising personnel on proper usage of the equipment.

It is recommended that all users of MATRIX exercise equipment be informed of the following information prior to its use.

Do not use any equipment in any way other than designed or intended by the manufacturer. It is imperative that MATRIX equipment be used properly to avoid injury.

INSTALLATION

1. **STABLE AND LEVEL SURFACE:** MATRIX exercise equipment must be installed on a stable base and properly leveled.
2. **SECURING EQUIPMENT:** Manufacturer recommends that all stationary MATRIX strength equipment be secured to the floor to stabilize equipment and eliminate rocking or tipping over. This must be performed by a licensed contractor.

All anchor points must be able to withstand 750 lbs. (3.3 kN) pull-out force.

MAINTENANCE

1. **DO NOT** use any equipment that is damaged and or has worn or broken parts. Use only replacement parts supplied by your country's local MATRIX dealer.
2. **MAINTAIN LABELS AND NAMEPLATES:** Do not remove labels for any reason. They contain important information. If unreadable or missing, contact your MATRIX dealer for a replacement.
3. **MAINTAIN ALL EQUIPMENT:** Preventative maintenance is the key to smooth operating equipment as well as keeping your liability to a minimum. Equipment needs to be inspected at regular intervals.
4. Ensure that any person(s) making adjustments or performing maintenance or repair of any kind is qualified to do so. MATRIX dealers will provide service and maintenance training at our corporate facility upon request.

ADDITIONAL NOTES

This equipment should only be used in supervised areas where access and control is specifically regulated by the owner. It is up to the owner to determine who is allowed access to this training equipment. The owner should consider a user's: degree of reliability, age, experience, etc.

This training equipment meets industry standards for stability when used for its intended purpose in accordance with the instructions provided by the manufacturer.

This training equipment is in compliance with EN 957-1 and the relevant portions of EN 957-2 and EN 957-4.

WARNING

DEATH OR SERIOUS INJURY CAN OCCUR ON THIS EQUIPMENT. FOLLOW THESE PRECAUTIONS TO AVOID INJURY!

1. Keep children under the age of 14 away from this strength training equipment. Teenagers must be supervised at all times while using this equipment.
2. This equipment is not intended for use by persons with reduced physical, sensory or mental capabilities, or lack of experience and knowledge, unless they have been given supervision or instruction concerning use of the equipment by a person responsible for their safety.
3. All warnings and instructions should be read and proper instruction obtained prior to use. Use this equipment for its intended purpose ONLY.
4. Inspect the machine before use. DO NOT use machine if it appears damaged or inoperable.
5. Do not exceed weight capacity of this equipment.
6. Check to see that the selector pin is completely inserted into the weight stack.
7. NEVER use the machine with the weight stack pinned in an elevated position.
8. NEVER use dumbbells or other means to incrementally increase the weight resistance. Only use the means provided directly from the manufacturer.
9. Injuries to health may result from incorrect or excessive training. Cease exercise if you feel faint or dizzy. Obtain a medical exam before beginning an exercise program.
10. Keep body, clothing, hair, and fitness accessories free and clear of all moving parts.
11. Adjustable stops, where provided, must be used at all times.
12. When adjusting any adjustable mechanism (stop position, seat position, pad location, range of motion limiter, pulley carriage, or any other type), make certain that the adjustable mechanism is fully engaged prior to use to prevent unintended motion.
13. Manufacturer recommends that this equipment be secured to the floor to stabilize and eliminate rocking or tipping over. Use a licensed contractor.
14. If equipment is NOT secured to floor: NEVER allow resistance straps, ropes or other means to be attached to this equipment, as this may result in serious injury. NEVER use this equipment for support during stretching, as this may result in serious injury.
15. DO NOT REMOVE THIS LABEL. REPLACE IF DAMAGED OR ILLEGIBLE.



PROPER USAGE

1. Do not exceed weight limits of the exercise device.
2. If applicable, set safety stops to appropriate height.
3. If applicable, adjust seat pads, leg pads, foot pads, range of motion adjustment, or any other type of adjustment mechanisms to a comfortable start position. Make certain that the adjusting mechanism is fully engaged to prevent unintentional movement and to avoid injury.
4. Sit on bench (if applicable) and get into appropriate position for exercise.
5. Exercise using no more weight than you can safely lift and control.
6. In a controlled manner, perform exercise.
7. Return weight to its fully-supported start position.

MAINTENANCE CHECKLIST	
ACTION	FREQUENCY
Clean Upholstery *	Daily
Inspect Cables	Daily
Clean Guide Rods	Monthly
Inspect Hardware	Monthly
Inspect Frame	Bi-Annually
Clean Machine	As Needed
Clean Grips *	As Needed
Lubricate Guide Rods †	As Needed

* Upholstery & Grips should be cleaned with a mild soap and water or a non-ammonia based cleaner.

† Guide rods should be lubricated with Teflon based lubricant. Apply the lubricant to a cotton cloth and then apply up and down the guide rods.

WARRANTY

For North America, please visit www.matrixfitness.com for warranty information along with warranty exclusions and limitations.

PRODUCT SPECIFICATIONS	
Maximum User Weight	159 kg / 350 lbs.
Maximum Training Weight	272 kg / 600 lbs.
Product Weight	55 kg / 121.5 lbs.
Overall Dimensions (L x W x H)*	152 x 78 x 46 cm / 59.7" x 30.6" x 17.8"

* Ensure a minimum clearance width of 0.6 meters (24") for access to and passage around MATRIX strength equipment. Please note, 0.91 meters (36") is the ADA recommended clearance width for individuals in wheelchairs.



UNPACKING

Thank you for purchasing a MATRIX Fitness product. It is inspected before it is packaged. It is shipped in multiple pieces to facilitate the compact packaging of the machine. Prior to assembly, confirm all the components by matching them with the exploded diagrams. Carefully unpack the unit from this box and dispose of the packing materials in accordance with your local laws.

CAUTION

To avoid injury to yourself and prevent damage to the frame components, be sure to have proper assistance removing the frame pieces from this box. Please be sure to install the equipment on a stable base, and properly level the machine. Ensure a minimum clearance width of 0.6 meters (24") for access to and passage around MATRIX strength equipment. Please note, 0.91 meters (36") is the ADA recommended clearance width for individuals in wheelchairs.

TOOLS REQUIRED FOR ASSEMBLY (not included)

3MM L-Shaped Allen Wrench



4MM L-Shaped Allen Wrench



5MM L-Shaped Allen Wrench



6MM L-Shaped Allen Wrench



8MM L-Shaped Allen Wrench



10MM L-Shaped Allen Wrench

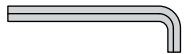

Phillips Screwdriver



8MM Open-End Wrench



17MM Open-End Wrench



Guide Rod Lubrication



If any items are missing please contact your country's local MATRIX dealer for assistance.

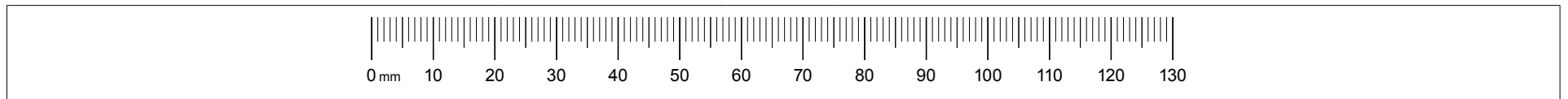

Hardware

	Description	Qty
Z15	Screw (M10X75L)	1
Z16	Screw (M10X30L)	6
Z17	Flat Washer (Φ10)	7
Z18	Spring Washer (Φ12)	3
Z19	Screw (M12X105L)	3
Z20	Curve Washer (Φ12)	6
Z21	Nylon Nut (M12)	3

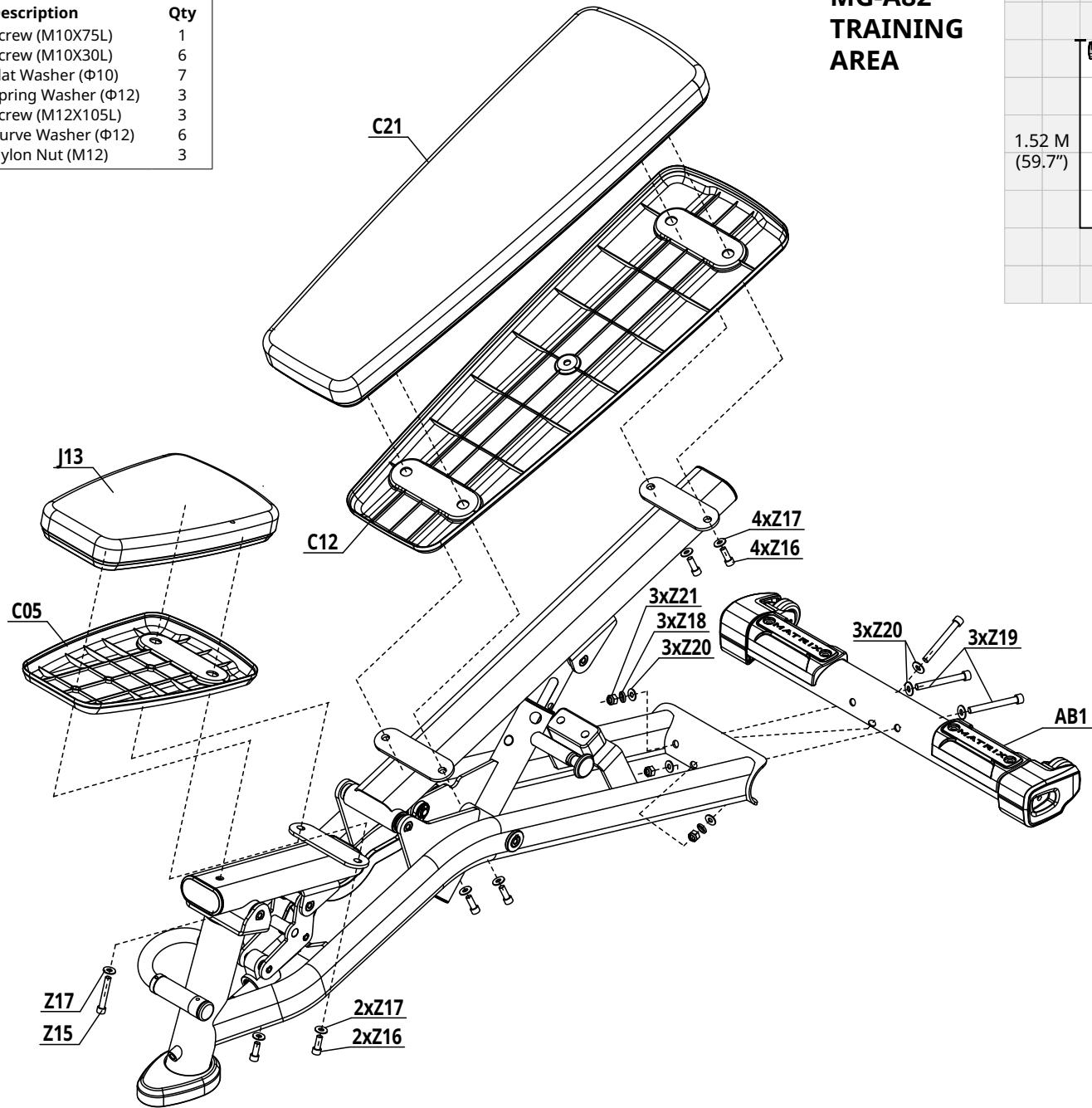

**MG-A82
TRAINING
AREA**

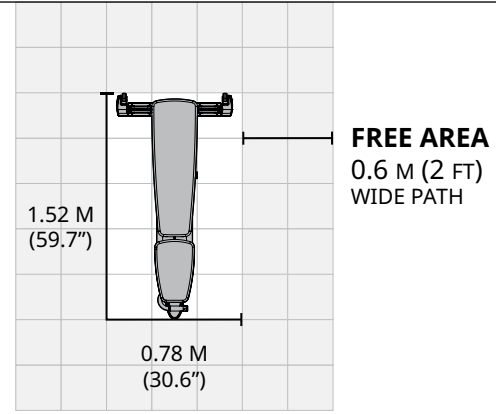

MATRIX