



MAGNUM SERIES
MG-PL76 STANDING CALF

MATRIX

MATRIX
Strong • Smart • Beautiful

MATRIX FITNESS | 1600 LANDMARK DRIVE COTTAGE GROVE WI 53527 USA
Toll Free 866.693.4863 | matrixfitness.com | Fax 608.839.8687

PART # MH0204528B

REV. 1.5

IMPORTANT SAFETY INFORMATION

It is the sole responsibility of the purchaser of MATRIX products to instruct all individuals, whether they are the end user or supervising personnel on proper usage of the equipment.

It is recommended that all users of MATRIX exercise equipment be informed of the following information prior to its use.

Do not use any equipment in any way other than designed or intended by the manufacturer.

It is imperative that MATRIX equipment be used properly to avoid injury.

INSTALLATION

- STABLE AND LEVEL SURFACE:** MATRIX exercise equipment must be installed on a stable base and properly leveled.
- SECURING EQUIPMENT:** Manufacturer recommends that all stationary MATRIX strength equipment be secured to the floor to stabilize equipment and eliminate rocking or tipping over. This must be performed by a licensed contractor.
 - All anchor points must be able to withstand 750 lbs. (3.3 kN) pull-out force.

MAINTENANCE

- DO NOT use any equipment that is damaged and/or has worn or broken parts. Use only replacement parts supplied by your country's local MATRIX dealer.
- MAINTAIN LABELS AND NAMEPLATES:** Do not remove labels for any reason. They contain important information. If unreadable or missing, contact your MATRIX dealer for a replacement.
- MAINTAIN ALL EQUIPMENT:** Preventative maintenance is the key to smooth operating equipment as well as keeping your liability to a minimum. Equipment needs to be inspected at regular intervals.
- Ensure that any person(s) making adjustments or performing maintenance or repair of any kind is qualified to do so. MATRIX dealers will provide service and maintenance training at our corporate facility upon request.

ADDITIONAL NOTES

This equipment should only be used in supervised areas where access and control is specifically regulated by the owner. It is up to the owner to determine who is allowed access to this training equipment. The owner should consider a user's: degree of reliability, age, experience, etc.

This training equipment meets industry standards for stability when used for its intended purpose in accordance with the instructions provided by the manufacturer.

This equipment is for indoor use only. This training equipment is a Class S product (designed for use in a commercial environment such as a fitness facility). This training equipment is in compliance with EN ISO 20957-1 and EN ISO 20957-2.

PROPER USAGE

- Do not exceed weight limits of the exercise device.
- If applicable, set safety stops to appropriate height.
- If applicable, adjust seat pads, leg pads, foot pads, range of motion adjustment, or any other type of adjustment mechanisms to a comfortable start position. Make certain that the adjusting mechanism is fully engaged to prevent unintentional movement and to avoid injury.
- Sit on bench (if applicable) and get into appropriate position for exercise.
- Exercise using no more weight than you can safely lift and control.
- In a controlled manner, perform exercise.
- Return weight to its fully-supported start position.

MAINTENANCE CHECKLIST

ACTION	FREQUENCY
Clean Upholstery *	Daily
Inspect Cables	Daily
Clean Guide Rods	Monthly
Inspect Hardware	Monthly
Inspect Frame	Bi-Annually
Clean Machine	As Needed
Clean Grips *	As Needed
Lubricate Guide Rods †	As Needed

* Upholstery & Grips should be cleaned with a mild soap and water or a non-ammonia based cleaner.

† Guide rods should be lubricated with Teflon based lubricant. Apply the lubricant to a cotton cloth and then apply up and down the guide rods.

PRODUCT SPECIFICATIONS

TECH SPECS	
Max. User Weight	159 kg / 350 lbs
Max. Training Weight	245 kg / 540 lbs
Product Weight	124 kg / 273.5 lbs
Overall Dimensions (L x W x H)*	138 x 89 x 184.5 cm / 54.5" x 35" x 73"
Starting Resistance	30.4 kg / 67 lbs
Weight Horn Diameter (Working Arms)	5 cm / 1.97"

* Ensure a minimum clearance width of 0.6 meters (24") for access to and passage around MATRIX strength equipment. Please note, 0.91 meters (36") is the ADA recommended clearance width for individuals in wheelchairs.

WARRANTY

VALID IN NORTH AMERICA ONLY	
Frame (not coatings) *	10 years
Weight stacks	5 years
Pulleys	5 years
Pivot bearings	5 years
Any items not specified	3 years
Labor (excluding upholstery/cables/grips)	3 years
Upholstery/cables/grips/springs	1 year
Accessories	6 months

* Frame is defined as the welded metal base of the unit and does not include removable parts. Product specifications subject to change without notice.

WARNING

DEATH OR SERIOUS INJURY CAN OCCUR ON THIS EQUIPMENT. FOLLOW THESE PRECAUTIONS TO AVOID INJURY!

- Keep children under the age of 14 away from this strength training equipment. Teenagers must be supervised at all times while using this equipment.
- This equipment is not intended for use by persons with reduced physical, sensory or mental capabilities, or lack of experience and knowledge, unless they have been given supervision or instruction concerning use of the equipment by a person responsible for their safety.
- All warnings and instructions should be read and proper instruction obtained prior to use. Use this equipment for its intended purpose ONLY.
- Inspect the machine before use. DO NOT use machine if it appears damaged or inoperable.
- Do not exceed weight capacity of this equipment.
- ALWAYS use a spotter if using free weights.
- Balance the weight applied to this equipment and/or any barbell. Where applicable, use retention devices to retain weight discs.
- Injuries to health may result from incorrect or excessive training. Cease exercise if you feel faint or dizzy. Obtain a medical exam before beginning an exercise program.
- Keep body, clothing, hair, and fitness accessories free and clear of all moving parts.
- Adjustable stops, where provided, must be used at all times.
- When adjusting any adjustable mechanism (stop position, seat position, pad location, range of motion limiter, pulley carriage, or any other type), make certain that the adjustable mechanism is fully engaged prior to use to prevent unintended motion.
- Manufacturer recommends that this equipment be secured to the floor to stabilize and eliminate rocking or tipping over. Use a licensed contractor.
- If equipment is NOT secured to floor, NEVER allow resistance straps, ropes or other means to be attached to this equipment, as this may result in serious injury. NEVER use this equipment for support during stretching, as this may result in serious injury.
- DO NOT REMOVE THIS LABEL. REPLACE IF DAMAGED OR ILLEGIBLE.

Plate-loaded / Free Weight

EXCLUSIVE REMEDY

The exclusive remedy for any of the above warranties shall be repair or replacement of defective Parts, or the supply of Labor to cure any defect, per the terms of the Commercial Warranty. All Labor shall be supplied by the local Matrix certified technician. The Product must be located within that service provider's service area. Products located outside service area will not be covered by the Labor warranty.

EXCLUSIONS AND LIMITATIONS

- This warranty applies only to the original owner and is not transferable.
- Under no circumstances will MATRIX FITNESS be liable by virtue of this warranty or otherwise for damage to any person or property whatsoever for any special, indirect, incidental, secondary or consequential losses, damages or expenses in connection with exercise products.
- This warranty is expressly limited to the repair or replacement of a defective Frame or Part. Repair or replacement will be at the discretion of MATRIX FITNESS, and is the sole remedy of the warranty.
- Do not use equipment in any location that is not climate controlled, such as but not limited to garages, porches, pool rooms, saunas, bathrooms, car ports or outdoors. Failure to comply may void the warranty.
- This warranty does not cover normal wear and tear – including but not limited to: cuts in upholstery, damage caused externally that is not due to a manufacturer defect, improper assembly or maintenance, or installation of parts or accessories not originally intended or compatible with the MATRIX FITNESS Product as sold.
- This warranty does not cover damage or failure due to accident, abuse, corrosion, discoloration of paint or plastic, neglect, theft, vandalism, fire, flood, wind, lightning, freezing, or other natural disasters of any kind, power reduction, fluctuation or failure from whatever cause, unusual atmospheric conditions, collision, introduction of foreign objects into the covered unit, or modifications that are unauthorized or not recommended by MATRIX FITNESS.
- Parts reconditioned to As New Condition by MATRIX FITNESS or its vendors may sometimes be supplied as warranty replacement parts and constitute fulfillment of warranty terms. Any warranty replacement parts shall be warranted for the remainder of the original warranty term.

This warranty shall NOT apply to the following:

- Failure to provide reasonable and necessary maintenance as outlined in the Owner's Manual.
- Software limitations and upgrades.
- Batteries or other consumable goods.
- Cosmetic items.
- Repairs performed on equipment missing a serial number or with a serial number tag that has been altered or removed.
- Service calls to correct installation of the equipment or instructing on use of equipment.
- Pick-up, delivery or freight charges involved with repairs.
- Any labor charges incurred beyond the applicable labor warranty.

MATRIX FITNESS expressly disclaims all other warranties, express or implied, including but not limited to all warranties of fitness for a particular purpose or of merchantability. This warranty gives you specific legal rights, and your rights may vary from state to state.

MAGNUM SERIES (MG-PL76) STANDING CALF











UNPACKING (MG-PL76) STANDING CALF

Thank you for purchasing a MATRIX Fitness product. Your MAGNUM SERIES (MG-PL76) STANDING CALF is inspected before it is packaged. It is shipped in multiple pieces to facilitate the compact packaging of the machine. Prior to assembly, confirm all the components by matching them with the exploded diagrams. Carefully unpack the unit from this box and dispose of the packing materials in accordance with your local laws.

CAUTION

To avoid injury to yourself and prevent damage to the frame components, be sure to have proper assistance removing the frame pieces from this box. Please be sure to install the equipment on a stable base and properly level the machine. Ensure a minimum clearance width of 0.6 meters (24") for access to and passage around MATRIX strength equipment. Please note, 0.91 meters (36") is the ADA recommended clearance width for individuals in wheelchairs.

TOOLS REQUIRED FOR ASSEMBLY (NOT INCLUDED)

3MM L-Shaped Allen Wrench		10MM L-Shaped Allen Wrench	
4MM L-Shaped Allen Wrench		Phillips Screwdriver	
5MM L-Shaped Allen Wrench		8MM Open-End Wrench	
6MM L-Shaped Allen Wrench		17MM Open-End Wrench	
8MM L-Shaped Allen Wrench		Guide Rod Lubrication	

If any items are missing please contact your country's local MATRIX dealer for assistance.

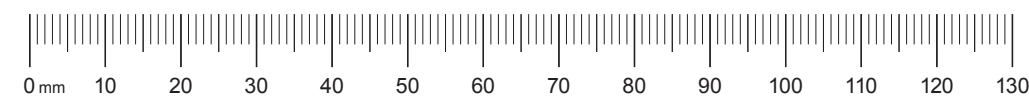

PLACARD

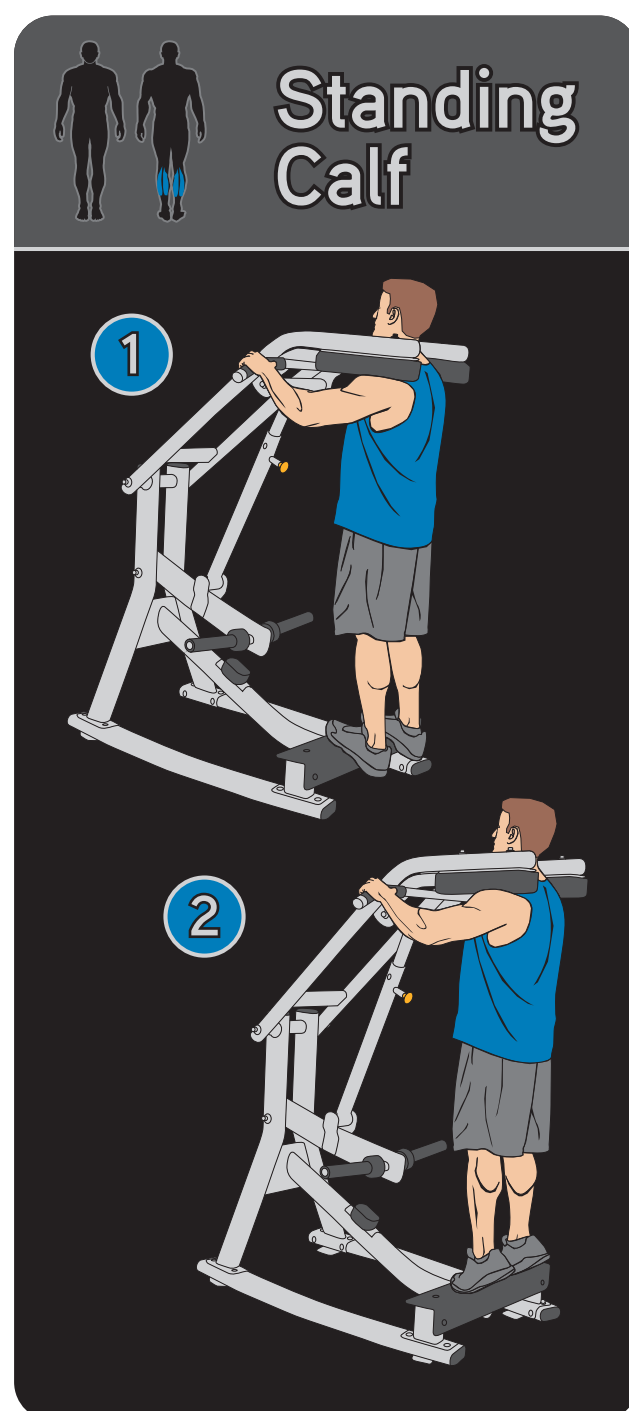

FOOTPRINT AREA

PL76 TRAINING AREA

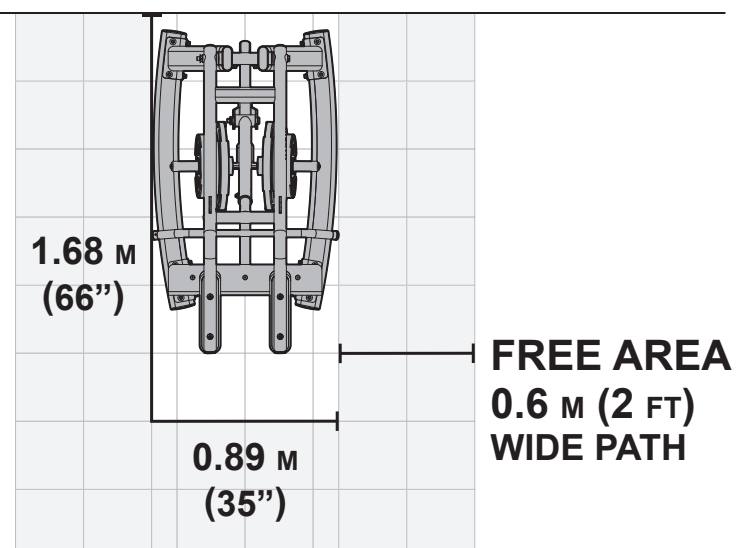

Step 1

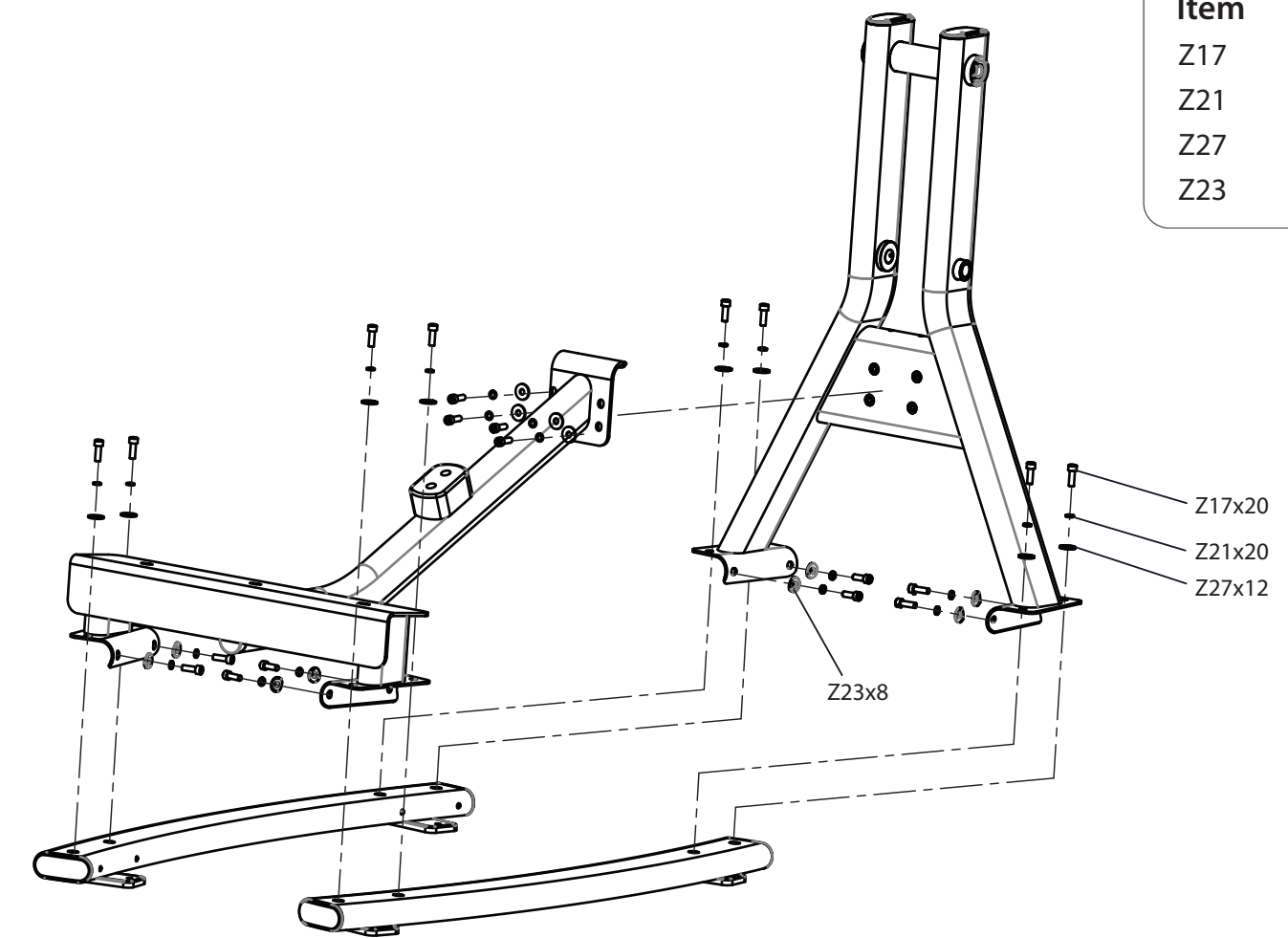

Frame Detail

Item	Description	Qty
Z17	Screw (M10x25L)	20
Z21	Washer;SPL (Ø10)	20
Z27	Flat Washer (Ø10)	12
Z23	Washer;Arc (M10)	8

Step 2

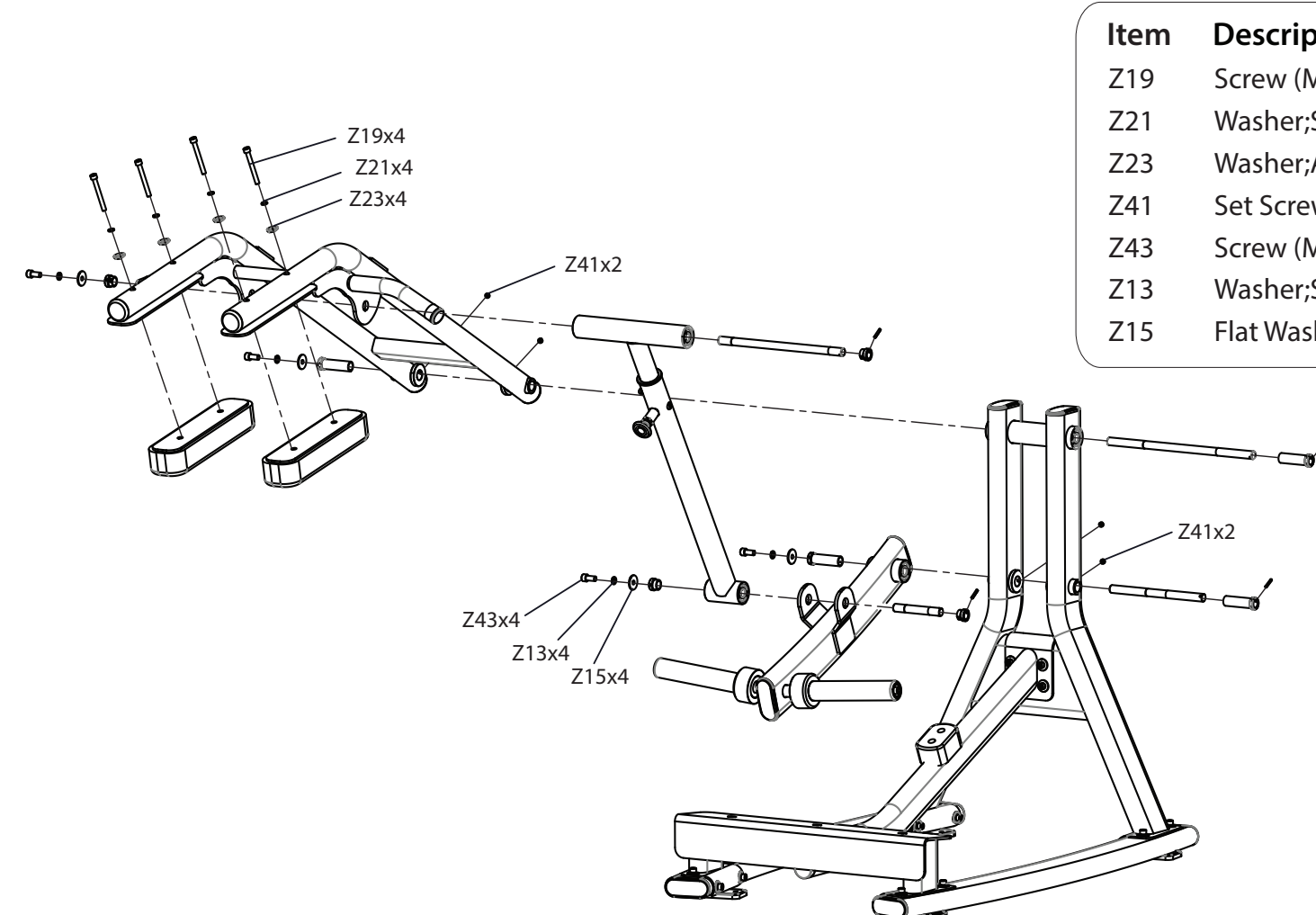

Frame Detail

Item	Description	Qty
Z19	Screw (M10x90L)	4
Z21	Washer;SPL (Ø10)	4
Z23	Washer;Arc (Ø10)	4
Z41	Set Screw (M6x4L)	4
Z43	Screw (M12x25L)	4
Z13	Washer;SPL (Ø12)	4
Z15	Flat Washer (Ø13)	4