

MATRIX

UPRIGHT CYCLE



ONYX



# IMPORTANT PRECAUTIONS

## SAVE THESE INSTRUCTIONS

When using Matrix exercise equipment, basic precautions should always be followed, including the following: Read all instructions before using this equipment. It is the responsibility of the owner to ensure that all users of this equipment are adequately informed of all warnings and precautions.

This equipment is for indoor use only. This training equipment is a Class S product designed for use in a commercial environment such as a fitness facility.

This equipment is for use only in a climate-controlled room. If your exercise equipment has been exposed to colder temperatures or high moisture climates, it is strongly recommended that this equipment is warmed up to room temperature prior to use.

## DANGER!

### TO REDUCE THE RISK OF ELECTRICAL SHOCK:

Always unplug the equipment from the electrical outlet before cleaning, performing maintenance and putting on or taking off parts.

## WARNING!

### TO REDUCE THE RISK OF BURNS, FIRE, ELECTRICAL SHOCK OR INJURY TO PERSONS:

- Use this equipment only for its intended use as described the equipment's Owner's Manual.
- At NO time should children under the age of 14 use the equipment.
- At NO time should pets or children under the age of 14 be closer to the equipment than 10 feet / 3 meters.
- This equipment is not intended for use by persons with reduced physical, sensory or mental capabilities, or lack of experience and knowledge, unless they are supervised or have been given instruction concerning use of the equipment by a person responsible for their safety.
- Always wear athletic shoes while using this equipment. NEVER operate the exercise equipment with bare feet.
- Do not wear any clothing that might catch on any moving parts of this equipment.
- Heart rate monitoring systems may be inaccurate. Over exercising may result in serious injury or death.
- Incorrect or excessive exercise may result in serious injury or death. If you experience any kind of pain, including but not limited to chest pains, nausea, dizziness, or shortness of breath, stop exercising immediately and consult your physician before continuing.
- Do not jump on the equipment.
- At no time should more than one person be on the equipment.
- Set up and operate this equipment on a solid level surface.
- Never operate the equipment if it is not working properly or if it has been damaged.
- Use handlebars to maintain balance when mounting and dismounting, and for additional stability while exercising.
- To avoid injury, do not expose any body parts (for example, fingers, hands, arms or feet) to the drive mechanism or other potentially moving parts of the equipment.
- Connect this exercise product to a properly grounded outlet only.
- This equipment should never be left unattended when plugged in. When not in use, and prior to servicing, cleaning, or moving equipment, turn off power, then unplug from outlet.
- Do not use any equipment that is damaged or has worn or broken parts. Use only replacement parts supplied by Customer Technical Support or an authorized dealer.
- Never operate this equipment if it has been dropped, damaged, or is not working properly, has a damaged cord or plug, is located in a damp or wet environment, or has been immersed in water.
- Keep power cord away from heated surfaces. Do not pull on this power cord or apply any mechanical loads to this cord.
- Do not remove any protective covers unless instructed by Customer Technical Support. Service should only be done by an authorized service technician.
- To prevent electrical shock, never drop or insert any object into any opening.
- Do not operate where aerosol (spray) products are being used or when oxygen is being administered.
- This equipment should not be used by persons weighing more than the specified maximum weight capacity as listed in the equipment Owner's Manual. Failure to comply will void the warranty.
- This equipment must be used in an environment that is both temperature and humidity controlled. Do not use this equipment in locations such as, but not limited to: outdoors, garages, car ports, porches, bathrooms, or located near a swimming pool, hot tub, or steam room. Failure to comply will void the warranty.
- Contact Customer Technical Support or an authorized dealer for examination, repair and/or service.
- Never operate this exercise equipment with the air opening blocked. Keep the air opening and internal components clean, free of lint, hair, and the like.
- Do not modify this exercise device or use unapproved attachments or accessories. Modifications to this equipment or use of unapproved attachments or accessories will void your warranty and may cause injury.
- To clean, wipe surfaces down with soap and slightly damp cloth only; never use solvents. (See MAINTENANCE)
- Use the stationary training equipment in a supervised environment.
- Individual human power to perform exercise may be different than the mechanical power displayed.
- When exercising, always maintain a comfortable and controlled pace.
- Do not attempt to ride the exercise cycle in a standing position.



## POWER REQUIREMENTS

### CAUTION!

This equipment is for indoor use only. This training equipment is a Class S product designed for use in a commercial environment such as a fitness facility.

1. Do not use this equipment in any location that is not temperature controlled, such as but not limited to garages, porches, pool rooms, bathrooms, car ports or outdoors. Failure to comply may void the warranty.
2. It is essential that this equipment is used only indoors in a climate controlled room. If this equipment has been exposed to colder temperatures or high moisture climates, it is strongly recommended that the equipment is warmed up to room temperature and allowed time to dry out before first time use.
3. Never operate this equipment if it has been dropped, damaged, or is not working properly, has a damaged cord or plug, is located in a damp or wet environment, or has been immersed in water.

### ELECTRICAL REQUIREMENTS

Any alterations to the standard power cord provided could void all warranties of this product.

For units with an integrated TV (ONYX), the TV power requirements are included in the unit. An RG6 quad shield coaxial cable with 'F Type' compression fittings on each end will need to be connected to the cardio unit and the video source. Additional power requirements are not needed for the add-on digital TV.

### 120 V UNITS

Units require nominal 120 VAC, 50-60 Hz and at least a 15 A circuit with a dedicated neutral and dedicated ground wires with no more than 4 units per circuit. The electrical outlet must have a ground connection and have the same configuration as the plug included with the unit. No adapter should be used with this product.

### 220-240 V UNITS

Units require nominal 220-240 VAC, 50-60 Hz and at least a 10 A circuit with a dedicated neutral and dedicated ground wires with no more than 4 units per circuit. The electrical outlet must have a ground connection and have the same configuration as the plug included with the unit. No adapter should be used with this product.

### GROUNDING INSTRUCTIONS

The unit must be grounded. If it should malfunction or breakdown, grounding provides a path of least resistance for electric current to reduce the risk of electric shock. The unit is equipped with a cord having an equipment-grounding conductor and a grounding plug. The plug must be plugged into an appropriate outlet that is properly installed and grounded in accordance with all local codes and ordinances. If the user does not follow these grounding instructions, the user could void the Matrix limited warranty.

### ENERGY SAVING / LOW-POWER MODE

All units are configured with the ability to enter into an energy saving / low-power mode when the unit has not been in use for a specified period of time. Additional time may be required to fully reactivate this unit once it has entered the low-power mode. This energy saving feature may be enabled or disabled from within the 'Manager Mode' or 'Engineering Mode.'



# ASSEMBLY

## UNPACKING

Unpack the equipment where you will be using it. Place the carton on a level flat surface. It is recommended that you place a protective covering on your floor. Never open box when it is on its side.

## IMPORTANT NOTES

During each assembly step, ensure that ALL nuts and bolts are in place and partially threaded.

Several parts have been pre-lubricated to aid in assembly and usage. Please do not wipe this off. If you have difficulty, a light application of lithium grease is recommended.

## WARNING!

There are several areas during the assembly process that special attention must be paid. It is very important to follow the assembly instructions correctly and to make sure all parts are firmly tightened. If the assembly instructions are not followed correctly, the equipment could have parts that are not tightened and will seem loose and may cause irritating noises. To prevent damage to the equipment, the assembly instructions must be reviewed and corrective actions should be taken.

## NEED HELP?

If you have questions or if there are any missing parts, contact Customer Tech Support. Contact information is located on the information card.

## TOOLS REQUIRED:

- 4 mm Allen Wrench
- 6 mm Allen Wrench
- Flat Wrench (15mm/17mm 325L)
- Phillips Screwdriver

## PARTS INCLUDED:

- 1 Main Frame
- 1 Rear Stabilizer Tube
- 1 Front Stabilizer Tube
- 1 Console Mast Assembly
- 1 Console Base Assembly
- 1 Handlebar Set
- 2 Pedals
- 1 Hardware Kit
- 1 Power Cord

Console sold separately

# ASSEMBLY

1	Pre-installed	Qty
A	Screw (M5x12L)	2

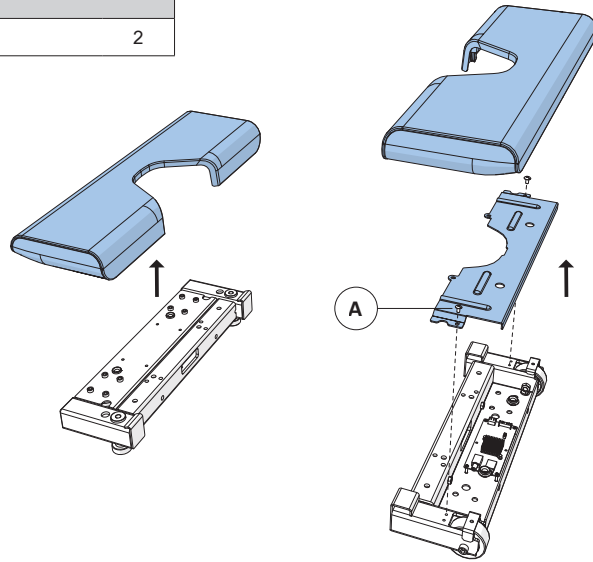

3	Hardware	Qty
B	Bolt (M8x70L)	6
C	Flat Washer (M8)	6

**Torque Value**  
40 Nm / 29 ft-lb

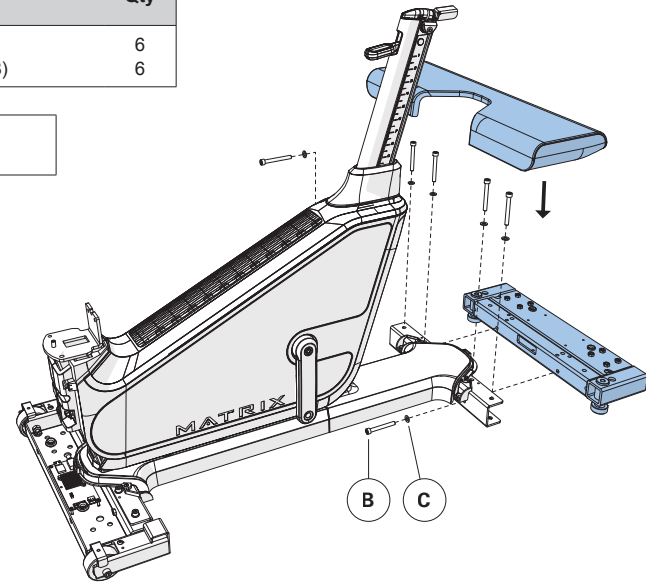

2	Hardware	Qty
B	Bolt (M8x70L)	6
C	Flat Washer (M8)	6

**Torque Value**  
40 Nm / 29 ft-lb

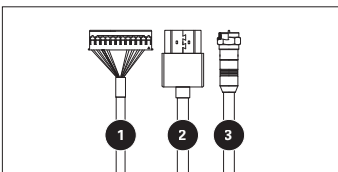
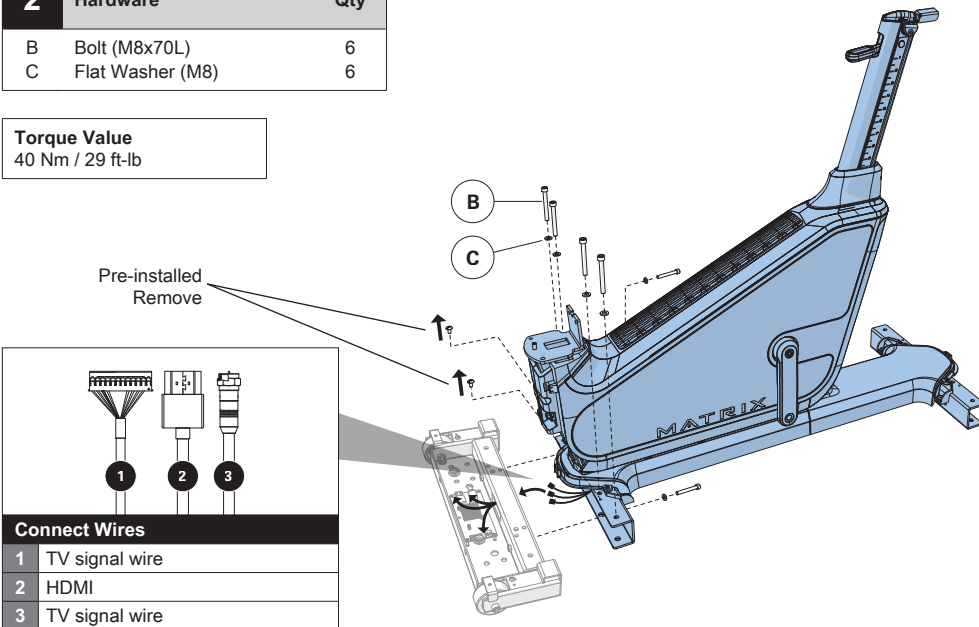

Connect Wires	
1	TV signal wire
2	HDMI
3	TV signal wire

4	Pre-installed	Qty
A	Screw (M5x12L)	4

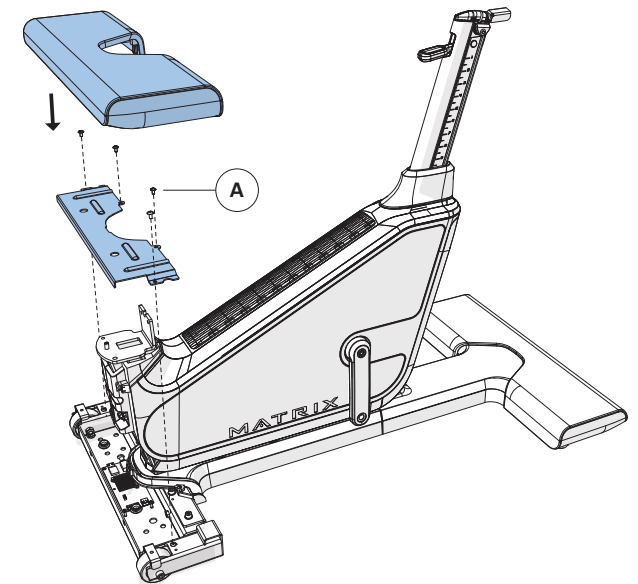

# ASSEMBLY

5	Hardware	Qty
D	Bolt (M8x20L)	2
E	Tooth Washer (M8)	2
F	Bolt (M8x95L-30L)	2

**Torque Value**  
40 Nm / 29 ft-lb

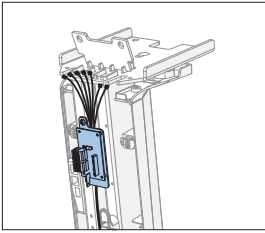

Remove bottom screw from C-Safe board, rotate to route cables behind it, then re-attach.

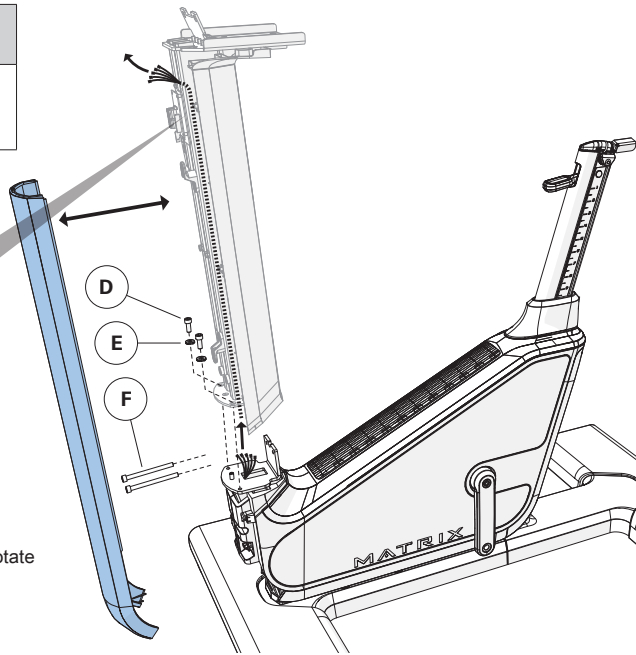

7	Hardware	Qty
J	Bolt (M8x20L)	6
C	Flat Washer (M8)	6

**Torque Value**  
35 Nm / 25 ft-lb

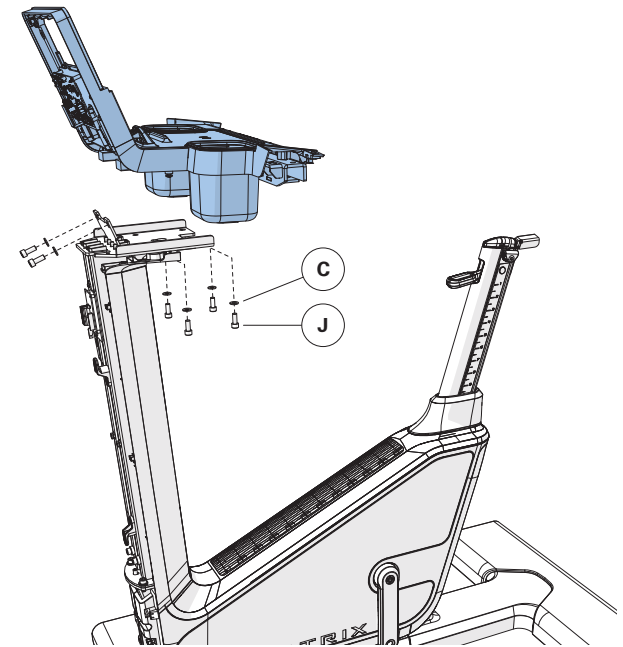

6	Pre-installed	Qty
G	Screw (M5x12L)	2
H	Screw (M5x25L)	2
I	Screw (M3x6L)	2

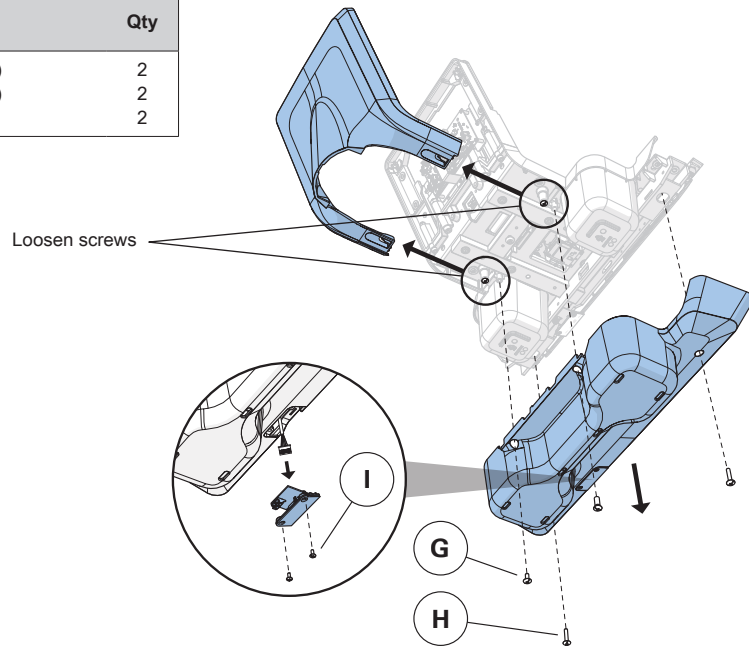

8	Hardware	Qty
J	Bolt (M8x20L)	4
C	Flat Washer (M8)	4

Pre-installed	Qty	
G	Screw (M5x12L)	2
H	Screw (M5x25L)	2
I	Screw (M3x6L)	2

**Torque Value (J)**  
35 Nm / 25 ft-lb

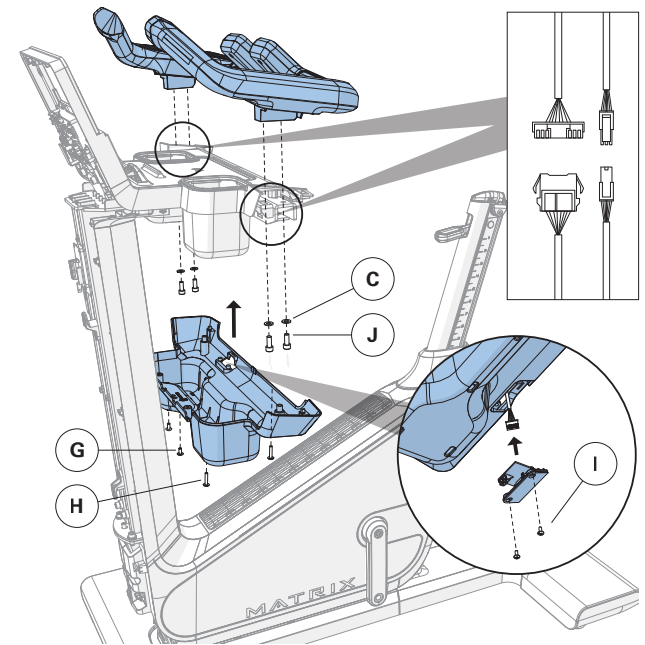

# ASSEMBLY

9	Hardware	Qty
K	Bolt (M8x25L)	4
C	Flat Washer (M8)	4

**Torque Value**  
25 Nm / 18 ft-lb

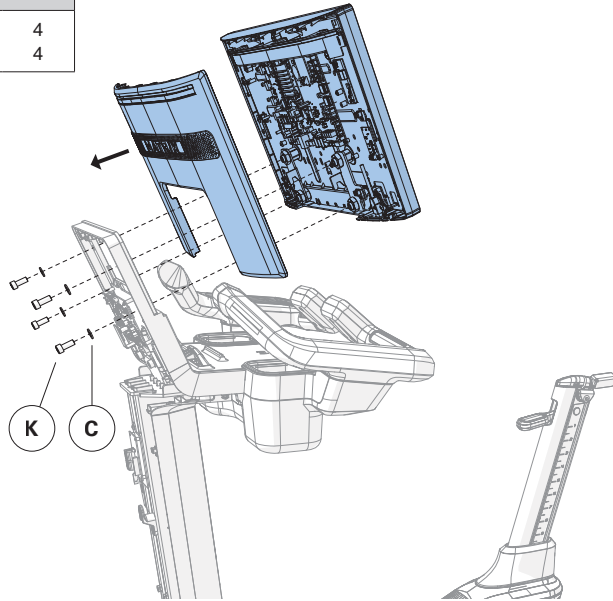

10	Route wires
1	HDMI
2	TV signal wire
3	Console ground wire
4	Ethernet
5	Digital com wire
6	LED extension wire (right)
7	PW connect wire
8	C-Safe wire
9	Power switch wire
10	Console LED display wire
11	USB
12	Headphone wire
13	RFID wire
14	Pulse connect wire

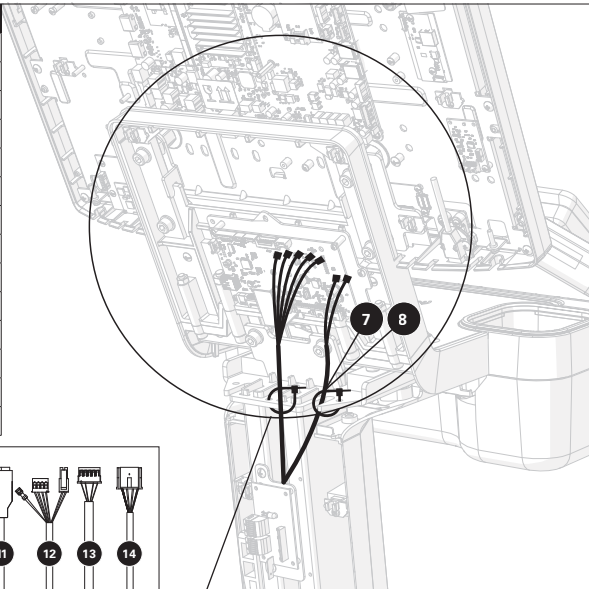
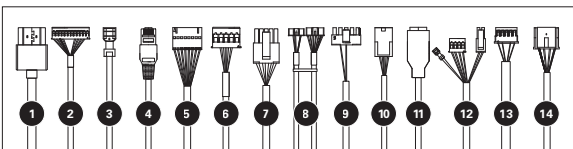

Secure with cable tie (2)

## 11

### Connect wires

- 1 HDMI \*
- 2 TV signal wire
- 3 Console ground wire
- 4 Ethernet
- 5 Digital com wire
- 6 LED extension wire (right)
- 7 PW connect wire
- 8 C-Safe wire
- 9 Power switch wire
- 10 Console LED display wire
- 11 USB
- 12 Headphone wire
- 13 RFID wire
- 14 Pulse connect wire

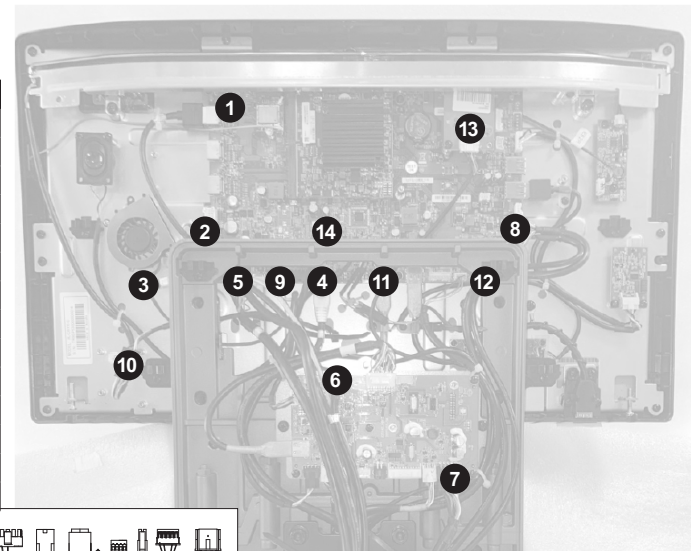
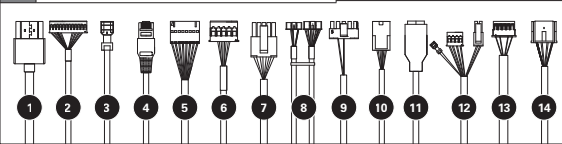

\* Connect to upper HDMI port

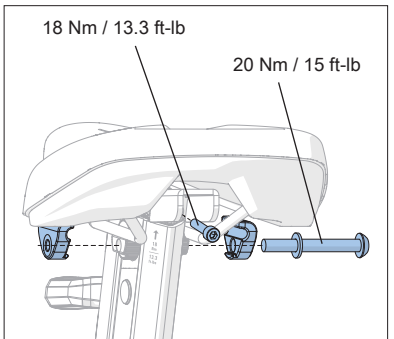
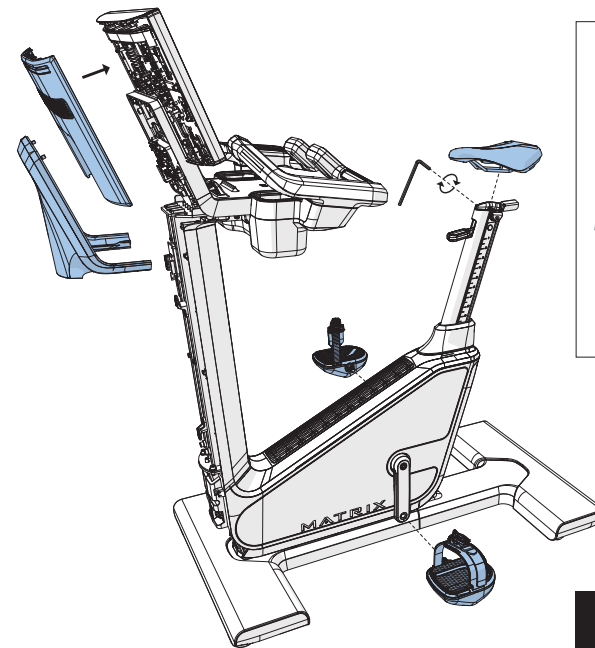

**ASSEMBLY COMPLETE**



## BEFORE YOU BEGIN

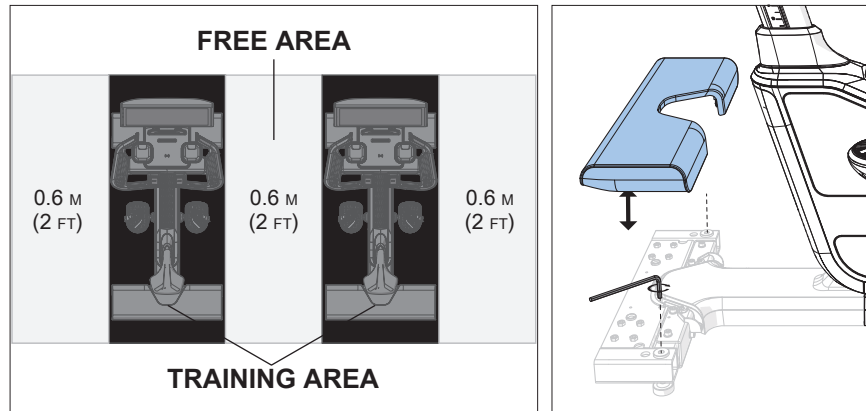

### LOCATION OF THE UNIT

Place the equipment on a level and stable surface away from direct sunlight. The intense UV light can cause discoloration on the plastics. Locate the equipment in an area with cool temperatures and low humidity. Please leave a free area behind the equipment that is at least 0.6 meters (24 inches). This area must be clear of any obstruction and provide the user a clear exit path from the equipment. Do not place the equipment in any area that will block any vent or air openings. The equipment should not be located in a garage, covered patio, near water or outdoors.

### LEVELING THE EQUIPMENT

The equipment should be level for optimum use. Once you have placed the equipment where you intend to use it, raise or lower one or both of the adjustable levelers located on the bottom of the frame. A carpenter's level is recommended.

### WARNING!

Our equipment is heavy, use care and additional help if necessary when moving. Failure to follow these instructions could result in injury.



### PROPER USAGE

To determine proper seat position, sit on the seat and position the ball of your foot on the center of the pedal. Your knee should bend slightly at the furthest pedal position. You should be able to pedal without locking your knees or shifting your weight from side to side. Adjust pedal straps to desired tightness.



## BEFORE YOU BEGIN

### POWER

If the equipment is powered by a power supply, the power must be plugged into the power jack, which is located in the front of the equipment near the stabilizer tube. Some equipment has a power switch, located next to the power jack. Make sure it is in the ON position. Unplug cord when not in use.

### WARNING!

Never operate equipment if it has a damaged cord or plug, if it is not working properly, if it has been damaged, or immersed in water. Contact Customer Tech Support for examination and repair.

### USING THE HEART RATE FUNCTION

The heart rate function on this product is not a medical device. While heart rate grips can provide a relative estimation of your actual heart rate, they should not be relied on when accurate readings are necessary. Some people, including those in a cardiac rehab program, may benefit from using an alternate heart rate monitoring system like a chest or wrist strap. Various factors, including movement of the user, may affect the accuracy of your heart rate reading. The heart rate reading is intended only as an exercise aid in determining heart rate trends in general. Please consult your physician.

Place the palm of your hands directly on the grip pulse handlebars. Both hands must grip the bars for your heart rate to register. It takes 5 consecutive heart beats (15-20 seconds) for your heart rate to register. When gripping the pulse handlebars, do not grip tightly. Holding the grips tightly may elevate your blood pressure. Keep a loose, cupping hold. You may experience an erratic readout if consistently holding the grip pulse handlebars. Make sure to clean the pulse sensors to ensure proper contact can be maintained.

### WARNING!

Heart rate monitoring systems may be inaccurate. Over exercising may result in serious injury or death. If you feel faint, stop exercising immediately.



## MAINTENANCE

1. Any and all part removal or replacement must be performed by a qualified service technician.
2. DO NOT use any equipment that is damaged and or has worn or broken parts. Use only replacement parts supplied by your country's local MATRIX dealer.
3. MAINTAIN LABELS AND NAMEPLATES: Do not remove labels for any reason. They contain important information. If unreadable or missing, contact your MATRIX dealer for a replacement.
4. MAINTAIN ALL EQUIPMENT: Preventative maintenance is the key to smooth operating equipment as well as keeping your liability to a minimum. Equipment needs to be inspected at regular intervals.
5. Ensure that any person(s) making adjustments or performing maintenance or repair of any kind is qualified to do so. MATRIX dealers will provide service and maintenance training at our corporate facility upon request.

## WARNING

To remove power from the unit, the power cord must be disconnected from the wall outlet.

MAINTENANCE SCHEDULE	
ACTION	FREQUENCY
Unplug the unit. Clean entire machine using water and a mild soap or other Matrix approved solution (cleaning agents should be alcohol and ammonia free).	DAILY
Inspect the power cord. If the power cord is damaged, contact Customer Tech Support.	DAILY
Make sure the power cord is not underneath the unit or in any other area where it can become pinched or cut during storage or use.	DAILY
Clean underneath the cycle, following these steps: <ul style="list-style-type: none"> <li>• Turn off the cycle.</li> <li>• Move the cycle to a remote location.</li> <li>• Wipe or vacuum any dust particles or other objects that may have accumulated underneath the cycle.</li> <li>• Return the cycle to its previous position.</li> </ul>	WEEKLY
Inspect all assembly bolts and pedals on the machine for proper tightness.	MONTHLY
Clean any debris off of the seat guide rail.	MONTHLY

PRODUCT SPECIFICATIONS	
Max User Weight	182 kg / 400 lbs
Product Weight	Narrow Stabilizer: 103.7 kg / 228.6 lbs Wide Stabilizer: 107.5 kg / 237.1 lbs
Shipping Weight	Narrow Stabilizer: 117.4 kg / 258.9 lbs Wide Stabilizer: 121.6 kg / 268.1 lbs
Overall Dimensions (L x W x H)*	129.1 x 65.6 x 155.1 cm / 50.8 x 25.9 x 61.1"

\* Ensure a minimum clearance width of 0.6 meters (24") for access to and passage around MATRIX equipment. Please note, 0.91 meters (36") is the ADA recommended clearance width for individuals in wheelchairs.

# ONYX

by MATRIX



UPRIGHT CYCLE

© 2025 Johnson Health Tech

Rev 1.1 A