

MATRIX

3x

3xe

5x





matrixfitness.com/manuals

ENG	To download the latest owner's manual, in the language of your choice, visit the website above. For further assistance, Matrix contact information is on the next page.
GER	Das neueste Benutzerhandbuch in der Sprache Ihrer Wahl können Sie auf der zuvor genannten Website herunterladen. Falls Sie weitere Hilfe benötigen, finden Sie die Matrix-Kontaktinformationen auf der nächsten Seite.
FRE	Pour télécharger la version la plus récente du guide d'utilisation dans la langue de votre choix, visitez le site ci-dessus. Si vous avez besoin d'aide, rendez-vous sur la page suivante pour obtenir les coordonnées de Matrix.
SPE	Para descargar el último manual de usuario en el idioma que prefiera, visite el sitio web anterior. Si necesita más ayuda, la información de contacto de Matrix se encuentra en la página siguiente.
DUT	Ga naar de bovenstaande website om de laatste gebruikershandleiding te downloaden in de taal van uw keuze. Voor extra hulp vindt u de Matrix-contactgegevens op de volgende pagina.
DAN	Du kan downloade den seneste brugsvejledning på dit foretrukne sprog fra webstedet ovenfor. Hvis du har brug for yderligere hjælp, henvises du til Matrix' kontaktoplysninger på næste side.
ITA	Per scaricare il più recente manuale del proprietario, nella lingua che preferisci, visita il sito Web indicato in precedenza. Per ulteriore assistenza, le informazioni di contatto per Matrix si trovano alla pagina successiva.
GRK	Για λήψη του πιο πρόσφατου εγχειριδίου χρήστη, στη γλώσσα της επιλογής σας, επισκεφθείτε την παραπάνω ιστοσελίδα. Για περαιτέρω βοήθεια, πληροφορίες επικοινωνίας με την Matrix παρέχονται στην επόμενη σελίδα.
POL	Aby pobrać najaktualniejszą wersję instrukcji obsługi w wybranym języku, należy odwiedzić powyższą stronę internetową. Jeśli potrzebna jest dalsza pomoc, można skorzystać z informacji kontaktowych Matrix podanych na kolejnej stronie.
PRB	Para baixar a versão mais recente do nosso manual em seu idioma, acesse o site acima. Para obter mais assistência, as informações de contato da Matrix estão na próxima página.
CHT	若要下載您所選語言版本的最新使用手冊，請造訪上述網站。 如需其他協助，請參閱下一頁的 Matrix 聯絡資訊。
JPN	ご希望の言語版の最新オーナーズマニュアルは、上記ウェブサイトからダウンロードしてください。 さらにサポートが必要な場合は、次ページに記載されているMatrixお問い合わせ窓口までご連絡ください。
KOR	선택한 언어로 최신 사용설명서를 다운로드하려면 위의 웹 사이트를 참조하십시오. 추가 지원이 필요한 경우 다음 페이지에 있는 Matrix 연락처 정보로 요청하십시오.
VTM	Để tải về sách hướng dẫn sử dụng mới nhất, bằng ngôn ngữ của bạn, hãy truy cập trang web bên trên. Để được trợ giúp thêm, thông tin liên lạc của Matrix có ở trang kế tiếp.
THI	ท่านสามารถดาวน์โหลดคู่มือผู้ใช้ล่าสุดในภาษาที่ต้องการได้จากเว็บไซต์ข้างต้น หากท่านต้องการ ความช่วยเหลืออื่นๆ โปรดติดต่อไปยังข้อมูลติดต่อ Matrix ที่ให้ไว้ในหน้าถัดไป
ARB	هالعال ببول عقوم ةدرايزب لصففت، اهراتخت يتلا لغلل اب، كلالل ليلد ثدحأ ليزنتل. ةلللال ءحفصلل فل Matrix ةكرشب ةصاخلل لاصللال تامولعلم ءجوت، ةءءاسمل نم ءلزل.



AUSTRALIA
Johnson Health Tech Australia
6B Hazelwood Drive
Morwell
VIC 3840 AUSTRALIA
Tel: +61 1300 760 601
au.matrixfitness.com

BRAZIL
Johnson Health Tech Brasil
Estrada Municipal, 200 - mód 14 e 15 - gleba 3
Chácara Alvorada
Indaiatuba, SP
CEP 13337-200 BRASIL
Tel: +55-19-2107-5300
br.matrixfitness.com

CANADA
Johnson Health Tech Canada
10401, Ray-Lawson Blvd.
Montreal, Quebec H1J 1M3
CANADA
Tel: 514-336-0006
www.matrixfitness.com

CHINA
Johnson Health Tech (Shanghai) Co., Ltd.
Rm 508-512
HuaWen Plaza 999 Zhongshan
(West) Road
Changning District
Shanghai, 200050 CHINA
Tel: +86-021-32503800
www.johnsonfitness.com.cn

FRANCE
Johnson Health Tech France
45, avenue Georges Politzer
Trappes
78190 FRANCE
Tel: +33 01 30 68 62 80
www.matrixfitness.fr

GERMANY / AUSTRIA
Johnson Health Tech. GmbH
Nikolaus-Otto-Str. 1
D-22946 Trittau GERMANY
Tel. +49 (0)4154-7952-0
www.matrixfitness.eu

GREECE
Johnson Health Tech Hellas SA
12 Vas. Konstantinou Avenue
116 35 Athens GREECE
Tel: +20 211 4112797
www.Johnson Health Tech.gr

HONG KONG
Johnson Health Tech (HK) Limited
Room 1501-1502, Aitken Vanson Centre,
61 Hoi Yuen Road, Kwun Tong
Kowloon
HONG KONG
Tel: +852-2302 0596
hk.matrixfitness.com

IBERIAN PENINSULA (SPAIN, PORTUGAL)
Johnson Health Tech Ibérica
Avenida de la Astronomía, 4 nave 9.2
San Fernando de Henares
28830 Madrid - ESPAÑA
Tel: +34-91 6293 688
www.matrixfitness.es

ITALY
Johnson Health Tech Italia Spa
Zona Ind.le Campolungo 11
63100 Ascoli Piceno (AP)
ITALY
Tel: +39 0736 22699
www.matrixfitness.it

JAPAN
Johnson Health Tech Japan
Yasuda Bldg. 2F,
3-3-8 Kaigan,
Minato-ku Tokyo 108-8435
JAPAN
Tel: +81-3-5419-3560
www.matrixfitness.jp

KOREA
Johnson Health Tech Co., Ltd. Korea Branch
203 ho, A-Block Richensia Young
San133-3 Wonhyoro 1-ga, Young San
Gu, 140-111 Seoul
SOUTH KOREA
Tel: +82-2-6731-0175
kr.matrixfitness.com

MALAYSIA
Johnson Fitness (Malaysia) Sdn. Bhd.
Lot 557D, Jalan Subang 3
Subang Jaya Industrial Estate
47610 Subang Jaya
Selangor MALAYSIA
Tel: +60-603-5632 8273
my.matrixfitness.com

NETHERLANDS (BELGIUM, DENMARK, LUXEMBOURG)
Matrix Fitness / Johnson Health Tech. Netherlands
Vleugelboot 14
3991 CL Houten
NETHERLANDS
Tel: +31 30 24 45 435
www.matrixfitness.nl

PHILIPPINES
Johnson Health Tech. Commercial Philippines Inc.
15th Floor, Citibank Center, 8741 Paseo de Roxas,
Makati City, Metro Manila, 1226 PHILIPPINES
Tel: +63-2-558-6590
world.matrixfitness.com

POLAND
Johnson Health Tech Poland
ul. Działkowa 62
02-234 Warszawa POLAND
Tel: +49 2234 9997-100
pl.matrixfitness.com

SWITZERLAND
Johnson Health Tech. (Schweiz) GmbH
Althardstrasse 185
CH-8105 Regensdorf SWITZERLAND
Tel. +41 (0)44-843 30 30
www.matrixfitness.ch

TAIWAN
Johnson Health Tech Taiwan
999, Sec 2, Dongda Rd., Daya Dist.,
Taichung City 428
TAIWAN (R.O.C)
Tel: +886-4-25667100
world.matrixfitness.com/zh

THAILAND
Johnson Health Tech Thailand
9th Floor, Unit 9B, Bangna Towers,
Tower A 2/3
Moo 14, Bangna-Trad Rd.
K.M. 6.5 Bangkaew, Pangplee
Samutprakan, 10540 THAILAND
Tel: +66-2751-9360
th.matrixfitness.com

UNITED ARAB EMIRATES
Johnson Health Tech. UAE
ICON Tower, Office #602
TECOM, Al Barsha
Dubai, United Arab Emirates
Tel: +971 4 4567939
world.matrixfitness.com/

UNITED KINGDOM
(ENGLAND, SCOTLAND, N. IRELAND, WALES)
Johnson Health Tech UK
Riverside park
Campbell Road
Stoke on Trent
ST4 4EY ENGLAND
Tel: +44-1782644900
www.matrixfitness.co.uk

UNITED STATES
Matrix Fitness / Johnson Health Tech NA
1600 Landmark Drive
Cottage Grove, WI 53527 USA
Toll Free: +1-866-693-4863
www.matrixfitness.com

VIETNAM
Johnson Health Tech (Vietnam) Co. Ltd.
Unit 2302, Lim Tower
9-11 Ton Duc Thang Street
Ben Nghe Ward, District 1
Ho Chi Minh City
VIETNAM
Tel: +84 909 977957
vn.matrixfitness.com

INTERNATIONAL (OTHER COUNTRIES)
Matrix Fitness International
999, Sec 2, Dongda Rd., Daya Dist.,
Taichung City 428
TAIWAN (R.O.C)
Tel: +886-4-25667100
world.matrixfitness.com



CONSOLE GUIDE

SERIAL NUMBER LOCATIONS

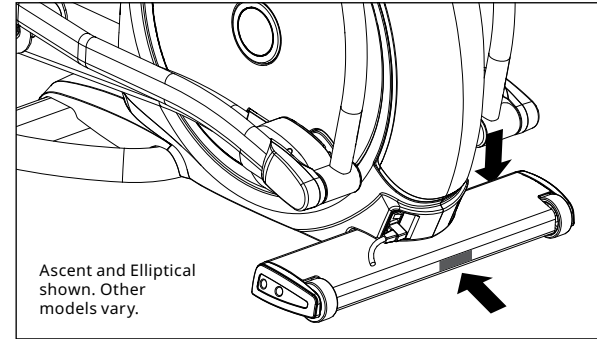
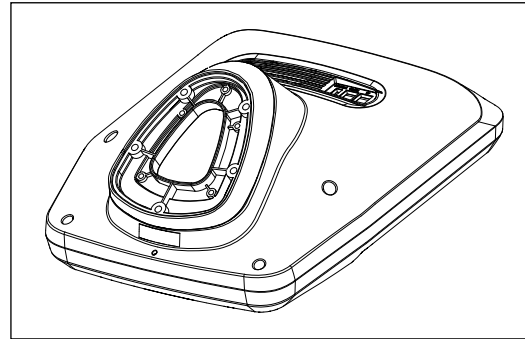

Before proceeding, find the serial numbers located on barcode stickers and enter them in the spaces provided below.

CONSOLE SERIAL NUMBER

FRAME SERIAL NUMBER

MODEL

<input type="checkbox"/> A3x	<input type="checkbox"/> A3xe	<input type="checkbox"/> A5x	MATRIX ASCENT TRAINER
<input type="checkbox"/> E3x	<input type="checkbox"/> E3xe	<input type="checkbox"/> E5x	MATRIX SUSPENSION ELLIPTICAL TRAINER
<input type="checkbox"/> ALB3x	<input type="checkbox"/> ALB3xe	<input type="checkbox"/> ALB5x	MATRIX ASCENT TRAINER LOWER BODY
<input type="checkbox"/> H3x	<input type="checkbox"/> H3xe	<input type="checkbox"/> H5x	MATRIX HYBRID CYCLE
<input type="checkbox"/> R3x	<input type="checkbox"/> R3xe	<input type="checkbox"/> R5x	MATRIX RECUMBENT CYCLE
<input type="checkbox"/> U3x	<input type="checkbox"/> U3xe	<input type="checkbox"/> U5x	MATRIX UPRIGHT CYCLE
<input type="checkbox"/> C3x	<input type="checkbox"/> C3xe	<input type="checkbox"/> C5x	MATRIX CLIMBMILL
<input type="checkbox"/> S3x	<input type="checkbox"/> S3xe	<input type="checkbox"/> S5x	MATRIX STEPPER

* Use the information above when calling for service.

A3X CONSOLE SHOWN

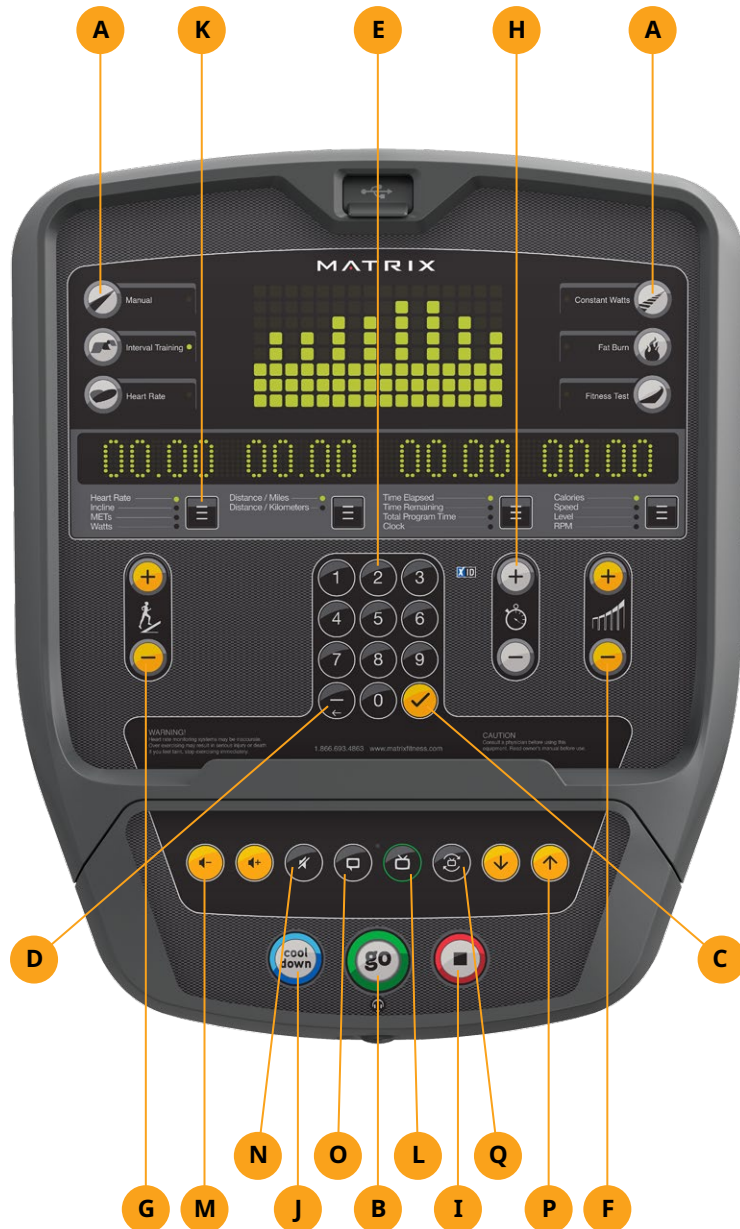

3X CONSOLE DESCRIPTION

The Matrix machine is inspected before it is packaged. It is shipped in two pieces: the base and the console. Carefully unpack the unit and dispose of the box material. Note: There is a thin protective sheet of clear plastic on the overlay of the console that should be removed before use.

- A) **WORKOUT KEYS:** Simple program view and selection buttons.
- B) **GO:** One Touch Start.
- C) **ENTER ✓:** Confirm each program setting.
- D) **BACK:** Go to previous program setting.
- E) **NUMBER KEYPAD:** Enter program settings.
- F) **UP/DOWN LEVEL:** Adjust resistance level.
- G) **UP/DOWN INCLINE (A3X ONLY):** Adjust incline level.
- H) **UP/DOWN TIME:** Adjust workout time.
- I) **STOP:** Ends workout and shows workout summary data.
- J) **COOL DOWN:** Puts the console into Cool Down mode.
- K) **TOGGLE DISPLAY:** Cycles between 3 or 4 rows of workout information displayed in LED window. The console will automatically cycle between the workout information if the Toggle Display button is pushed and held down for 3 seconds.

ENTERTAINMENT BUTTONS

- L) **TV POWER:** Turns connected TV on or off.
- M) **VOLUME UP/DOWN:** Adjusts the volume output through headphones.
- N) **MUTE:** Mutes sound.
- O) **CC:** Turns closed captioning on or off.
- P) **CHANNEL UP/DOWN:** Change channels on the integrated console TV.
- Q) **LAST CHANNEL:** Cycle between the current channel and the previous channel.
- E) **NUMBER KEYPAD:** Enter channel number. Press ✓ to confirm channel number.



3X



3XE CONSOLE SHOWN

3XE



3XE CONSOLE DESCRIPTION

The Matrix machine is inspected before it is packaged. It is shipped in two pieces: the base and the console. Carefully unpack the unit and dispose of the box material. Note: There is a thin protective sheet of clear plastic on the overlay of the console that should be removed before use.

The 3xe has a fully integrated touch screen display. All information required for workouts is explained on screen. Exploration of the interface is highly encouraged. The information explaining how to program for various workouts will give an explanation about the contents of each screen on the 3xe.

- A) **GO:** One Touch Start.
- B) **STOP** (displayed on-screen during workout): Ends workout and shows workout summary data.
- C) **COOL DOWN** (displayed on-screen during workout): Puts unit into Cool Down mode. Cool Down time is dependent on the workout.

3XE ENTERTAINMENT ZONE

- D) **VOLUME UP/DOWN:** Adjusts the volume output through headphones.
- E) **CHANNEL UP/DOWN:** Allows for channel selection on the integrated console TV.
- F) **HOME:** Will take the user back to the home screen.
- G) **LAST CHANNEL:** Allows the user to cycle between the current channel and the previous channel they were viewing.
- H) **CC/MUTE:** Mutes sound and turns closed captioning on or off.
- I) **DISPLAY MODE:** Allows user to cycle through display modes.
- J) **NUMBER KEYPAD:** Allows for easy number inputs.

A5X CONSOLE SHOWN



5X CONSOLE DESCRIPTION

The Matrix machine is inspected before it is packaged. It is shipped in two pieces: the base and the console. Carefully unpack the unit and dispose of the box material. Note: There is a thin protective sheet of clear plastic on the overlay of the console that should be removed before use.

- A) WORKOUT KEYS:** Simple program view and selection buttons.
- B) GO:** One Touch Start.
- C) ENTER:** To confirm each program setting.
- D) UP/DOWN INCLINE (A5X ONLY):** Easy information and incline selection.
- E) UP/DOWN LEVEL:** Easy information and level selection.
- F) UP/DOWN TIME:** Easy information and time adjustment.
- G) STOP:** Ends workout and shows workout summary data.
- H) TOGGLE DISPLAY:** Cycles between 2 or 4 rows of workout information displayed in LED window. The console will automatically cycle between the workout information if the Toggle Display button is pushed and held down for 3 seconds.
- I) NUMBER KEYPAD:** Workout data input for workout setup. Level adjustment during workout.
- J) COOL DOWN:** Puts the Ascent into Cool Down mode.
- K) LANGUAGE:** Select Language.
- L) FAN:** Allows for fan speed selection (fan has three operating speeds).
- M) RFID SENSOR:** Wireless login access location (optional add-on feature).*

5X ENTERTAINMENT ZONE

- N) HOME:** No function on this model.
- O) LAST CHANNEL:** Allows the user to cycle between the current channel and the previous channel they were viewing.
- P) CC:** Turns closed captioning on or off.
- Q) MUTE:** Mutes sound.
- R) VOLUME UP/DOWN:** Adjusts the volume output through headphones.
- S) NUMBER KEYPAD:** Allows for easy number inputs.
- T) CHANNEL UP/DOWN:** Allows for channel selection on the integrated console TV.
- U) TV POWER:** Turns external TV on or off.

* Supported standards with carrier frequency of 13.56 MHz include; ISO 14443 A, ISO 15693, ISO 14443 B, Sony Felica, Inside Contact-less (HID iClass), and LEGIC RF.





5X





3XE CONSOLE OPERATION

3XE

GETTING STARTED

- Touch the **USER** button to sign-in with your XID.
- Touch the **GUEST** button to workout anonymously.
- Touch the **REGISTER** button to create a new XID.
- For help or more information, touch .
- To change language, touch .

USER SIGN-IN

- 1) Enter your **XID** and touch .
- 2) Enter your **PASSCODE** and touch .

REGISTER A NEW USER

- 1) Don't have an xID account? Registration is easy.
- 2) Follow the on-screen prompts to create your free account.
- 3) Review your information and select the **I ACCEPT THE TERMS AND CONDITIONS** box to review the Terms and Conditions.
- 4) Touch  to complete registration. Your account is now active and you are signed-in.

LOGIN SCREEN

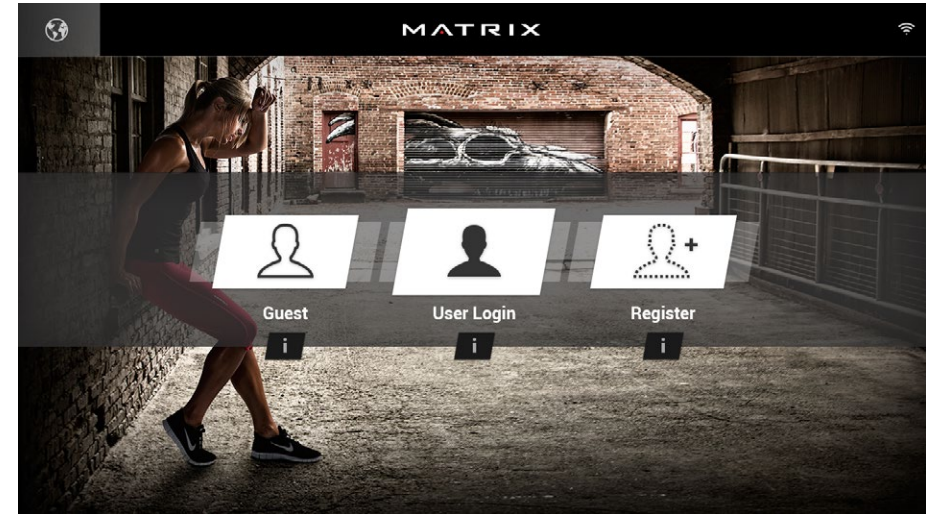

GO SCREEN

- Touch **GO** to begin working out immediately. Or...
- Touch the **WORKOUT CATEGORY** button of your choice to customize your workout.

PROGRAM SETUP

- 1) After selecting a **WORKOUT CATEGORY** button, select one of the **PROGRAMS** listed to the left.
For more information on a selected program, touch .
- 2) Use the **SLIDER CONTROLS** to adjust your program settings.
- 3) Press **GO** to begin your workout.

Note: Workouts and features vary based on model type, console configurations, software versions and options purchased.

GO SCREEN



PROGRAM SETUP

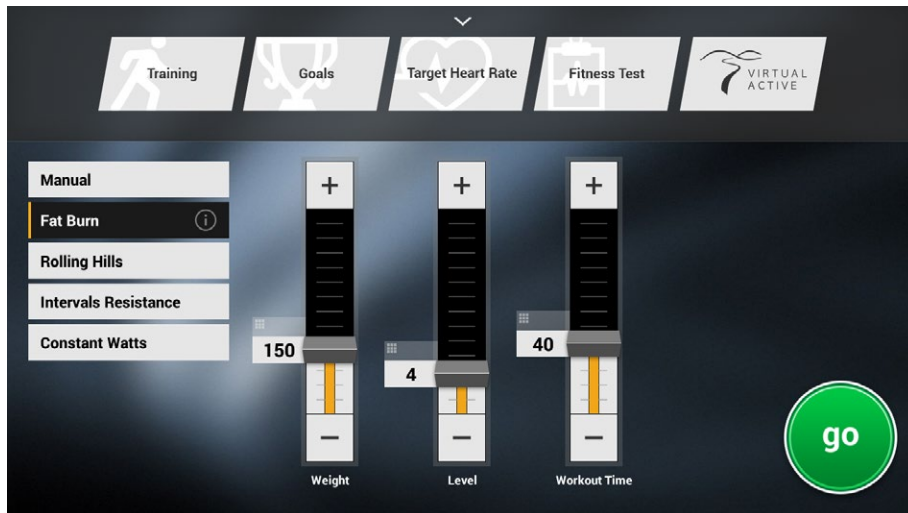

Note: Workouts and features vary based on model type, console configurations, software versions and options purchased.

HOME SCREEN



HOME SCREEN

- The **USERNAME** or **GUEST** is shown in the upper left corner.
- Touch **≡** to change **WORKOUT STATISTICS** displayed at the bottom of the screen.
- Touch **↑** to go back to the home screen whenever you're using an app.
- Touch **⚙** to adjust **VOLUME**, pair a **BLUETOOTH** device or to change **AUDIO SOURCE** (TV, My Media, Virtual Active, etc.).
- Touch **↓**/**↑** to increase or decrease the intensity level, speed or incline.
- Touch **⌘** to use the keypad to set intensity level, speed or incline. Press **⏹** to confirm change.
- Touch **↶** to change intensity level, speed or incline back to previous setting.
- Touch **⏸** to temporarily pause your workout and touch **▶** to resume. **NOTE:** After resuming, speed, incline and intensity levels will be reset.
- While paused, touch **■** to end workout.
- Touch **−**/**+** to increase or decrease the duration of your workout.
- Touch **⏴** to enter cool down mode. Cool down lasts for a few minutes while reducing the workout intensity, allowing your body to recover from your workout.
- Touch **🔒** to lock the screen in order to prevent accidental screen touches from being implemented. Touch it again to unlock the screen and allow screen touches.



3XE



3XE

APPS AND ENTERTAINMENT



SIMPLE

Workout stats are displayed in 3 customizable windows.



TRACK

Displays a 400 m (1/4 MILE) track. Split feature allows you to keep track of your fastest laps and improve your time.



VIRTUAL ACTIVE

Your workout info is displayed and Virtual Active courses are shown. With Virtual Active, escape the confines of an ordinary workout as you or walk or run through exotic destinations.



TARGET HEART RATE

Track your progress while working out to a Target Heart Rate program.



CONSTANT WATTS

Track your progress while working out to a Constant Watts program.



FITNESS TEST

Track your progress while working out to a Fitness Test program.



CHANGE WORKOUT

Select a different workout without stopping your current workout.



MY MEDIA

Connect and control audio and video files on-screen via USB port or Bluetooth.



TV

Watch live TV.



WEATHER

Get local weather info.



WEB BROWSER

Access the world wide web while you work out.



FACILITY CALENDAR

View Facility event schedule and other info.



YOUTUBE

Browse and watch YouTube videos while you work out.



FACEBOOK

Browse your Facebook page while you work out.



TWITTER

Access your Twitter feed while you work out.



NETFLIX

Browse and watch Netflix videos while you work out. Netflix account required to access content.



HULU PLUS

Browse and watch Hulu Plus videos while you work out. Hulu Plus account required to access content.



VEVO

Browse and watch Vevo videos while you work out. Vevo account required to access content.



VUDU

Browse and watch Vudu videos while you work out. Vudu account required to access content.



MYFITNESS PAL

Lose weight with MyFitnessPal, the fastest and easiest to use calorie counter.

Note: Workouts and features vary based on model type, console configurations, software versions and options purchased.

**NOTE:**

This equipment has been tested and found to comply with the limits for a Class B digital device, pursuant to part 15 of the FCC rules. These limits are designed to provide reasonable protection against harmful interference in a residential installation. This equipment generates, uses and can radiate radio frequency energy and, if not installed and used in accordance with the instructions, may cause harmful interference to radio communications. However, there is no guarantee that interference will not occur in a particular installation. If this equipment does cause harmful interference to radio or television reception, which can be determined by turning the equipment off and on, the user is encouraged to try to correct the interference by one or more of the following measures:

- Reorient or relocate the receiving antenna.
- Increase the separation between the equipment and receiver.
- Connect the equipment into an outlet on a circuit different from that to which the receiver is connected.
- Consult the dealer or an experienced radio/TV technician for help.

Any changes or modifications not expressly approved by the party responsible for compliance could void the user's authority to operate this equipment.

FCC RF Radiation Exposure Statement:

1. This Transmitter must not be co-located or operating in conjunction with any other antenna or transmitter.
2. This equipment complies with FCC RF radiation exposure limits set forth for an uncontrolled environment. This equipment should be installed and operated with a minimum distance of 20 centimeters between the radiator and your body

MATRIX