

# MATRIX

5x

7xe

7xi







# CONSOLE GUIDE

## SERIAL NUMBER LOCATIONS

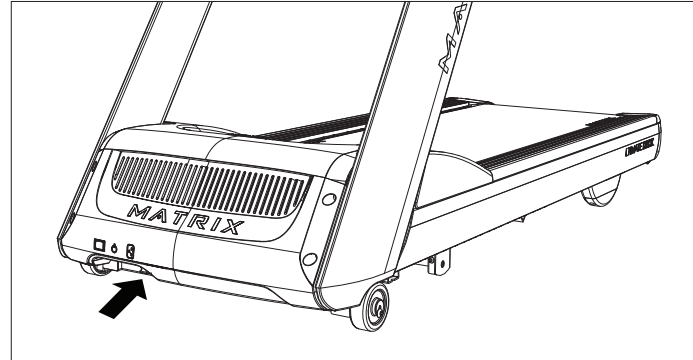
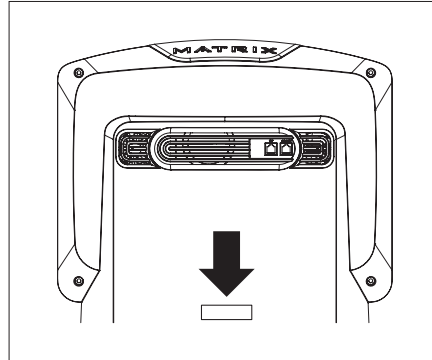

Before proceeding, find the serial numbers located on barcode stickers and enter them in the spaces provided below.

### CONSOLE SERIAL NUMBER

### FRAME SERIAL NUMBER

### MODEL

T5x     T5xGT     T7xe     T7xi    **MATRIX TREADMILL**

\* Use the information above when calling for service.



5X

ENGLISH



## T5X CONSOLE DESCRIPTION

The Matrix machine is inspected before it is packaged. It is shipped in two pieces: the base and the console. Carefully unpack the unit and dispose of the box material. Note: There is a thin protective sheet of clear plastic on the overlay of the console that should be removed before use.

- A) **WORKOUT KEYS:** Simple program view and selection buttons. Press Fitness Test button to cycle through available tests.
- B) **GO:** One Touch Start.
- C) **ENTER:** To confirm each program setting.
- D) **UP/DOWN INCLINE:** Adjust incline and make program selections.
- E) **UP/DOWN SPEED:** Adjust speed and make program selections.
- F) **UP/DOWN TIME:** Adjust time and make program selections.
- G) **EMERGENCY STOP / IMMOBILIZATION:** To stop all functions and immobilize the unit. The emergency stop on this treadmill must be returned to its original position in order to allow normal operation of the unit.
- H) **STOP:** Ends workout and shows workout summary data.
- I) **PAUSE:** Pauses workout. Pause duration can be set in manager or engineering mode.
- J) **NUMBER KEYPAD:** Workout data input for workout setup. Speed adjustment during workout.
- K) **COOL DOWN:** Puts treadmill into Cool Down mode. Cool Down time is dependent on the length of the workout. Workouts 19 minutes and shorter will have a cool down length of 2 minutes. Workouts 20 minutes and longer will have a cool down length of 5 minutes.
- L) **FAN:** Allows for fan speed selection (fan has three operating speeds.)
- M) **TOGGLE DISPLAY:** Cycles between 4 rows of workout information displayed in LED window. The console will automatically cycle between the workout information if the Toggle Display button is pushed and held down for 3 seconds.
- N) **LANGUAGE:** Select Language.
- O) **RFID SENSOR:** Wireless login access location (optional add-on feature).\*

\* Supported standards with carrier frequency of 13.56 MHz include; ISO 14443 A, ISO 15693, ISO 14443 B, Sony Felica, Inside Contact-less (HID iClass), and LEGIC RF.



### T5X GT CONSOLE DESCRIPTION

The Matrix Machine is inspected before it is packaged. It is shipped in two pieces: the base and the console. Carefully unpack the unit and dispose of the box material. Note: There is a thin protective sheet of clear plastic on the overlay of the console that should be removed before use.

The T5xGT treadmill is specifically designed for Group Training settings, with one touch speed and incline controls for members to follow coaching and make easy changes on the fly.

**A) INTENSITY BUTTONS:**

Pre-workout - Press to customize your low/medium/high intensity presets.  
During workout - Press to automatically adjust speed to your presets.  
Note: Default speed/incline presets will be used if not customized pre-workout.

**B) INCLINE QUICK KEYS:** Adjust incline during workout.

**C) SPEED QUICK KEYS:** Adjust speed during workout.

**D) FAN:** Allows for fan speed selection (fan has three operating speeds.)

**E) PAUSE:** Pauses workout. Pause duration can be set in manager or engineering mode.

**F) STOP:** Ends workout and shows workout summary data.

**G) GO:** One Touch Start

NOTE: To access manager mode on the T5xGT console, press and hold the '1' buttons for speed and incline for 4 seconds. Navigate the menus using handle bar toggles.





7XI

ENGLISH



## T7XI CONSOLE DESCRIPTION

The Matrix machine is inspected before it is packaged. It is shipped in two pieces: the base and the console. Carefully unpack the unit and dispose of the box material. Note: There is a thin protective sheet of clear plastic on the overlay of the console that should be removed before use.

The T7xi has a fully integrated touch screen display. All information required for workouts is explained on-screen. Exploration of the interface is highly encouraged. The information explaining how to program for various workouts will give an explanation about the contents of each screen on the T7xi.

- A) **GO:** One Touch Start.
- B) **STOP:** Ends workout and shows workout summary data.
- C) **INCLINE TOGGLES:** Adjust incline during workout.
- D) **SPEED TOGGLES:** Adjust speed during workout.
- E) **COOL DOWN:** Puts treadmill into Cool Down mode. Cool Down time is dependent on the length of the workout. Workouts 19 minutes and shorter will have a cool down length of 2 minutes. Workouts 20 minutes and longer will have a cool down length of 5 minutes.
- F) **EMERGENCY STOP / IMMOBILIZATION:** To stop all functions and immobilize the unit. The emergency stop on this treadmill must be returned to its original position in order to allow normal operation of the unit.

## T7XI ENTERTAINMENT ZONE

- G) **VOLUME UP/DOWN:** Adjusts the volume output through headphones.
- H) **CHANNEL UP/DOWN:** Allows for channel selection on the integrated console TV.
- I) **HOME:** Will take the user back to the home screen.
- J) **LAST CHANNEL:** Allows the user to cycle between the current channel and the previous channel they were viewing.
- K) **CC/MUTE:** Mutes sound and turns closed captioning on or off.
- L) **DISPLAY MODE:** Allows user to cycle through display modes.
- M) **NUMBER KEYPAD:** Allows for easy number inputs.
- N) **RFID SENSOR:** Wireless login access location (optional add-on feature).



7XE

ENGLISH

## T7XE CONSOLE DESCRIPTION

The Matrix machine is inspected before it is packaged. It is shipped in two pieces: the base and the console. Carefully unpack the unit and dispose of the box material. Note: There is a thin protective sheet of clear plastic on the overlay of the console that should be removed before use.

The T7xe has a fully integrated touch screen display. All information required for workouts is explained on-screen. Exploration of the interface is highly encouraged. The information explaining how to program for various workouts will give an explanation about the contents of each screen on the T7xe.

- A) **GO:** One Touch Start.
- B) **STOP:** Ends workout and shows workout summary data.
- C) **INCLINE TOGGLES:** Adjust incline during workout.
- D) **SPEED TOGGLES:** Adjust speed during workout.
- E) **COOL DOWN:** Puts treadmill into Cool Down mode. Cool Down time is dependent on the length of the workout. Workouts 19 minutes and shorter will have a cool down length of 2 minutes. Workouts 20 minutes and longer will have a cool down length of 5 minutes.
- F) **EMERGENCY STOP / IMMOBILIZATION:** To stop all functions and immobilize the unit. The emergency stop on this treadmill must be returned to its original position in order to allow normal operation of the unit.

## T7XE ENTERTAINMENT ZONE

- G) **VOLUME UP/DOWN:** Adjusts the volume output through headphones.
- H) **CHANNEL UP/DOWN:** Allows for channel selection on the integrated console TV.
- I) **HOME:** Will take the user back to the home screen.
- J) **LAST CHANNEL:** Allows the user to cycle between the current channel and the previous channel they were viewing.
- K) **CC/MUTE:** Mutes sound and turns closed captioning on or off.
- L) **DISPLAY MODE:** Allows user to cycle through display modes.
- M) **NUMBER KEYPAD:** Allows for easy number inputs.
- N) **RFID SENSOR:** Wireless login access location (optional add-on feature).







## 7XE / 7XI CONSOLE OPERATION



7XE  
7XI

ENGLISH

### GETTING STARTED

- Touch the **USER** button to sign-in with your XID.
- Touch the **GUEST** button to workout anonymously.
- Touch the **REGISTER** button to create a new XID.
- For help or more information, touch .
- To change language, touch .

### USER SIGN-IN

- 1) Enter your **XID** and touch .
- 2) Enter your **PASSCODE** and touch .



Consoles equipped with RFID will have this symbol in the lower-right corner of the display. To log in, touch your RFID tag to the symbol  located on the bottom right of the console. \*

### REGISTER A NEW USER

- 1) Don't have an xID account? Registration is easy.
- 2) Follow the on-screen prompts to create your free account.
- 3) Review your information and select the **I ACCEPT THE TERMS AND CONDITIONS** box to review the Terms and Conditions.
- 4) Touch  to complete registration. Your account is now active and you are signed-in.

### LOGIN SCREEN

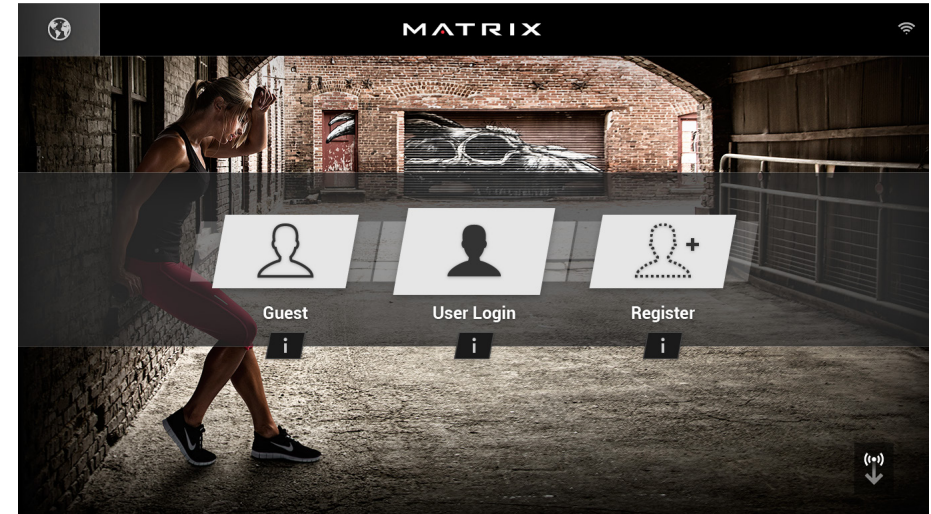

### GO SCREEN

- Touch **GO** to begin working out immediately. Or...
- Touch the **WORKOUT CATEGORY** button of your choice to customize your workout.

### PROGRAM SETUP

- 1) After selecting a **WORKOUT CATEGORY** button, select one of the **PROGRAMS** listed to the left.  
For more information on a selected program, touch .
- 2) Use the **SLIDER CONTROLS** to adjust your program settings.
- 3) Press **GO** to begin your workout.

**Note:** Workouts and features vary based on model type, console configurations, software versions and options purchased.

\* Supported standards with carrier frequency of 13.56 MHz include; ISO 14443 A, ISO 15693, ISO 14443 B, Sony Felica, Inside Contact-less (HID iClass), and LEGIC RF.

## GO SCREEN

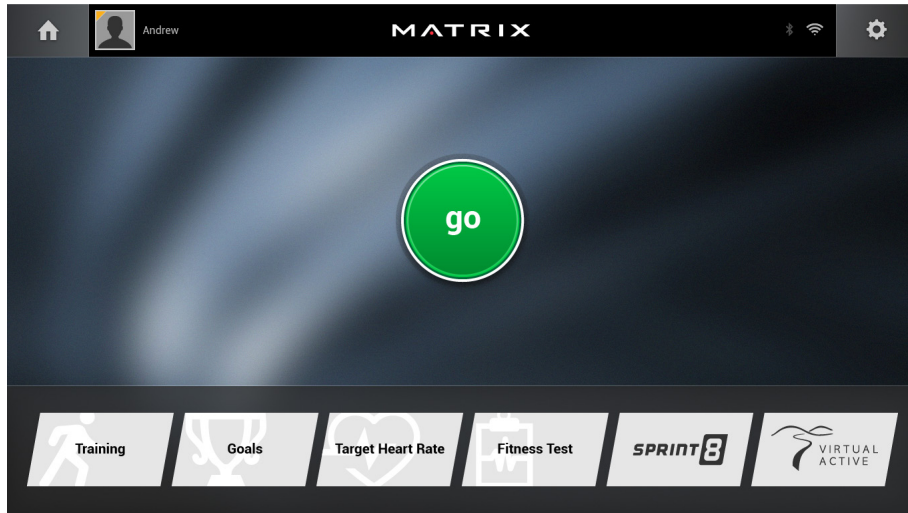

## PROGRAM SETUP

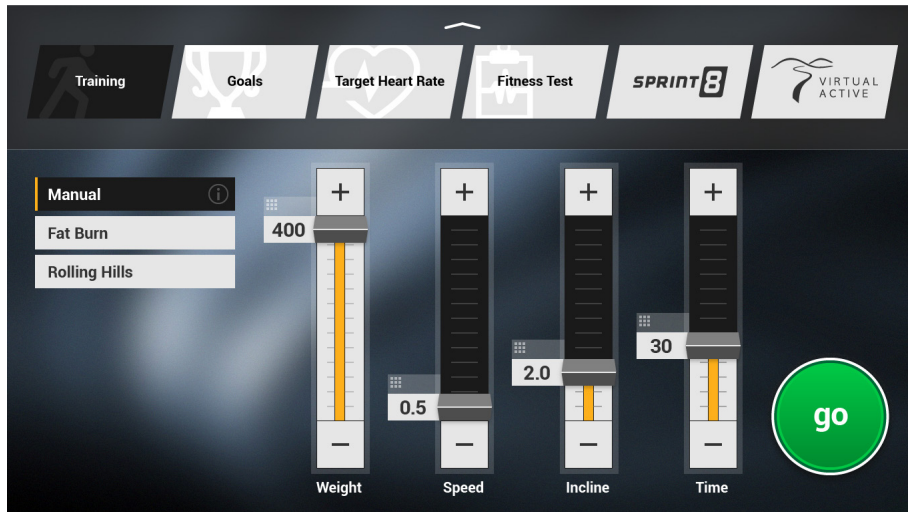

**Note:** Workouts and features vary based on model type, console configurations, software versions and options purchased.

## HOME SCREEN



## HOME SCREEN

- The **USERNAME** or **GUEST** is shown in the upper left corner.
- Touch to change **WORKOUT STATISTICS** displayed at the bottom of the screen.
- Touch to go back to the home screen whenever you're using an app.
- Touch to adjust **VOLUME**, pair a **BLUETOOTH** device or to change **AUDIO SOURCE** (TV, My Media, Virtual Active, etc.).
- Touch to increase or decrease the intensity level, speed or incline.
- Touch to use the keypad to set intensity level, speed or incline. Press to confirm change.
- Touch to change intensity level, speed or incline back to previous setting.
- Touch to temporarily pause your workout and touch to resume. **NOTE:** After resuming, speed, incline and intensity levels will be reset.
- While paused, touch to end workout.
- Touch to increase or decrease the duration of your workout.
- Touch to enter cool down mode. Cool down lasts for a few minutes while reducing the workout intensity, allowing your body to recover from your workout.
- Touch to lock the screen in order to prevent accidental screen touches from being implemented. Touch it again to unlock the screen and allow screen touches.
- Touch to turn the fan on. There are three fan speeds (low, medium, high).



7XE  
7XI

ENGLISH



7XE  
7XI

ENGLISH

## APPS AND ENTERTAINMENT



### **SIMPLE**

Workout stats are displayed in 3 customizable windows.



### **TRACK**

Displays a 400 M (1/4 MILE) track. Split feature allows you to keep track of your fastest laps and improve your time.



### **VIRTUAL ACTIVE**

Your workout info is displayed and Virtual Active courses are shown. With Virtual Active, escape the confines of an ordinary workout as you or walk or run through exotic destinations.



### **TARGET HEART RATE**

Track your progress while working out to a Target Heart Rate program.



### **FITNESS TEST**

Track your progress while working out to a Fitness Test program.



### **SPRINT 8**

Track your progress while working out to a Sprint 8 program.



### **CHANGE WORKOUT**

Select a different workout without stopping your current workout.



### **MY MEDIA**

Connect and control audio and video files on-screen via USB port or Bluetooth.



### **TV**

Watch live TV.



### **WEATHER**

Get local weather info.



### **WEB BROWSER**

Access the world wide web while you work out.



### **FACILITY CALENDAR**

View Facility event schedule and other info.



### **YOUTUBE**

Browse and watch YouTube videos while you work out.



### **FACEBOOK**

Browse your Facebook page while you work out.



### **TWITTER**

Access your Twitter feed while you work out.



### **NETFLIX**

Browse and watch Netflix videos while you work out.  
Netflix account required to access content.



### **HULU**

Browse and watch Hulu videos while you work out.  
Hulu account required to access content.



### **MYFITNESS PAL**

Lose weight with MyFitnessPal, the fastest and easiest to use calorie counter.

**Note:** Workouts and features vary based on model type, console configurations, software versions and options purchased.

**NOTE:**

This equipment has been tested and found to comply with the limits for a Class B digital device, pursuant to part 15 of the FCC rules. These limits are designed to provide reasonable protection against harmful interference in a residential installation. This equipment generates, uses and can radiate radio frequency energy and, if not installed and used in accordance with the instructions, may cause harmful interference to radio communications. However, there is no guarantee that interference will not occur in a particular installation. If this equipment does cause harmful interference to radio or television reception, which can be determined by turning the equipment off and on, the user is encouraged to try to correct the interference by one or more of the following measures:

- Reorient or relocate the receiving antenna.
- Increase the separation between the equipment and receiver.
- Connect the equipment into an outlet on a circuit different from that to which the receiver is connected.
- Consult the dealer or an experienced radio/TV technician for help.

Any changes or modifications not expressly approved by the party responsible for compliance could void the user's authority to operate this equipment.

FCC RF Radiation Exposure Statement:

1. This Transmitter must not be co-located or operating in conjunction with any other antenna or transmitter.
2. This equipment complies with FCC RF radiation exposure limits set forth for an uncontrolled environment. This equipment should be installed and operated with a minimum distance of 20 centimeters between the radiator and your body

# MATRIX