

MATRIX

VERSA SERIES

WEIGHT STACK

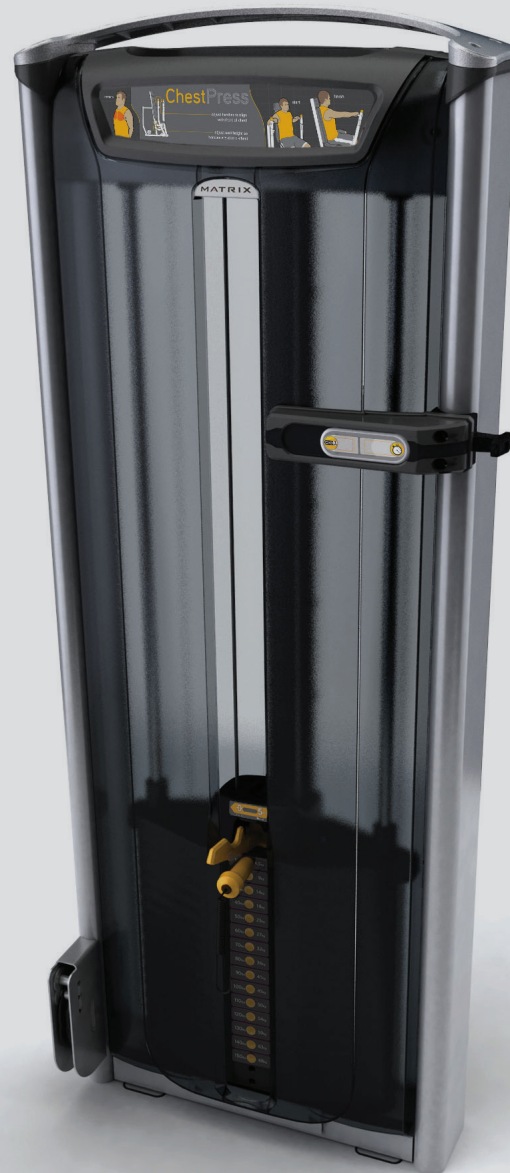



CONFIGURATIONS

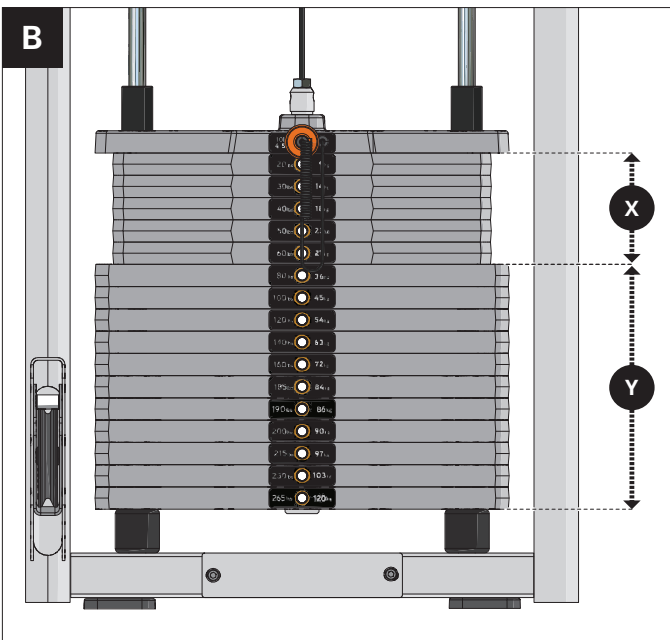
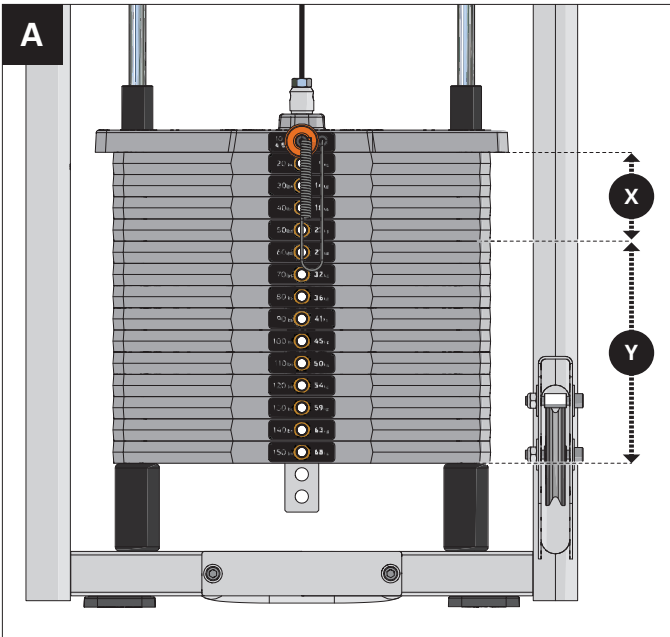

STACK DECALS

D1	D2	D3	D4	D5	D6	D7	D8
lbs 10 kg 4.5	lbs 10 kg 4.5					15	15
lbs 20	lbs 20	lbs 40		lbs 20	lbs 20	25	25
lbs 30	lbs 30	lbs 65		lbs 30	lbs 30	35	35
lbs 40	lbs 40	lbs 90		lbs 40	lbs 40	45	45
lbs 50	lbs 50	lbs 115		lbs 50	lbs 50	55	55
lbs 60	lbs 65	lbs 140	lbs 15	lbs 60	lbs 65	65	65
lbs 70	lbs 80	lbs 165	lbs 30	lbs 70	lbs 80	75	75
lbs 80	lbs 95	lbs 190	lbs 45	lbs 80	lbs 95	85	85
lbs 90	lbs 110	lbs 215	lbs 60	lbs 90	lbs 110	95	95
lbs 100	lbs 125	lbs 240	lbs 75	lbs 100	lbs 125	105	105
lbs 110	lbs 140	lbs 265	lbs 90	lbs 110	lbs 140	115	115
lbs 120	lbs 155	lbs 290	lbs 105	lbs 120	lbs 155	125	125
lbs 130	lbs 170	lbs 315	lbs 120	lbs 130	lbs 170	135	135
lbs 140	lbs 185	lbs 340	lbs 135	lbs 140	lbs 185	145	145
lbs 150	lbs 200	lbs 365	lbs 150	lbs 150	lbs 200	155	155
lbs 160	lbs 215	lbs 390		lbs 160	lbs 215	165	165
	lbs 230	lbs 415			lbs 230	175	185
						185	205
						195	225
						205	245
							265
							285
							305

WEIGHT PLATES

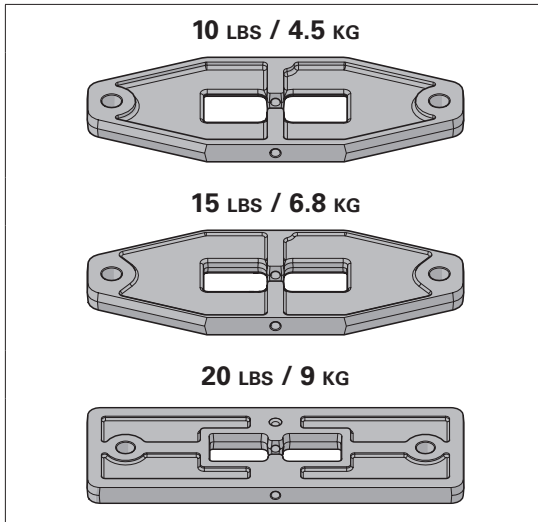

BUMPER

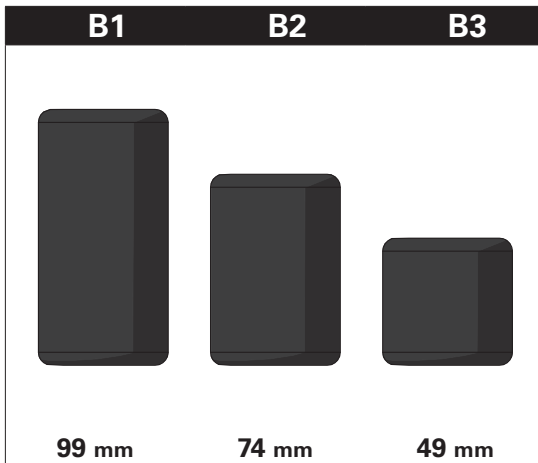

CONFIGURATIONS

MODEL	CONFIGURATION	BUMPER	DECAL	WEIGHT PLATES	TOTAL LABELED WEIGHT		
					LBS	KG	
VS-S13	Chest Press	Standard Stack - A	B2	D1	X: 15 x 10 lbs + headplate	160	72
		Heavy Stack - A	B3	D2	X: 4 x 10 lbs + headplate / Y: 12 x 15 lbs	230	104
VS-S34	Seated Row	Standard Stack - A	B2	D1	X: 15 x 10 lbs + headplate	160	72
		Heavy Stack - A	B3	D2	X: 4 x 10 lbs + headplate / Y: 12 x 15 lbs	230	104
VS-S72	Seated Leg Curl	Standard Stack - A	B1	D1	X: 14 x 10 lbs + headplate	150	68
		Heavy Stack - A	B1	D2	X: 4 x 10 lbs + headplate / Y: 10 x 15 lbs	200	90
VS-S71	Leg Extension	Standard Stack - A	B2	D1	X: 15 x 10 lbs + headplate	160	72
		Heavy Stack - A	B3	D2	X: 4 x 10 lbs + headplate / Y: 12 x 15 lbs	230	104
VS-S23	Shoulder Press	Standard Stack - A	B2	D1	X: 15 x 10 lbs + headplate	160	72
		Heavy Stack - A	B3	D2	X: 4 x 10 lbs + headplate / Y: 12 x 15 lbs	230	104
VS-S70	Leg Press	Heavy Stack - A	B3	D3	X: 16 x 20 lbs + headplate	415	188
VS-S33	Lat Pulldown	Standard Stack - A	B2	D1	X: 15 x 15 lbs + headplate	160	72
		Heavy Stack - B	B3	D2	X: 4 x 15 lbs + headplate / Y: 12 x 20 lbs	230	104
VS-S42	Seated Triceps Press	Standard Stack - A	B2	D1	X: 15 x 10 lbs + headplate	160	72
		Heavy Stack - A	B3	D2	X: 4 x 10 lbs + headplate / Y: 12 x 15 lbs	230	104
VS-S40	Bicep Curl	Standard Stack - A	B1	D1	X: 14 x 10 lbs + headplate	150	68
		Heavy Stack - A	B1	D2	X: 4 x 10 lbs + headplate / Y: 10 x 15 lbs	200	90
VS-S74	Hip Adductor / Abductor	Standard Stack - A	B2	D1	X: 15 x 10 lbs + headplate	160	72
		Heavy Stack - A	B3	D2	X: 4 x 10 lbs + headplate / Y: 12 x 15 lbs	230	104
VS-S22	Pec Fly / Rear Delt	Standard Stack - A	B1	D1	X: 14 x 10 lbs + headplate	150	68
		Heavy Stack - A	B1	D2	X: 4 x 10 lbs + headplate / Y: 10 x 15 lbs	200	90
VS-S53	Abdominal	Standard Stack - A	B2	D1	X: 15 x 10 lbs + headplate	160	72
		Heavy Stack - A	B3	D2	X: 4 x 10 lbs + headplate / Y: 12 x 15 lbs	230	104
VS-S52	Back Extension	Standard Stack - A	B2	D1	X: 15 x 10 lbs + headplate	160	72
		Heavy Stack - A	B3	D2	X: 4 x 10 lbs + headplate / Y: 12 x 15 lbs	230	104
VS-S78	Glute	Standard Stack - A	B1	D1	X: 14 x 10 lbs + headplate	150	68
VS-S131	Multi Press	Standard Stack - A	B2	D1	X: 15 x 10 lbs + headplate	160	72
		Heavy Stack - A	B3	D2	X: 4 x 10 lbs + headplate / Y: 12 x 15 lbs	230	104
VS-S331	Lat Pulldown / Seated Row	Standard Stack - A	B2	D5	X: 15 x 10 lbs + headplate	160	72
		Heavy Stack - A	B3	D6	X: 4 x 10 lbs + headplate / Y: 12 x 15 lbs	230	104
VS-S401	Bicep / Triceps	Standard Stack - A	B1	D1	X: 14 x 10 lbs + headplate	150	68
		Heavy Stack - A	B1	D2	X: 4 x 10 lbs + headplate / Y: 10 x 15 lbs	200	90
VS-S531	Ab/Back Extension	Standard Stack - A	B2	D1	X: 15 x 10 lbs + headplate	160	72
		Heavy Stack - A	B3	D2	X: 4 x 10 lbs + headplate / Y: 12 x 15 lbs	230	104
VS-S601	Chin / Dip Assist	Heavy Stack - A	B1	D4	X: 14 x 15 lbs + head plate	150	68
VS-S711	Leg Extension / Seated Leg Curl	Standard Stack - A	B2	D1	X: 15 x 10 lbs + headplate	160	72
		Heavy Stack - A	B3	D2	X: 4 x 10 lbs + headplate / Y: 12 x 15 lbs	230	104
MD-S711	Med Leg Ext / Curl	Standard Stack - A	B2	D7	X: 19 x 10 lbs + headplate	205	93
MD-S70	Med Leg Press	Standard Stack - A	B3	D8	X: 15 x 10 lbs + headplate / Y: 7 x 20 lbs	305	138.3



ASSEMBLY

UNPACKING

Thank you for purchasing a MATRIX Fitness product. It is inspected before it is packaged. It is shipped in multiple pieces to facilitate the compact packaging of the machine. Prior to assembly, confirm all the components by matching them with the exploded diagrams. Carefully unpack the unit from this box and dispose of the packing materials in accordance with your local laws.

CAUTION

To avoid injury to yourself and prevent damage to the frame components, be sure to have proper assistance removing the frame pieces from this box. Please be sure to install the equipment on a stable base, and properly level the machine. Ensure a minimum clearance width of 0.6 meters (24") for access to and passage around MATRIX strength equipment. Please note, 0.91 meters (36") is the ADA recommended clearance width for individuals in wheelchairs.

1

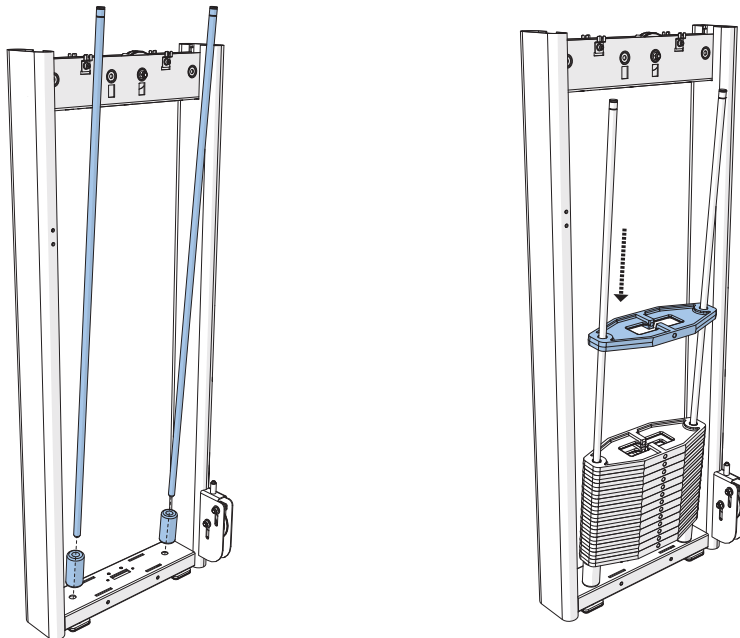

2

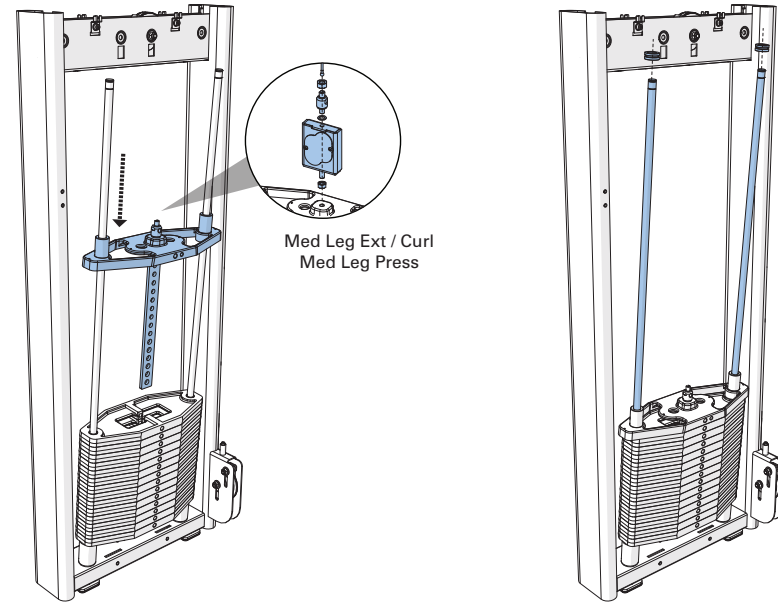

3

MACHINE	STOP COLLAR DEPTH (Z)
Chest Press	260 mm / 10.2"
Shoulder Press	90 mm / 3.5"
Leg Extension	No Collars
Seated Leg Curl	No Collars
Leg Press	10 mm / 0.4"
Lat Pulldown	No Collars
Triceps Press	288 mm (11.3")
Seated Row	No Collars
Bicep Curl	No Collars
Hip Add/Abduction	No Collars
Pec Fly/Rear Delt	No Collars
Abdominal	460 mm / 18.3"
Back Extension	465 mm / 18.3"
Glute	No Collars
Multi Press	No Collars
Lat Pulldown/ Seated Row	No Collars
Bicep/Triceps	No Collars
Ab/Back Extension	No Collars
Chin / Dip Assist	No Collars
Leg Extension/ Seated Leg Curl	No Collars
Med Leg Ext / Curl	No Collars
Med Leg Press	No Collars

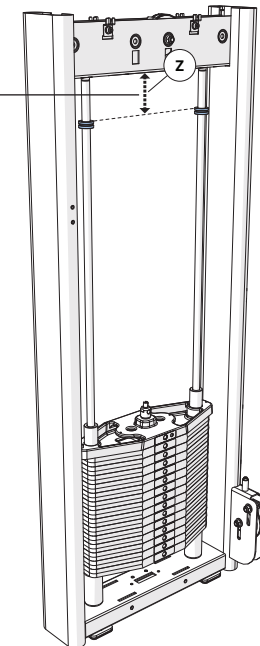



ASSEMBLY

4

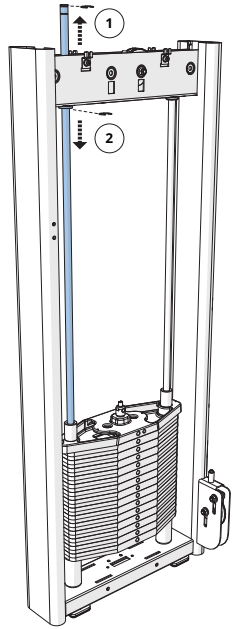

Torque Value
77 Nm / 59 ft-lb

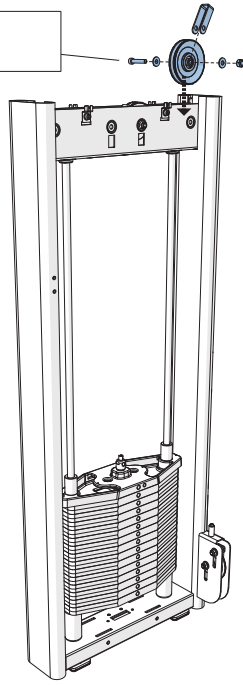

6

ADD-A-WEIGHT KIT (OPTIONAL)
* Not applicable for Medical units

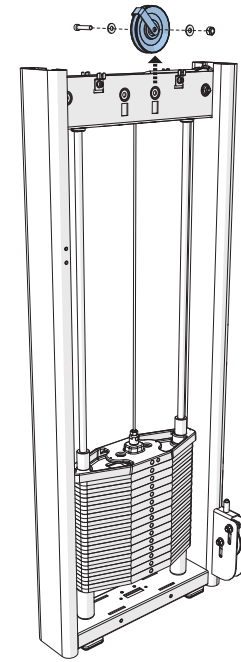
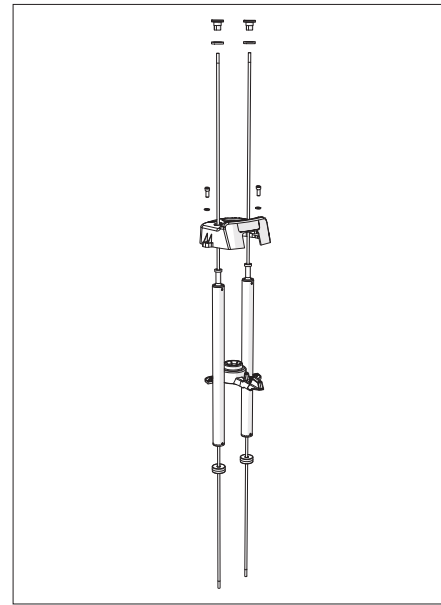

5

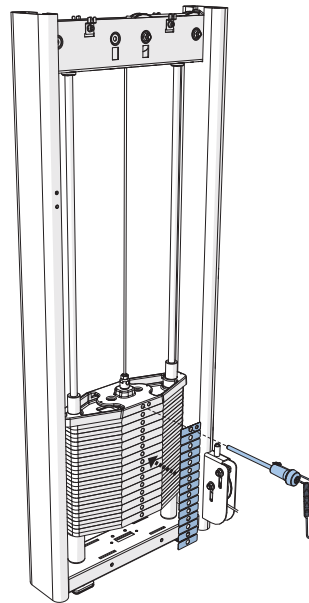
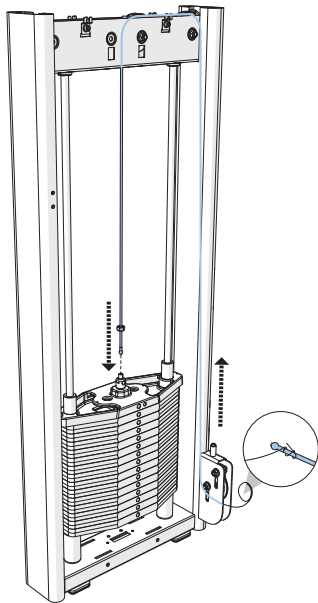

7

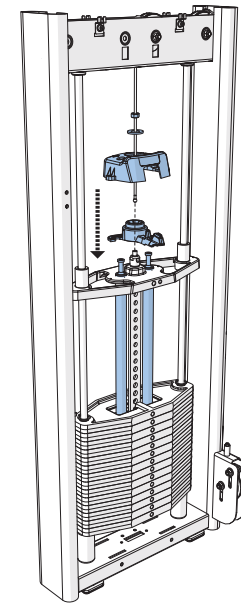
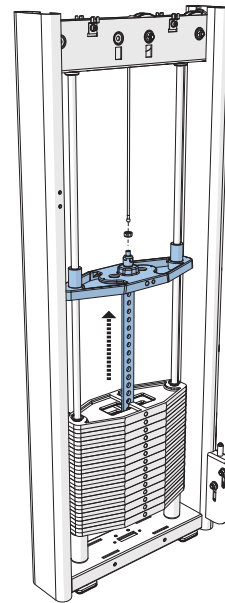



ASSEMBLY

8

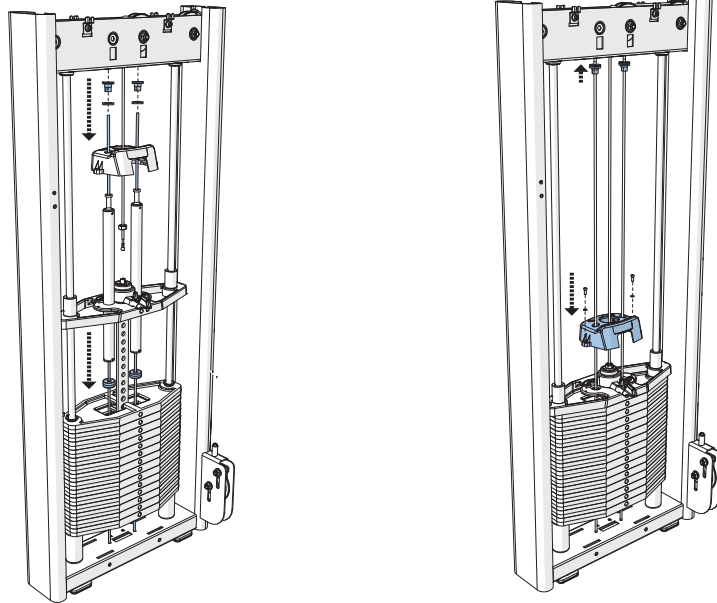

9

ADD-A-WEIGHT KIT ASSEMBLY COMPLETE

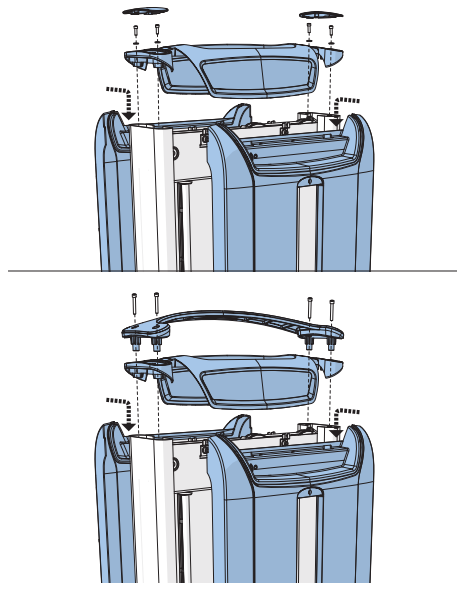
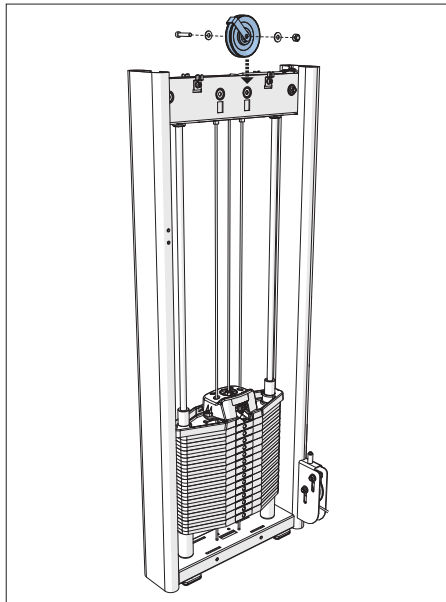

ASSEMBLY COMPLETE

1

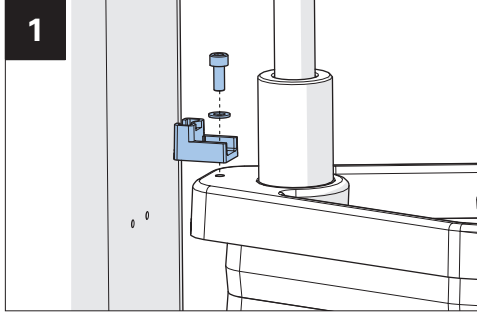

2

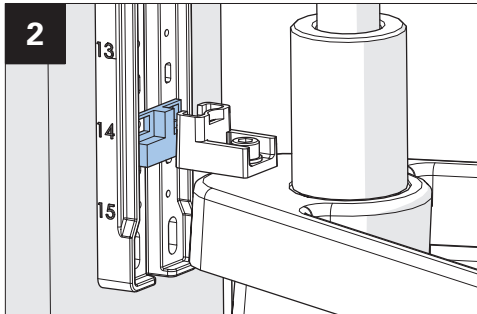

3

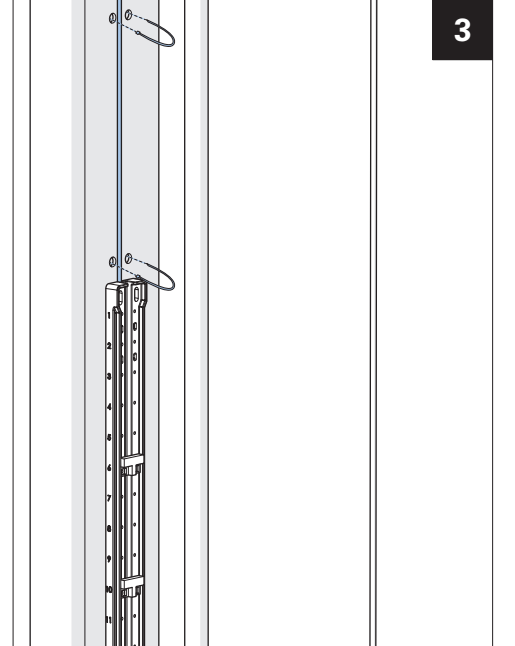

Model	Sensor Locations *
VS-S13 Chest Press	A2 ↓ B7 ↓ C13 ↓
VS-S23 Shoulder Press	A1 ↓ B4 ↑ C13 ↓
VS-S71 Leg Extension	A1 ↓ B7 ↓ C13 ↓
VS-S72 Seated Leg Curl	A6 ↓ B10 ↑ C13 ↓
VS-S70 Leg Press	A6 ↓ B10 ↓ C13 ↓
VS-S33 Lat Pull-down	A1 ↓ B3 ↑ C13 ↓
VS-S42 Triceps Press	A5 ↓ B8 ↑ C13 ↓
VS-S34 Seated Row	A1 ↓ B4 ↑ C13 ↓
VS-S40 Bicep Curl	A6 ↓ B8 ↓ C13 ↓
VS-S74 Hip Abductor/Adductor	A7 ↓ B11 ↑ C13 ↓
VS-S22 Pec Fly/Rear Delt	A7 ↓ B9 ↓ C13 ↓
VS-S53 Abdominal	A8 ↓ B10 ↓ C13 ↓
VS-S52 Back Extension	A6 ↓ B8 ↓ C13 ↓
VS-S78 Glute	A2 ↓ B7 ↓ C13 ↓
VS-S131 Multi-Press	A1 ↓ B5 ↓ C13 ↓
VS-S331 Lat Pulldown/Seated Row †	A13 ↓ B15 ↑ C13 ↓
VS-S401 Bicep/Triceps	A1 ↓ B3 ↑ C13 ↓
VS-S531 Ab/Back Extension	A9 ↓ B10 ↓ C13 ↓
VS-S601 Chin/Dip Assist	A1 ↓ B6 ↑ C13 ↓
VS-S711 Leg Extension/Seated Leg Curl	A5 ↑ B6 ↑ C13 ↓

* A = Top Sensor
 B = Middle Sensor
 C = Bottom Sensor
 † This model requires 2 sensor bases.
 A12 & A15 are installed on upper sensor base.

Not applicable for Medical units.

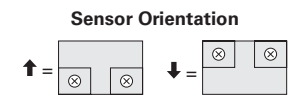

MATRIX



VERSA WEIGHT STACK

© 2022 Johnson Health Tech

Rev 2.0 A