

# ROGUE®

# FM-6 80" FUNCTIONAL TRAINER TWIN WEIGHT STACK

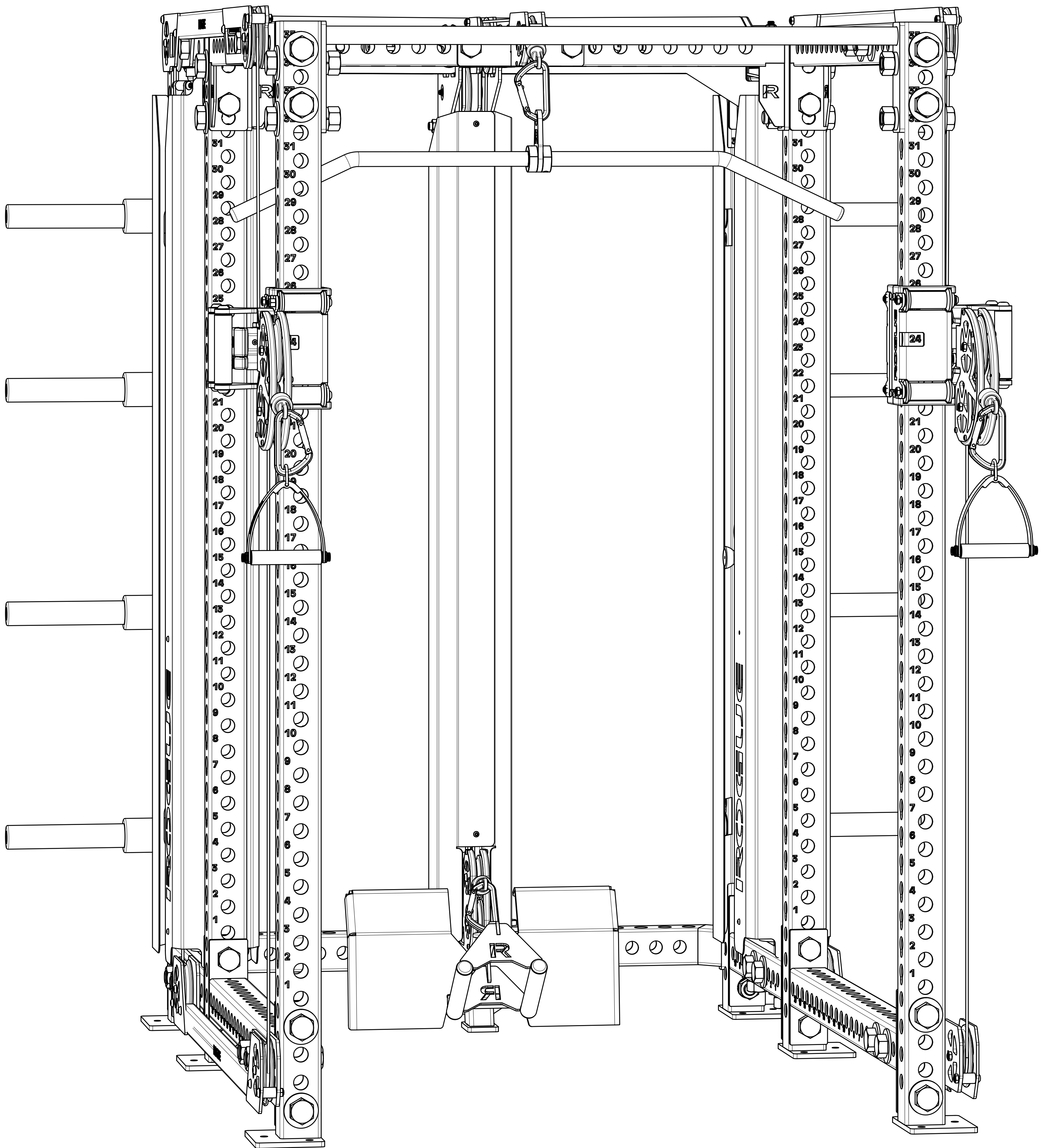

## ⚠ IMPORTANT SAFETY INFORMATION

### DISCLAIMER:

Resistance training, gymnastics training, and activities at height are potentially dangerous and may lead to severe injury or even death. Use common sense when training, obtain instruction in the proper execution of movements, and understand your limitations. This equipment must only be used by competent and responsible persons. Obtaining instruction in appropriate techniques and methods of use is your own responsibility. You assume all risks and responsibilities for all damage, injury or death which may occur during or following incorrect use of this equipment in any matter whatsoever. Rogue Fitness bears no liability beyond the replacement value of the equipment in question.

### WARNING:

**THIS RACK MUST BE BOLTED TO THE FLOOR BEFORE USE. MINIMUM TWO PEOPLE REQUIRED FOR SAFE ASSEMBLY. MISUSE OF THIS RACK CAN RESULT IN SEVERE INJURY.**

Both Rogue Fitness and buyer disclaim any express or implied warranty, including, without limitation, warranties or merchantability and/or fitness for a particular purpose with respect to the equipment. Buyer assumes all liability to use of equipment.

# TABLE OF CONTENTS

## RM-6 RACK

Included Tools.....	3
Included Parts.....	4
Assembly.....	14

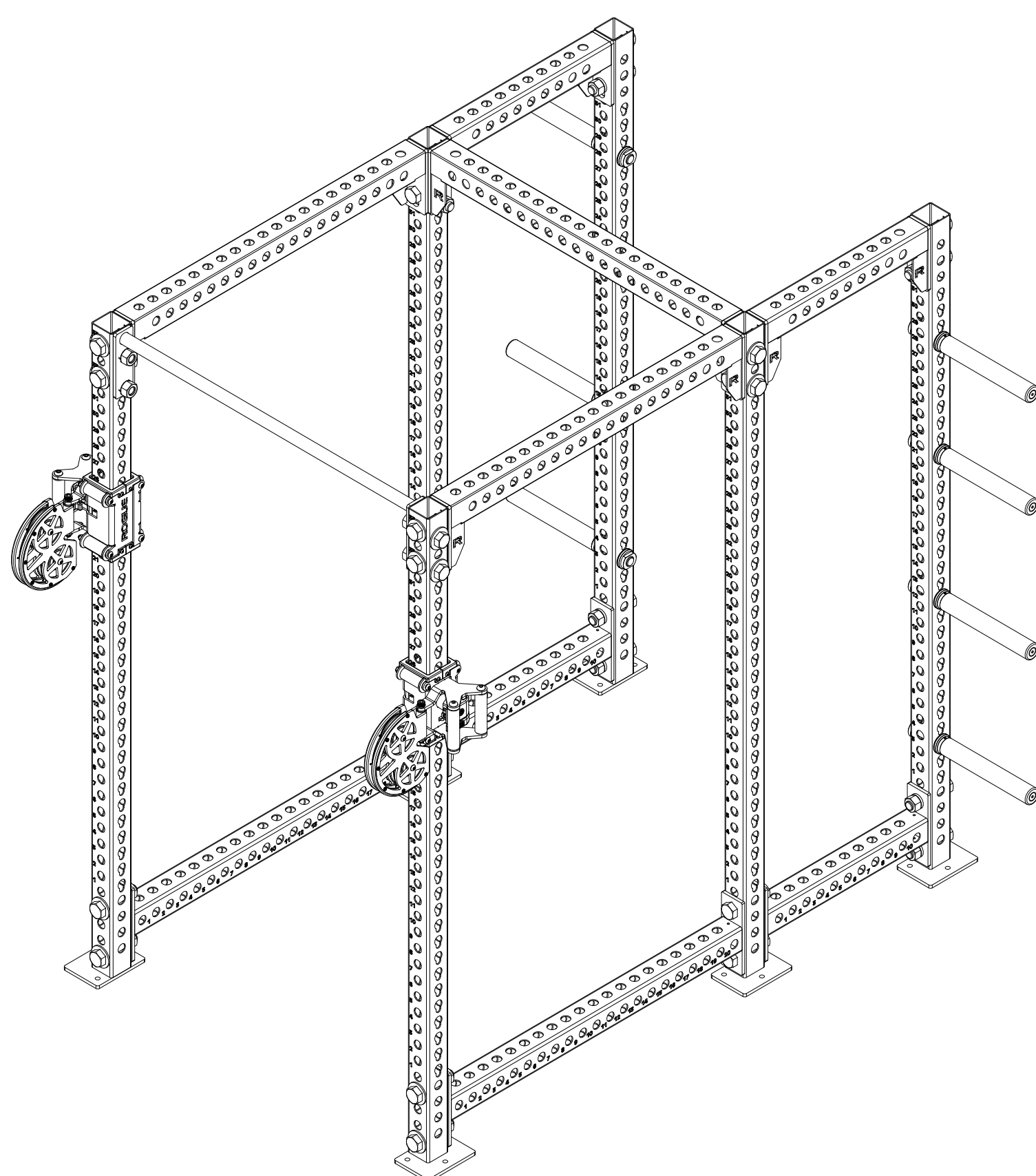

## FM-6 ADD-ON KIT

Included Tools.....	3
Included Parts.....	6
Assembly.....	19

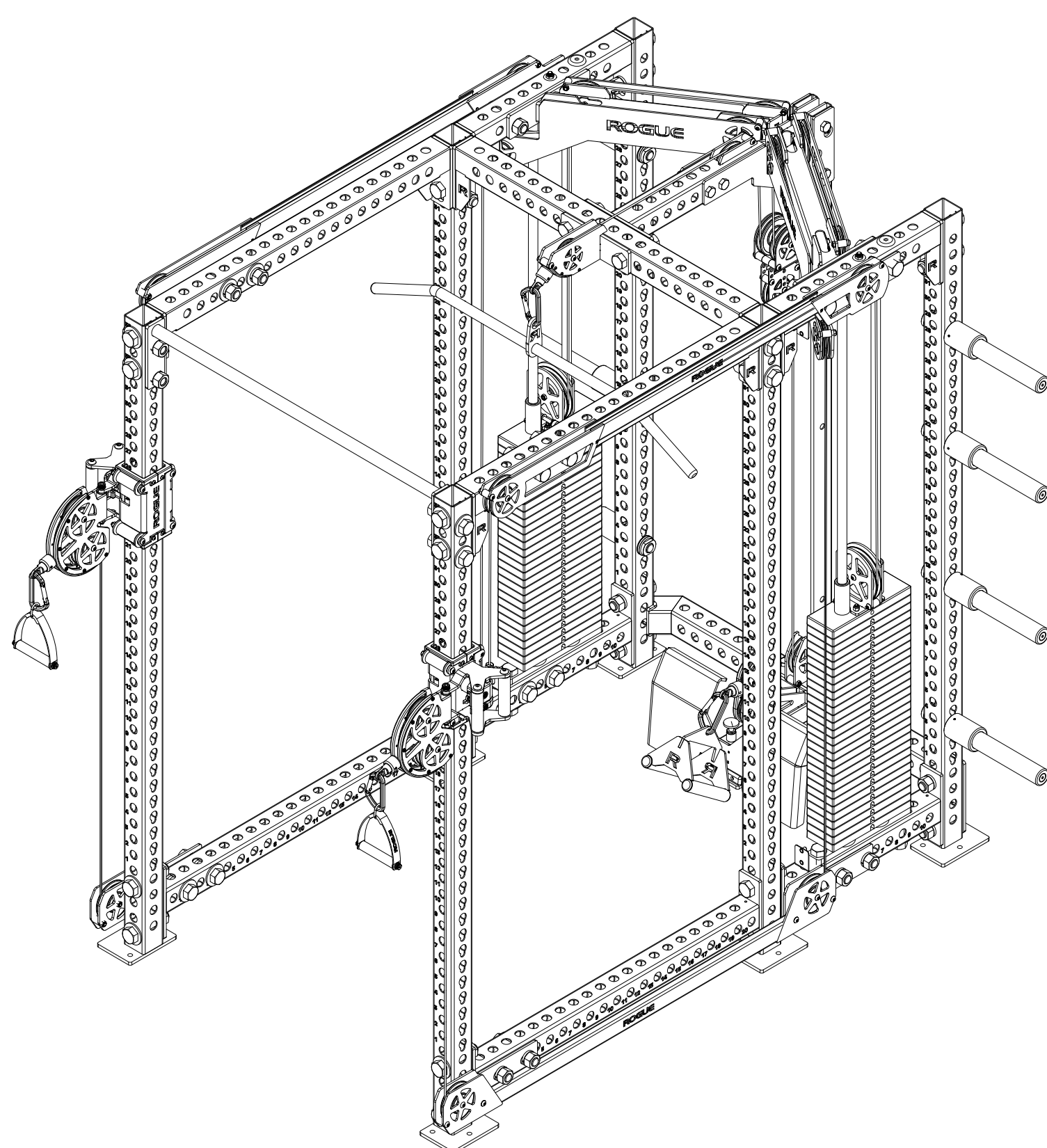

## FM-6 SHROUD KIT

Included Tools.....	3
Included Parts.....	11
Assembly.....	46

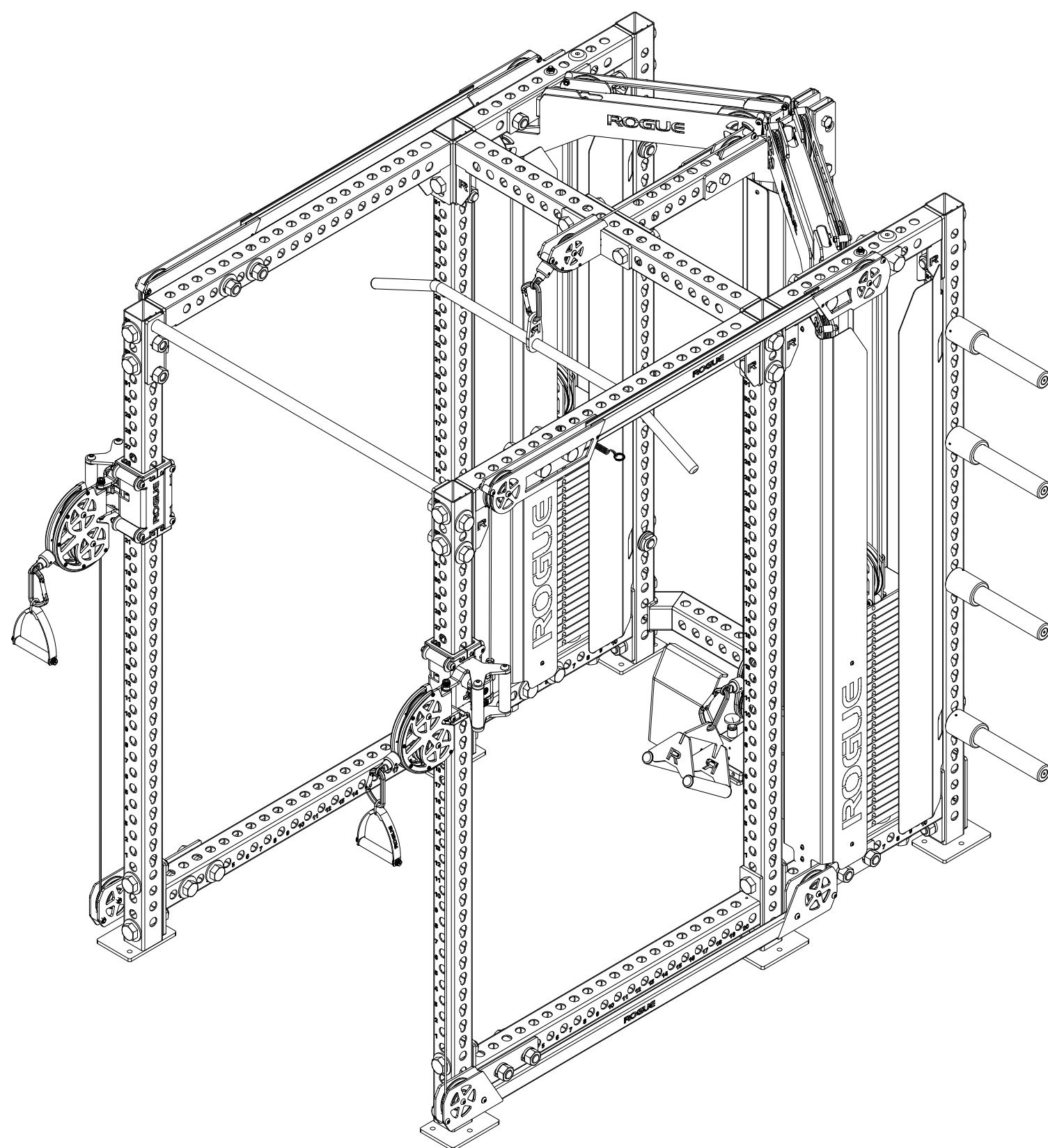

# INCLUDED TOOLS

Note: Images not shown at scale

**1** Qty: **2x**

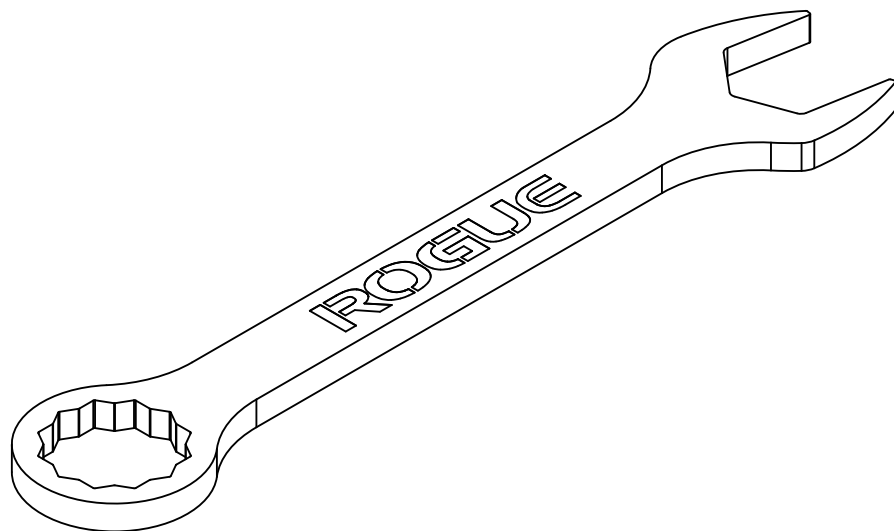

1-1/2" Wrench

A line drawing of a 1-1/2 inch open-end wrench. The handle is long and tapers slightly towards the head. The word "ROGUE" is printed in capital letters along the handle. The head has two open ends with six teeth each.

**2** Qty: **2x**

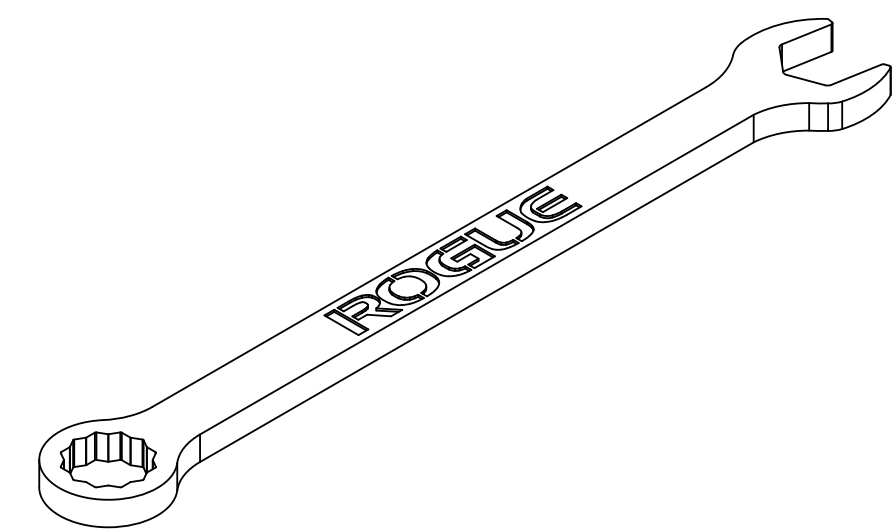

15/16" Wrench

A line drawing of a 15/16 inch open-end wrench. The handle is long and tapers slightly towards the head. The word "ROGUE" is printed in capital letters along the handle. The head has two open ends with six teeth each.

**3** Qty: **1x**

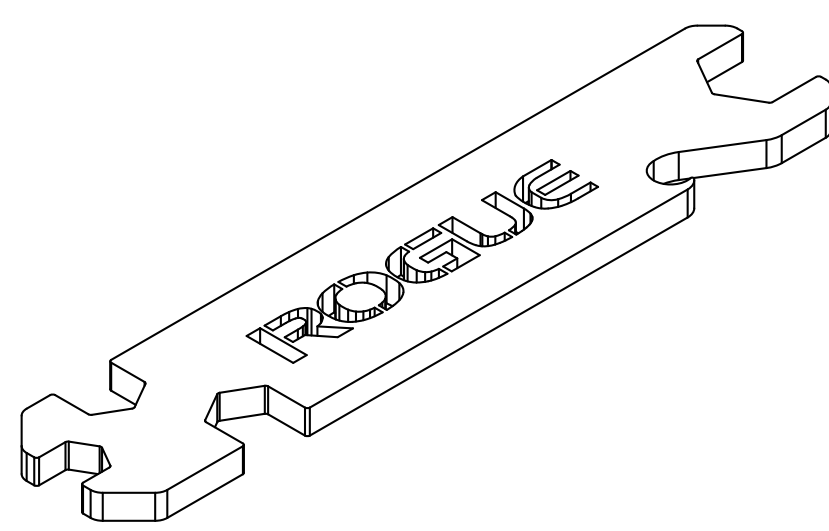

Multi Tool (3/4", 9/16", 5/8" and 7/16" Wrench)

A line drawing of a multi-tool wrench. The handle is long and tapers slightly towards the head. The word "ROGUE" is printed in capital letters along the handle. The head has four different sized open ends with six teeth each.

**4** Qty: **1x**



3/8" Allen Key

A line drawing of a 3/8 inch hex Allen key. It is a long, thin metal rod with a hexagonal cross-section and a 60-degree angle at the end.

**5** Qty: **1x**

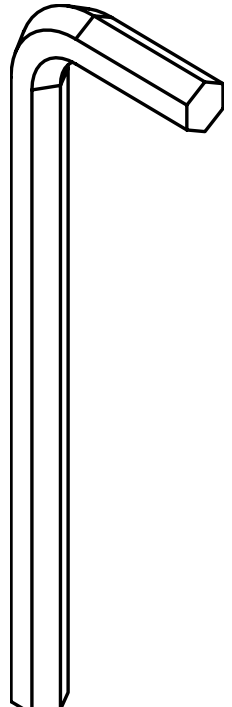

5/16" Allen Key

A line drawing of a 5/16 inch hex Allen key. It is a long, thin metal rod with a hexagonal cross-section and a 60-degree angle at the end.

**6** Qty: **1x**

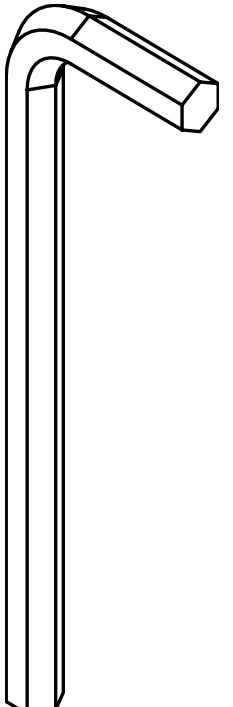

7/32" Allen Key

A line drawing of a 7/32 inch hex Allen key. It is a long, thin metal rod with a hexagonal cross-section and a 60-degree angle at the end.

**7** Qty: **1x**



5/32" Allen Key

A line drawing of a 5/32 inch hex Allen key. It is a long, thin metal rod with a hexagonal cross-section and a 60-degree angle at the end.

**8** Qty: **1x**

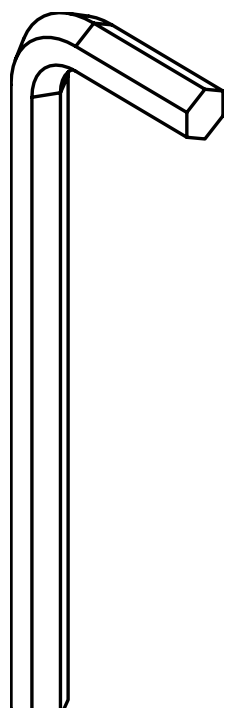

1/8" Allen Key

A line drawing of a 1/8 inch hex Allen key. It is a long, thin metal rod with a hexagonal cross-section and a 60-degree angle at the end.

**9** Qty: **1x**

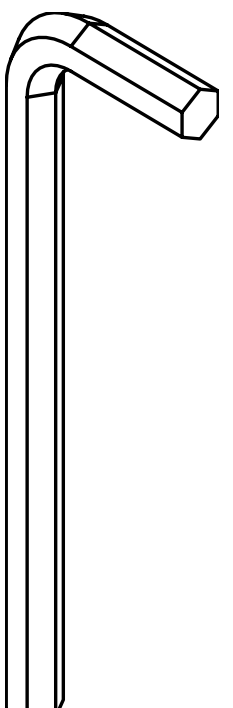

3/32" Allen Key

A line drawing of a 3/32 inch hex Allen key. It is a long, thin metal rod with a hexagonal cross-section and a 60-degree angle at the end.

# INCLUDED PARTS: RM-6 FULL RACK

Note: Images not shown at scale.

**1** Qty: **6x**

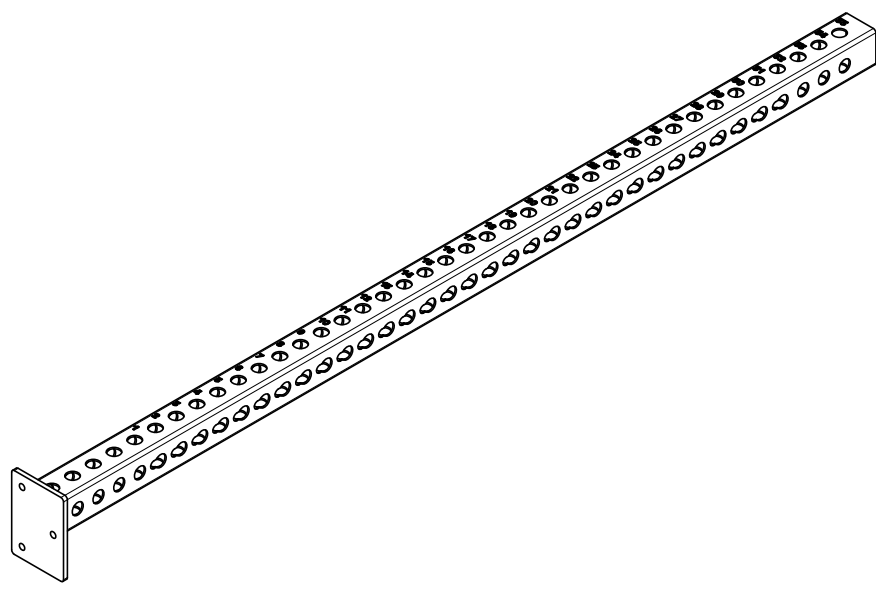

80" Monster Upright

**2** Qty: **2x**

\*

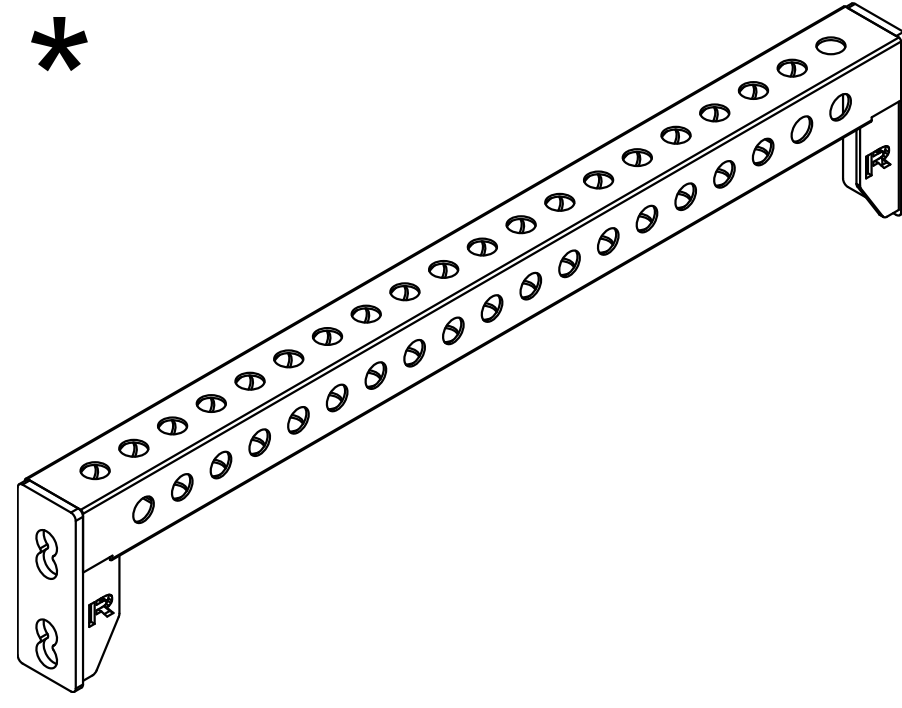

Front Top Crossmember

**3** Qty: **2x**

\*

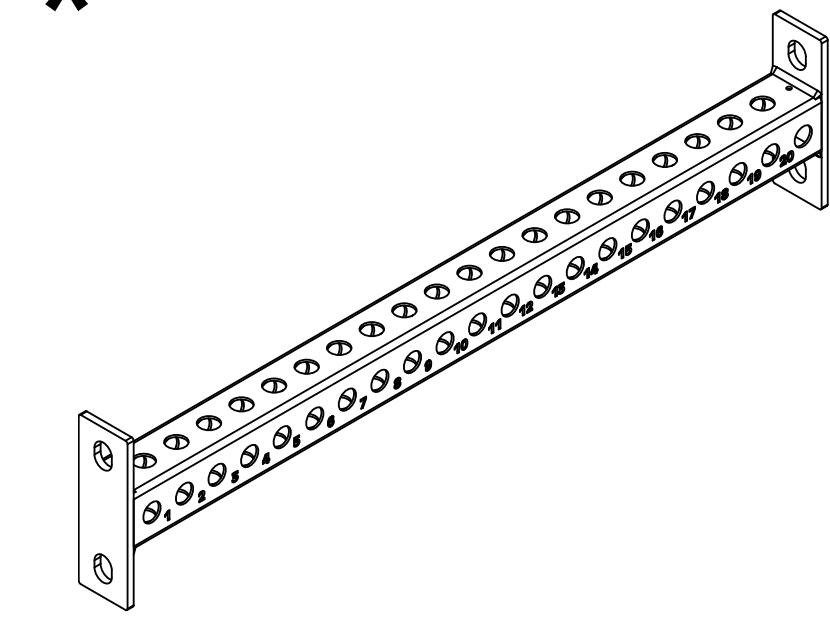

Front Low Crossmember

**4** Qty: **2x**

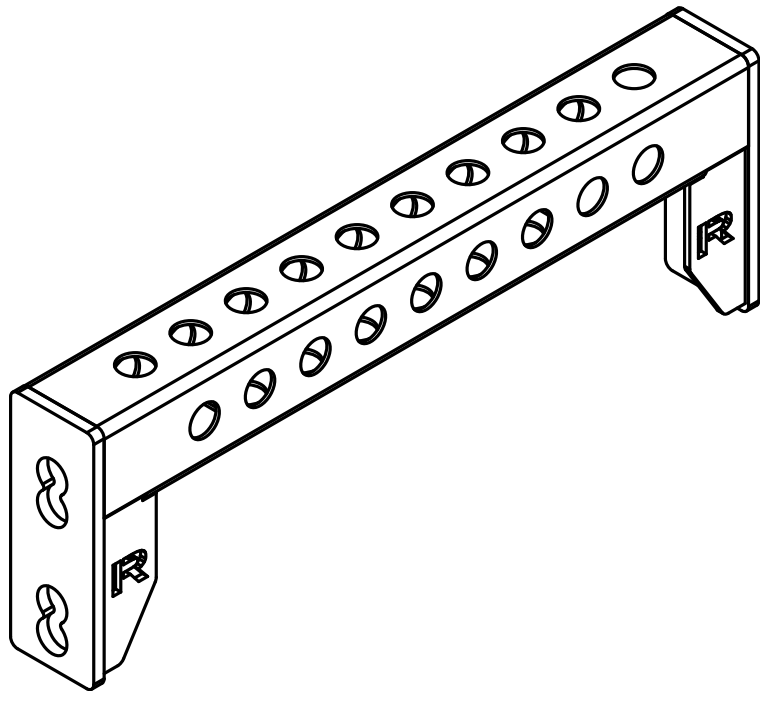

24" Rear Top Crossmember

**5** Qty: **2x**

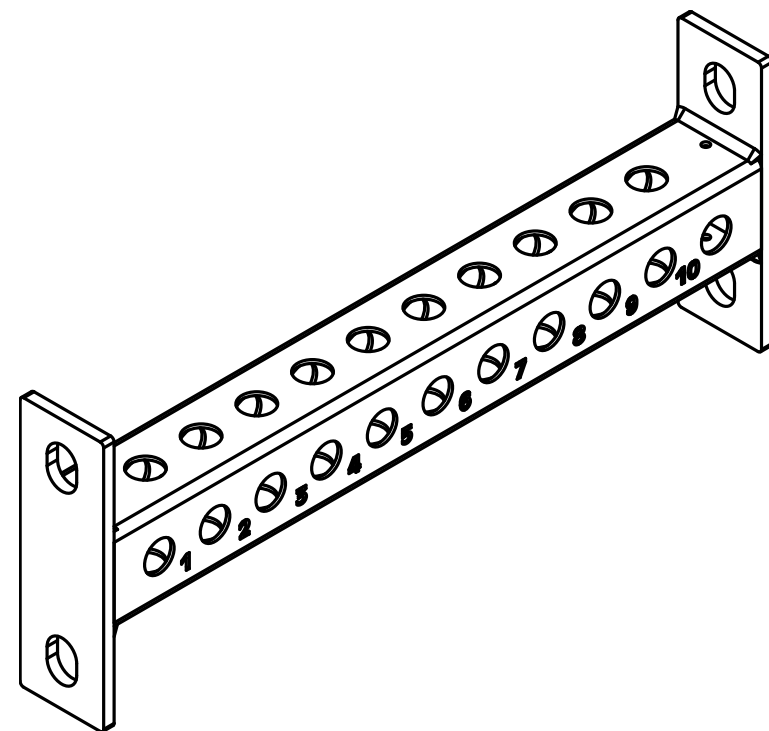

24" Rear Low Crossmember

**6** Qty: **1x**

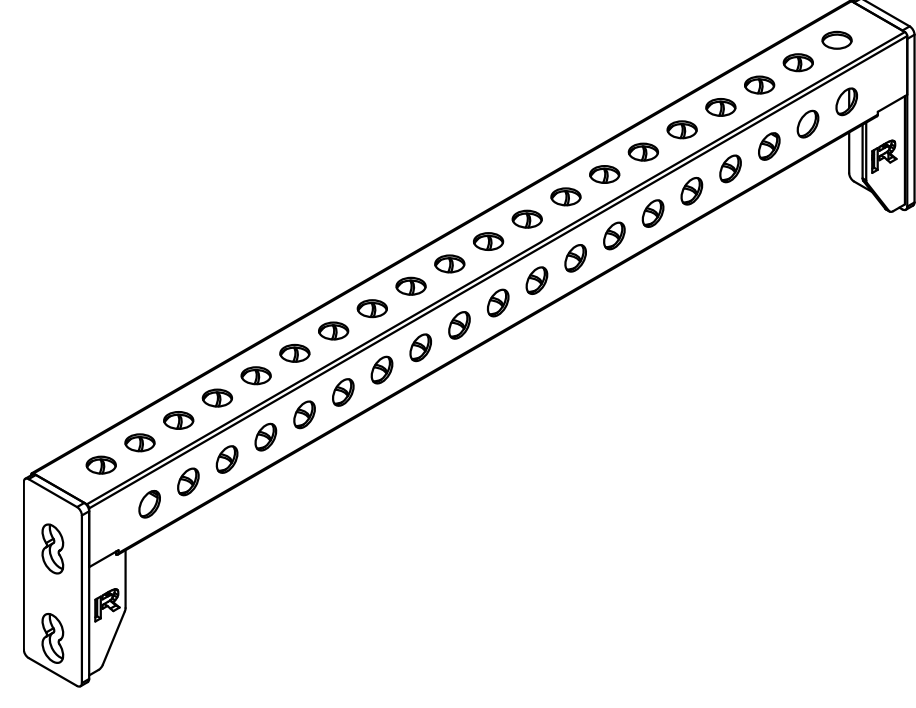

Top Center Crossmember

**7** Qty: **1x**

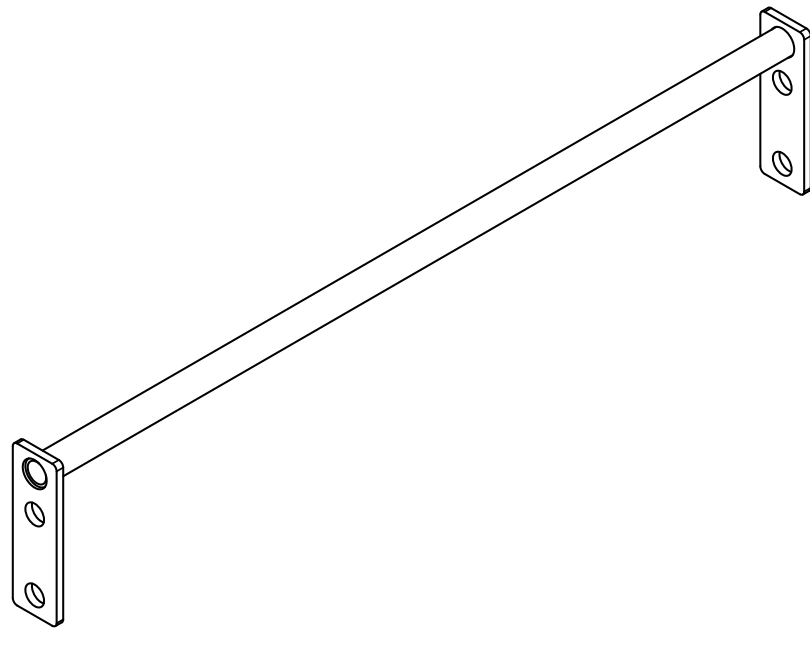

Pull-up Bar

**8** Qty: **8x**



Monster Plate Storage Pin

**9** Qty: **1x**

\*\*



Pair of Safety Spotter Arms

**10** Qty: **4x**

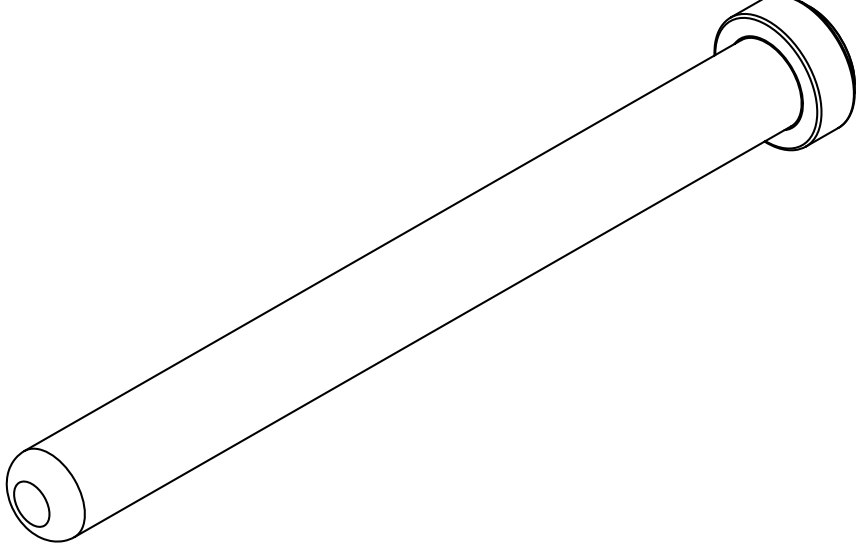

Band Peg

**11** Qty: **1x**

\*\*

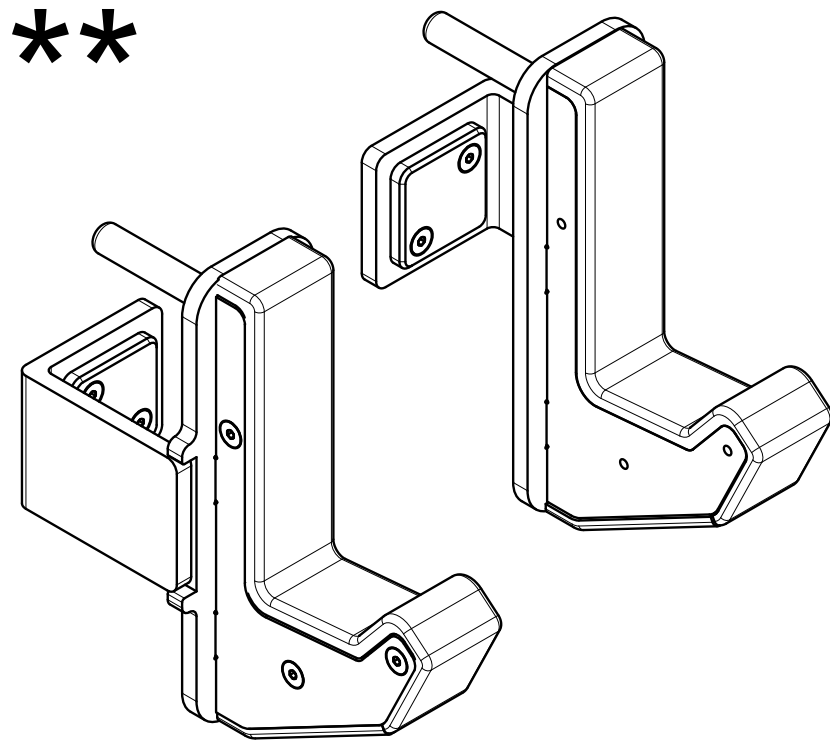

Pair of Monster J-cups

**12** Qty: **8x**

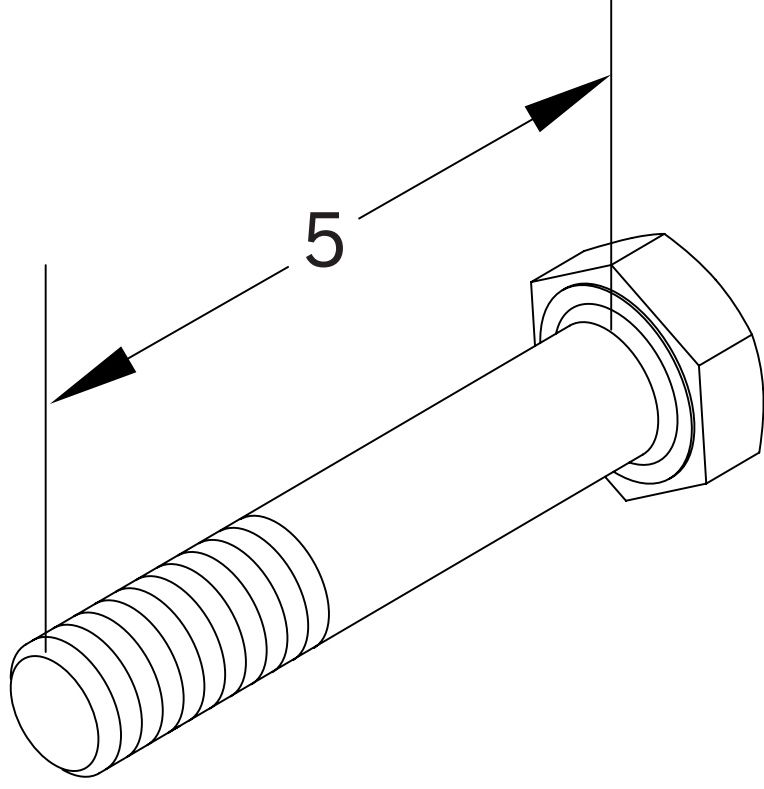

1" x 5" Hex Bolt

\* Front Crossmember length depends on Rack Depth selection made at checkout.

\*\* Items may look different than drawings shown. Style depends on selection made at checkout.

# INCLUDED PARTS: RM-6 FULL RACK

Note: Images not shown at scale.

**13** Qty: **24x**

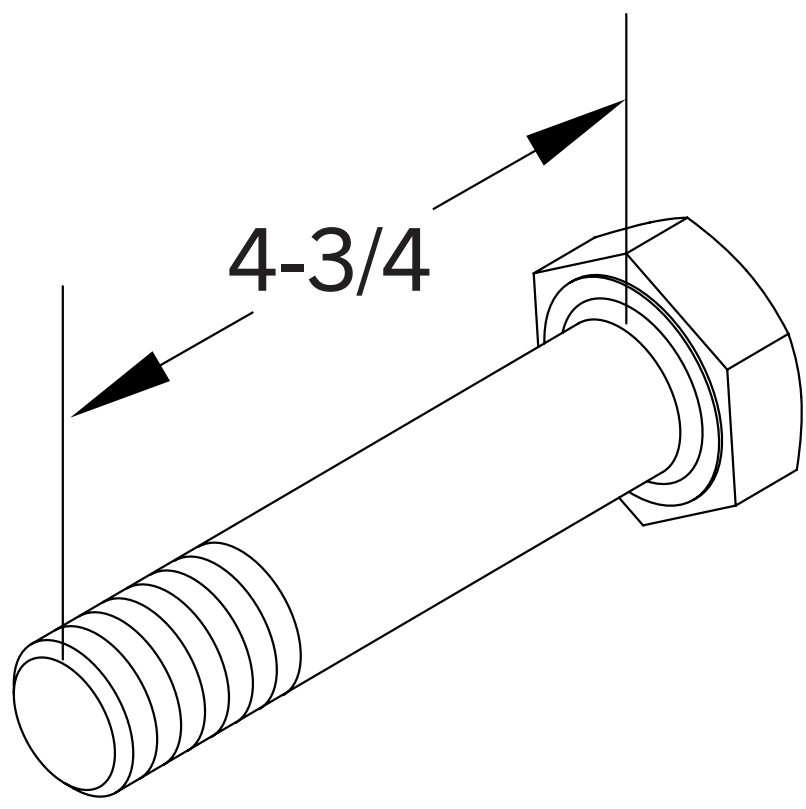

1" x 4-3/4" Hex Bolt

**14** Qty: **24x**

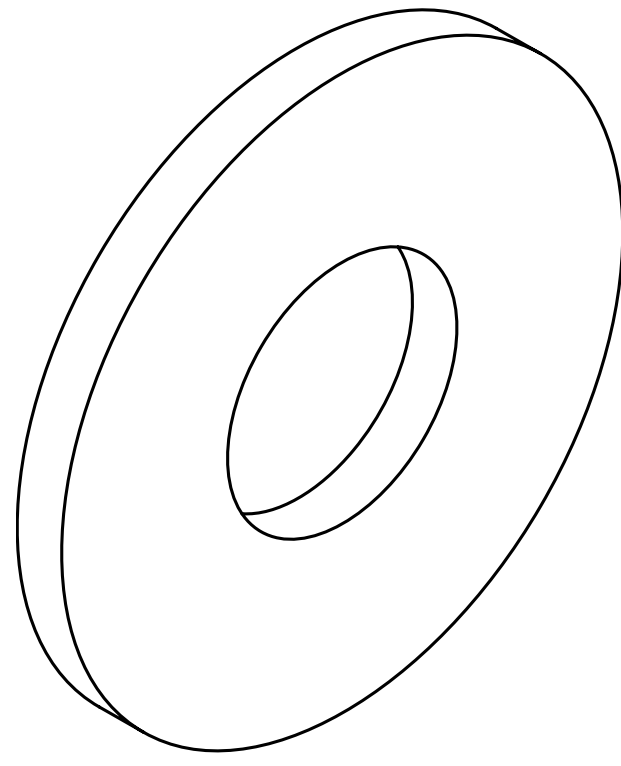

1" Flat Washer

**15** Qty: **32x**

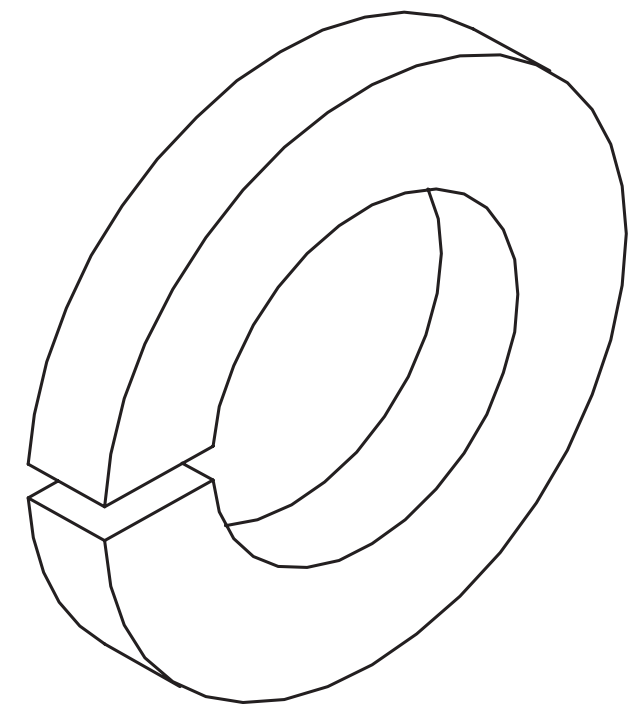

1" Lock Washer

**16** Qty: **32x**

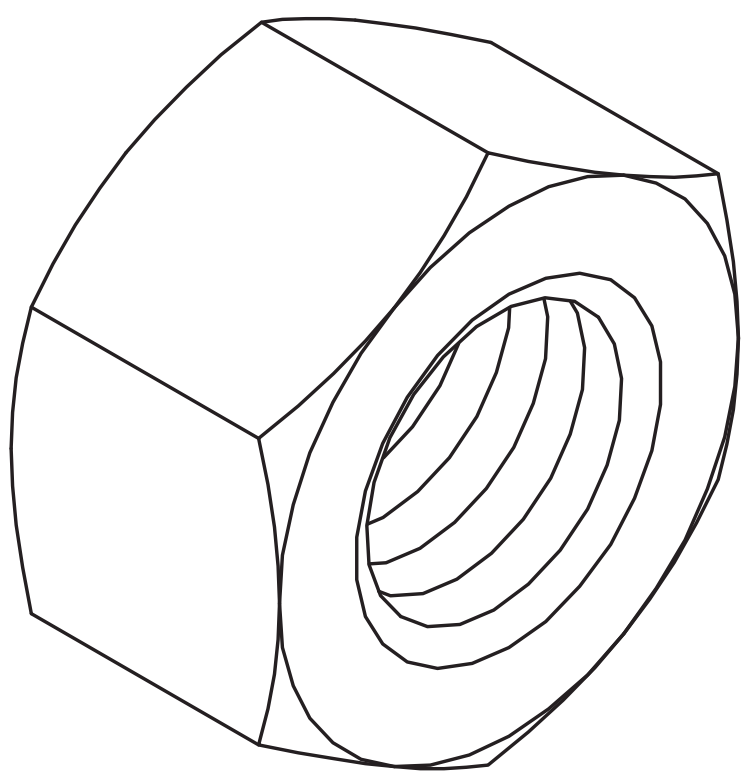

1" Hex Nut

# INCLUDED PARTS: FM-6 ADD-ON KIT

Note: Images not shown at scale.

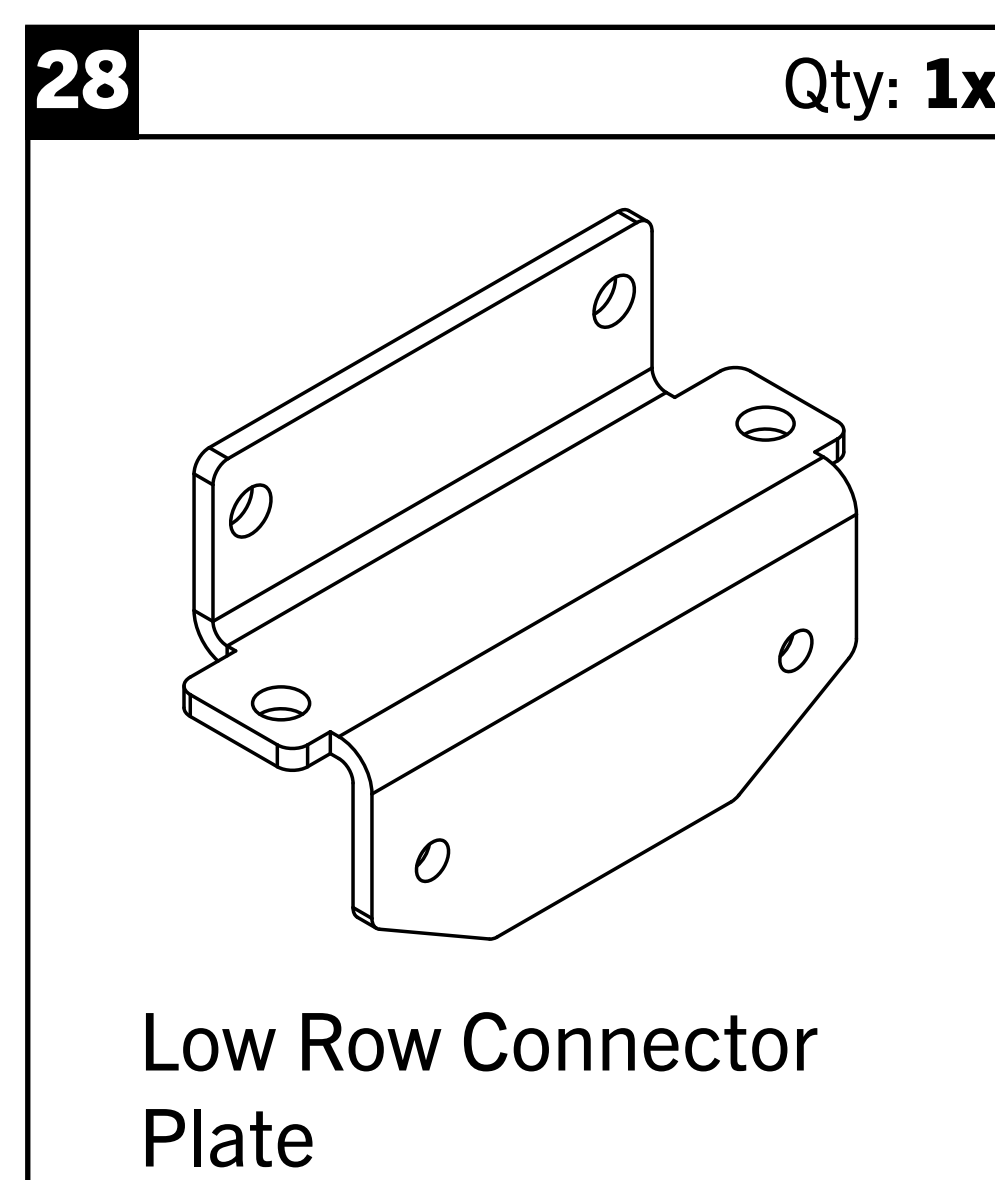
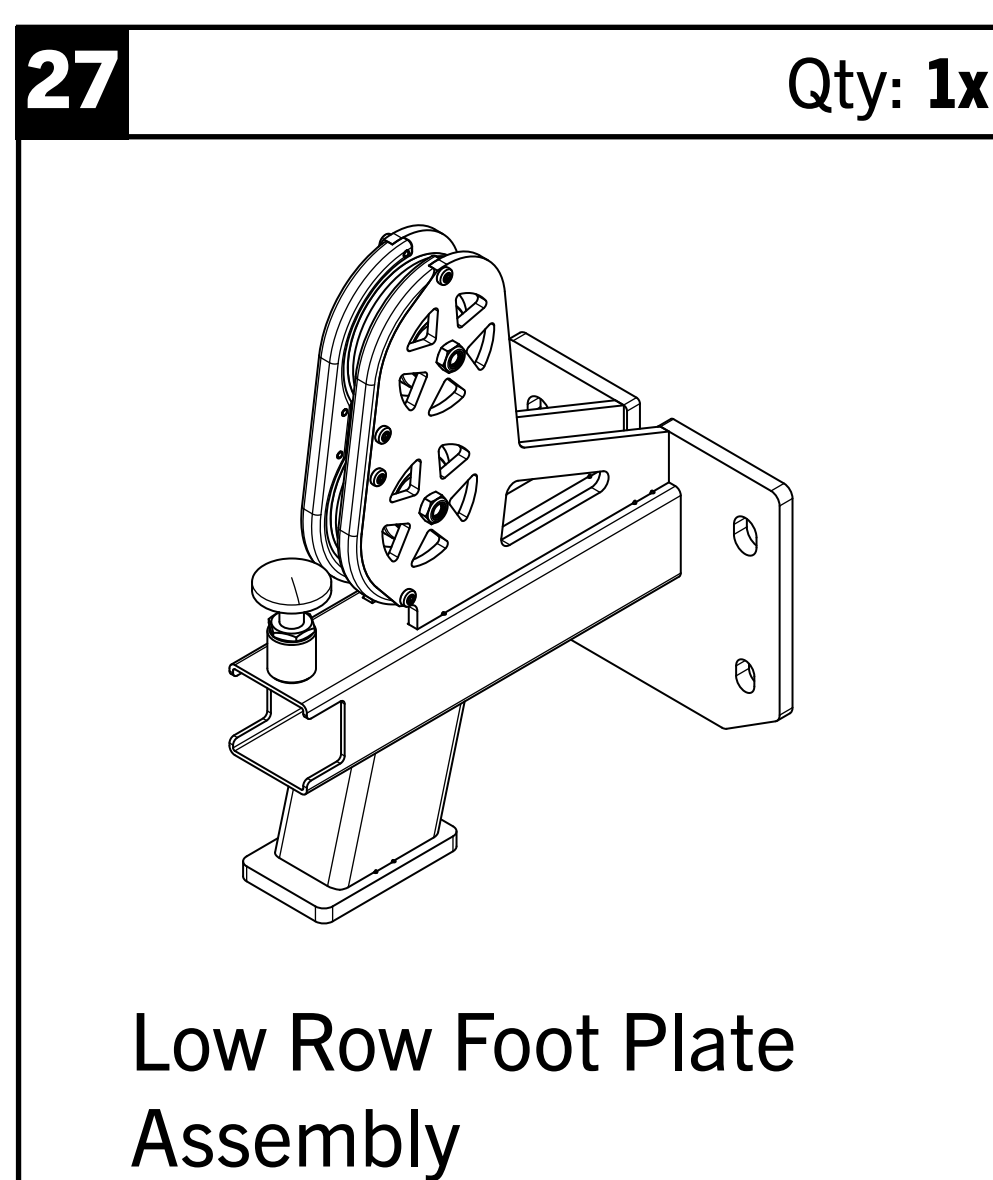
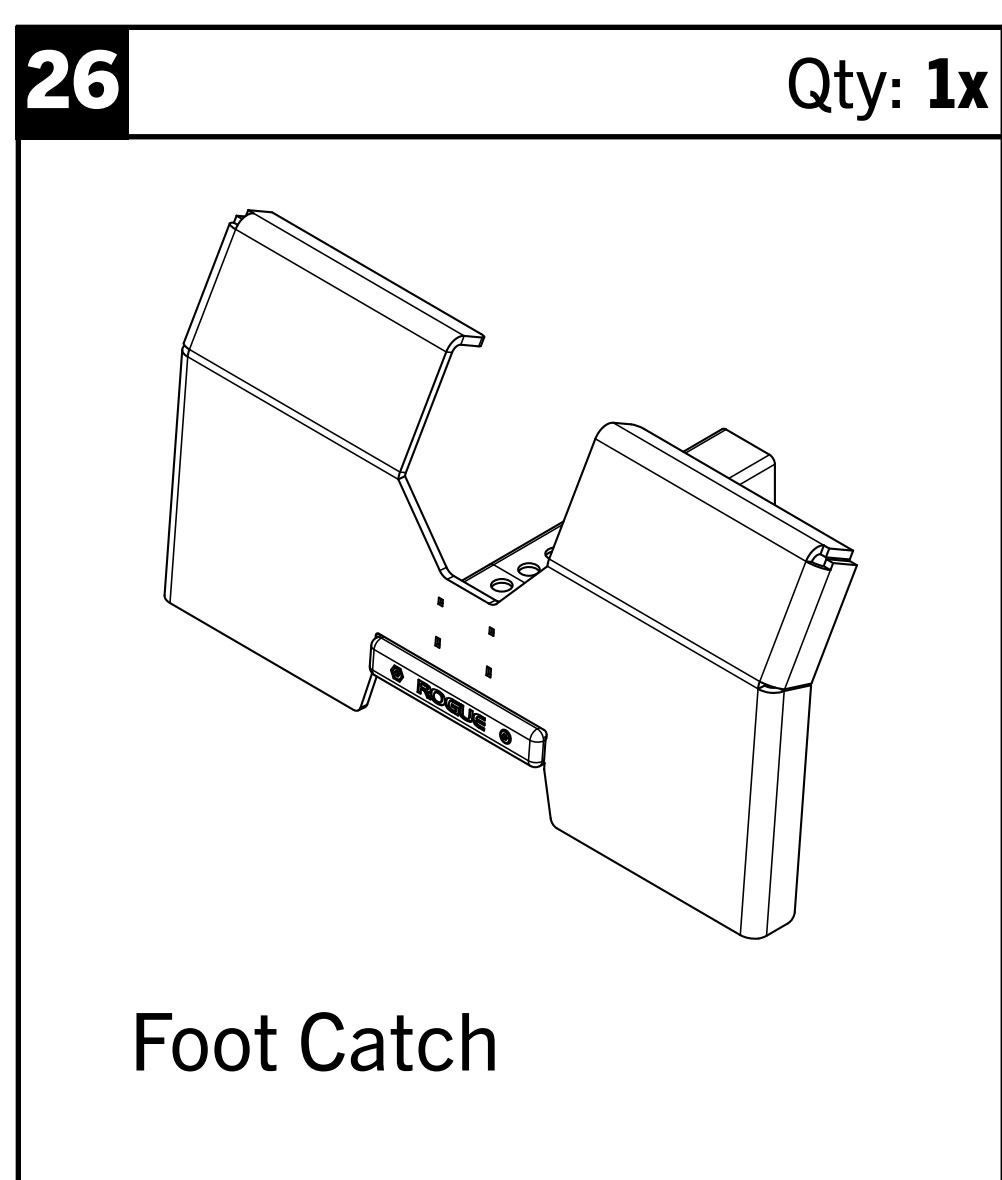
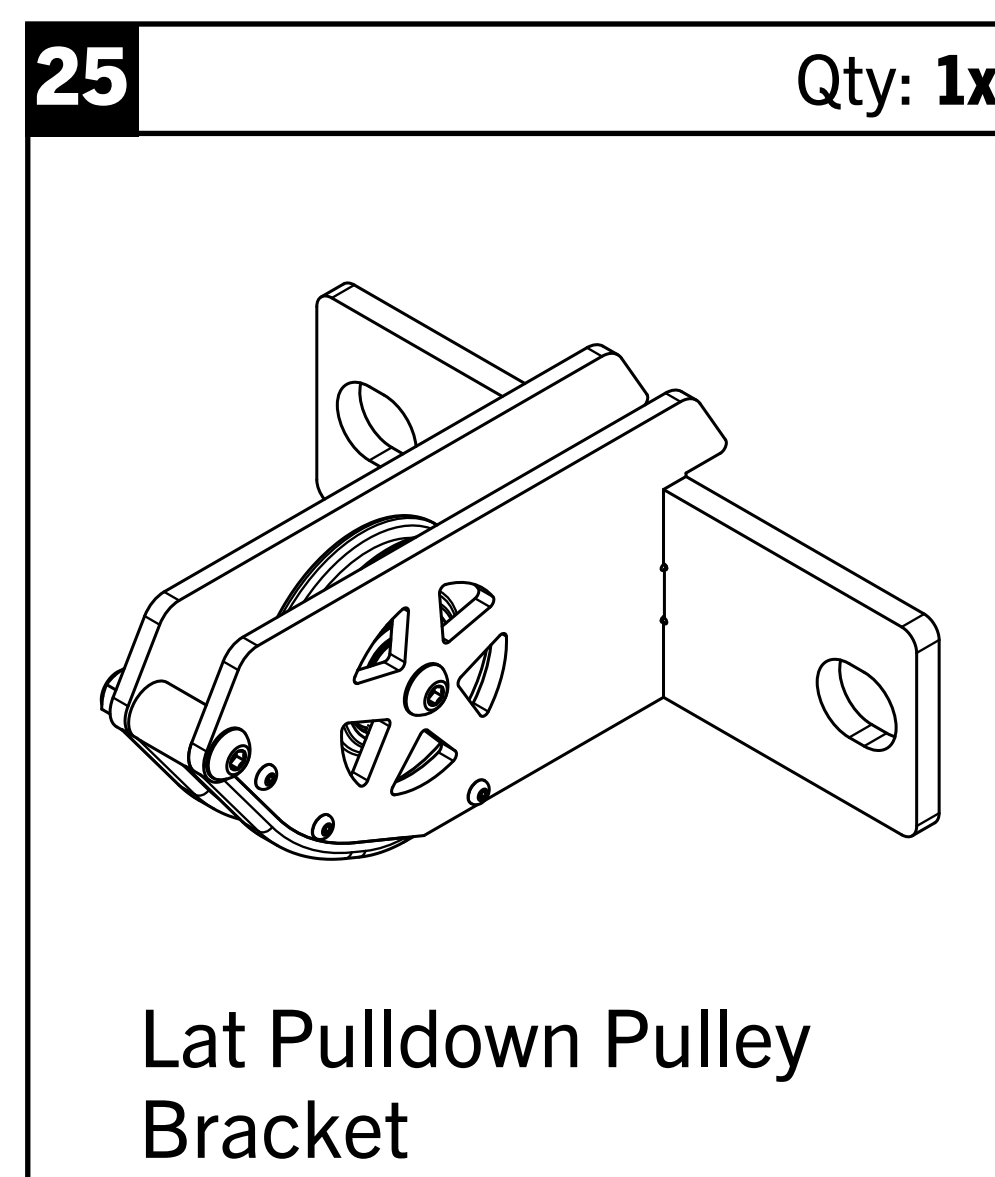
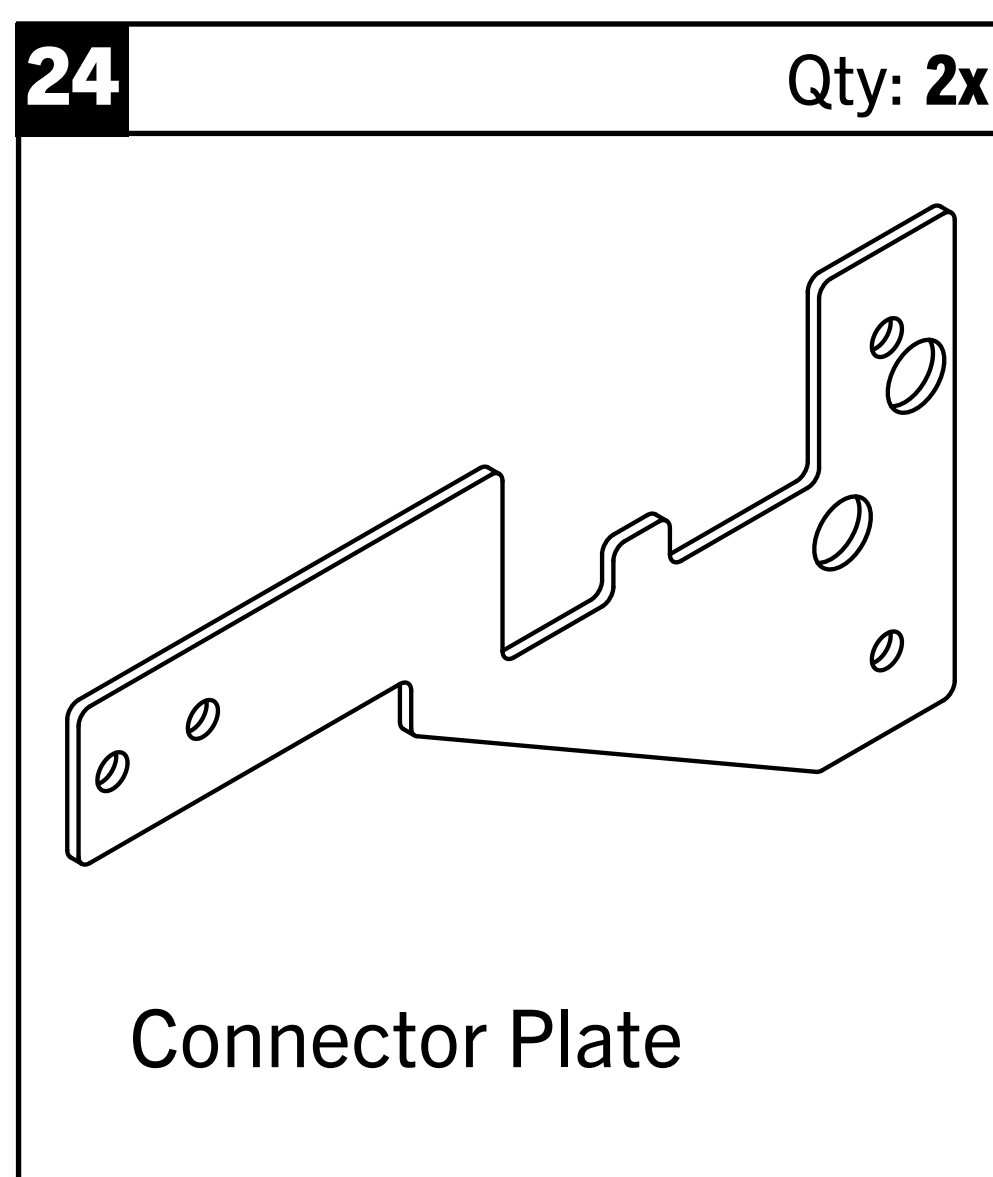
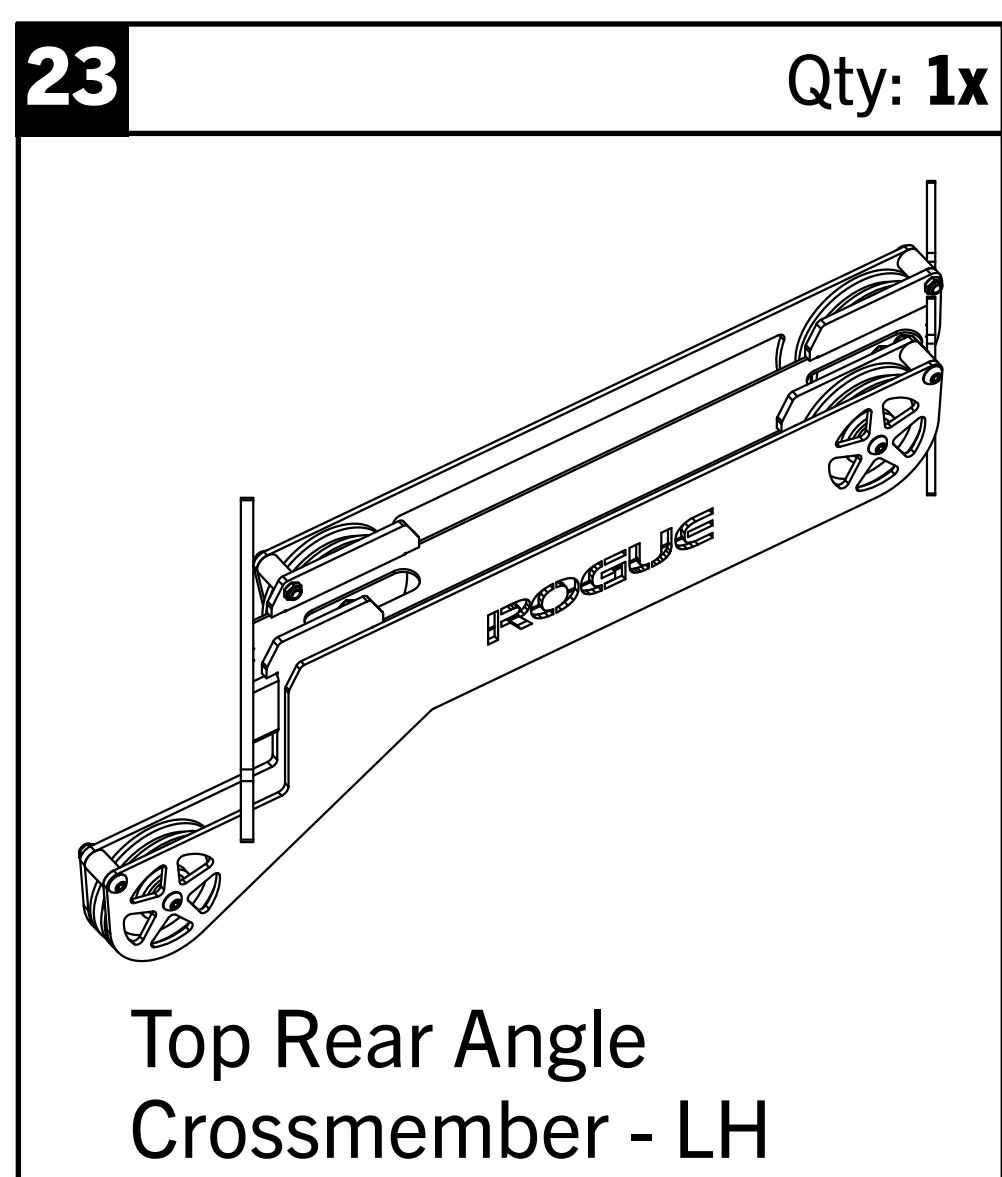
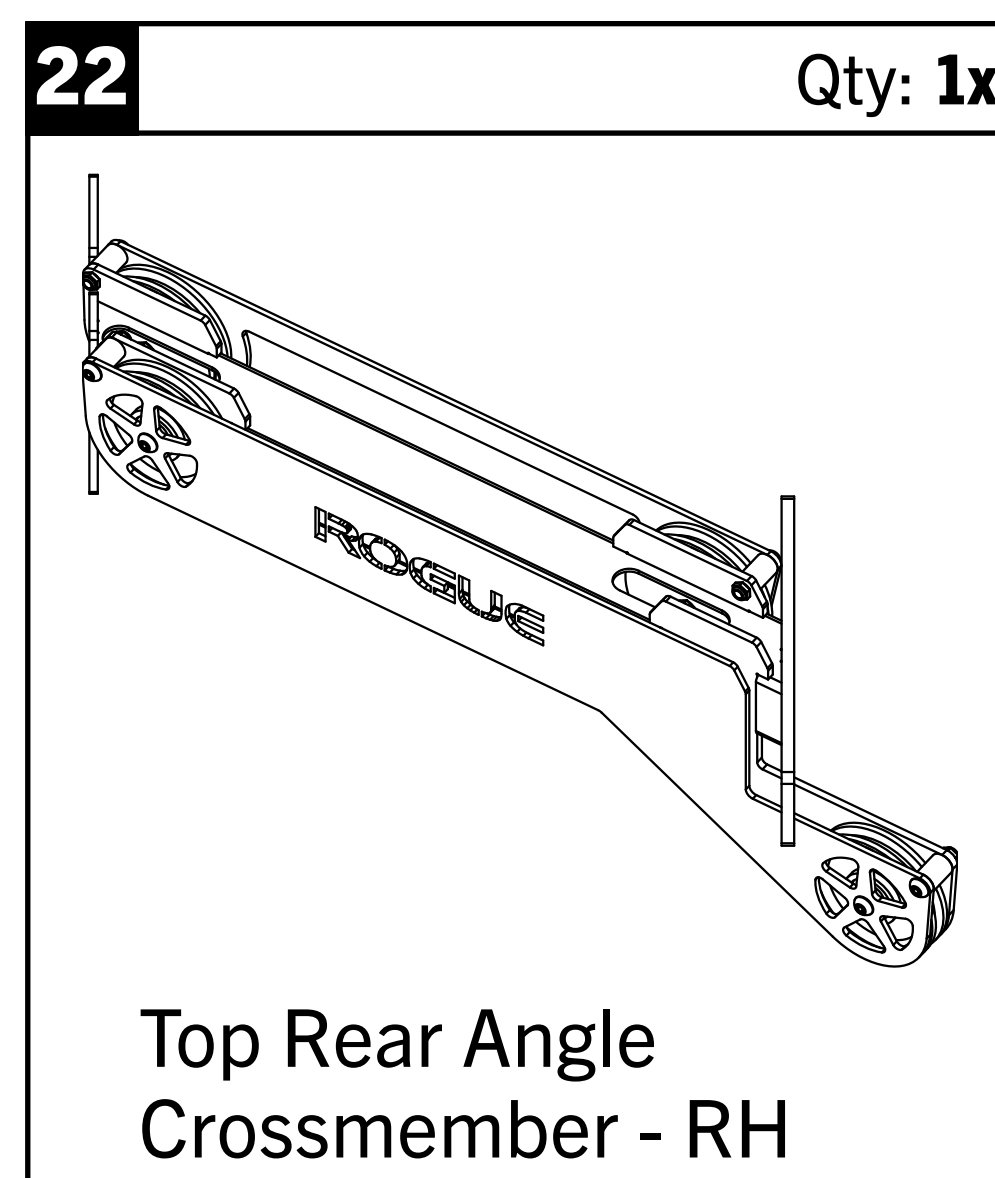
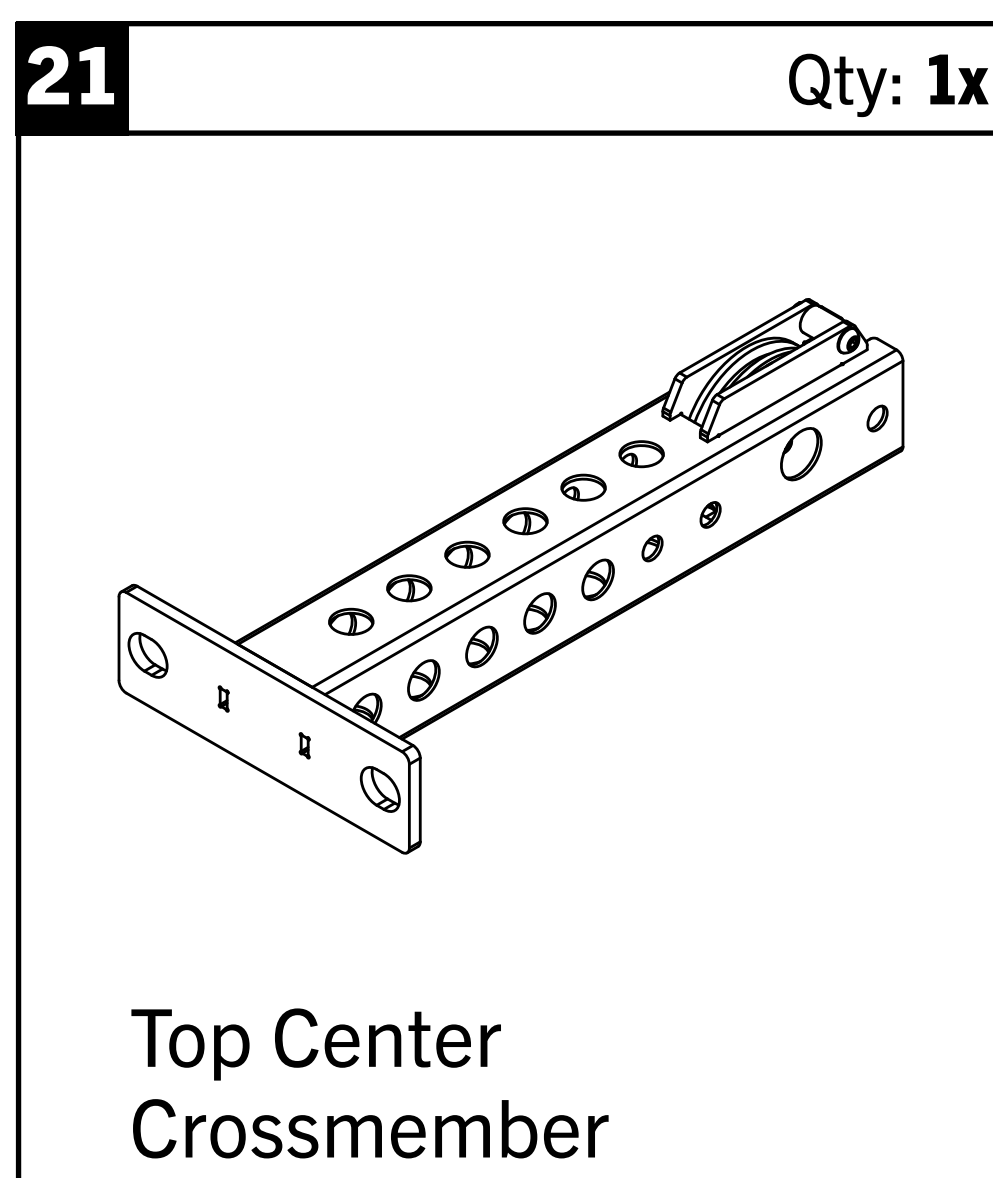
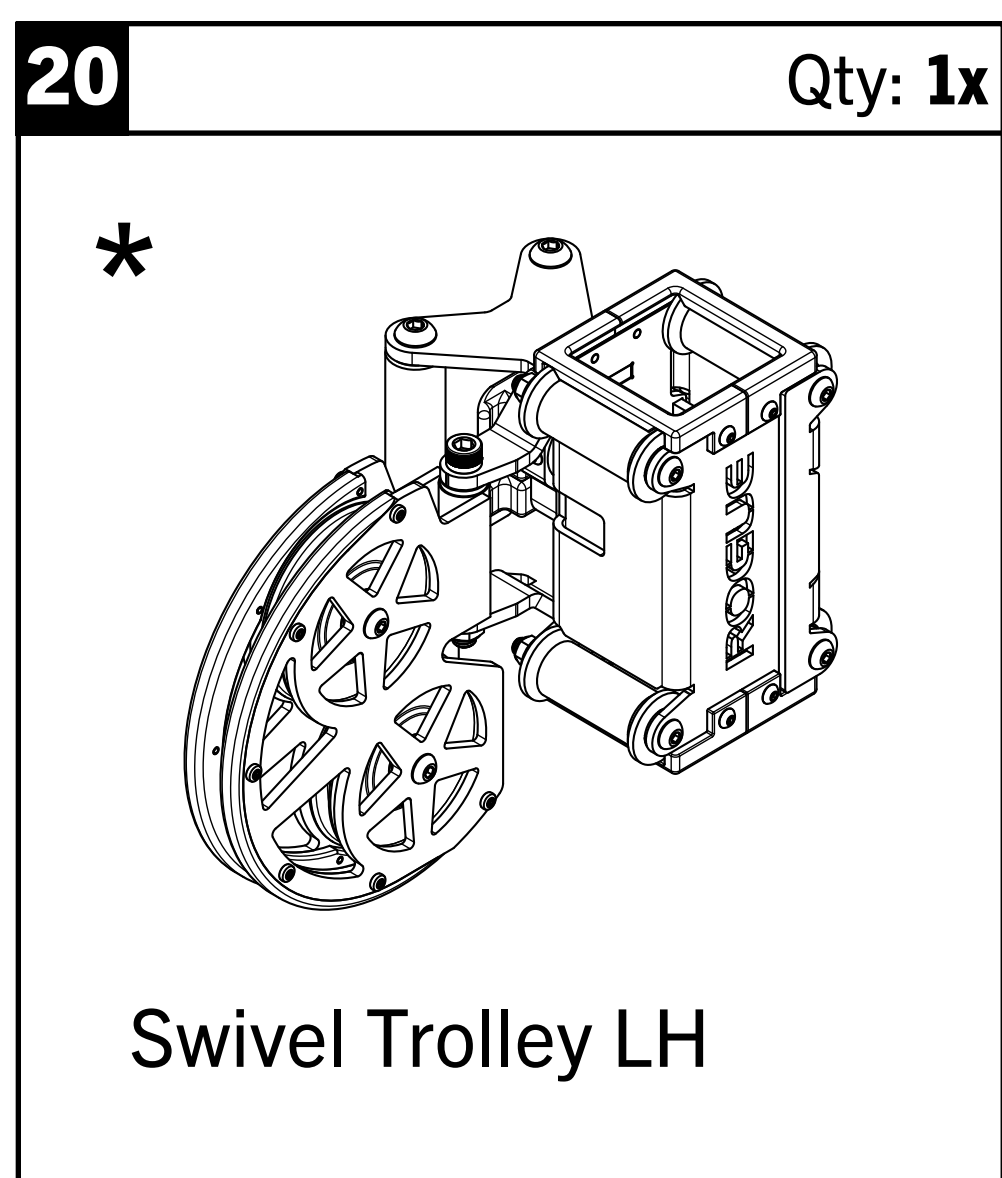
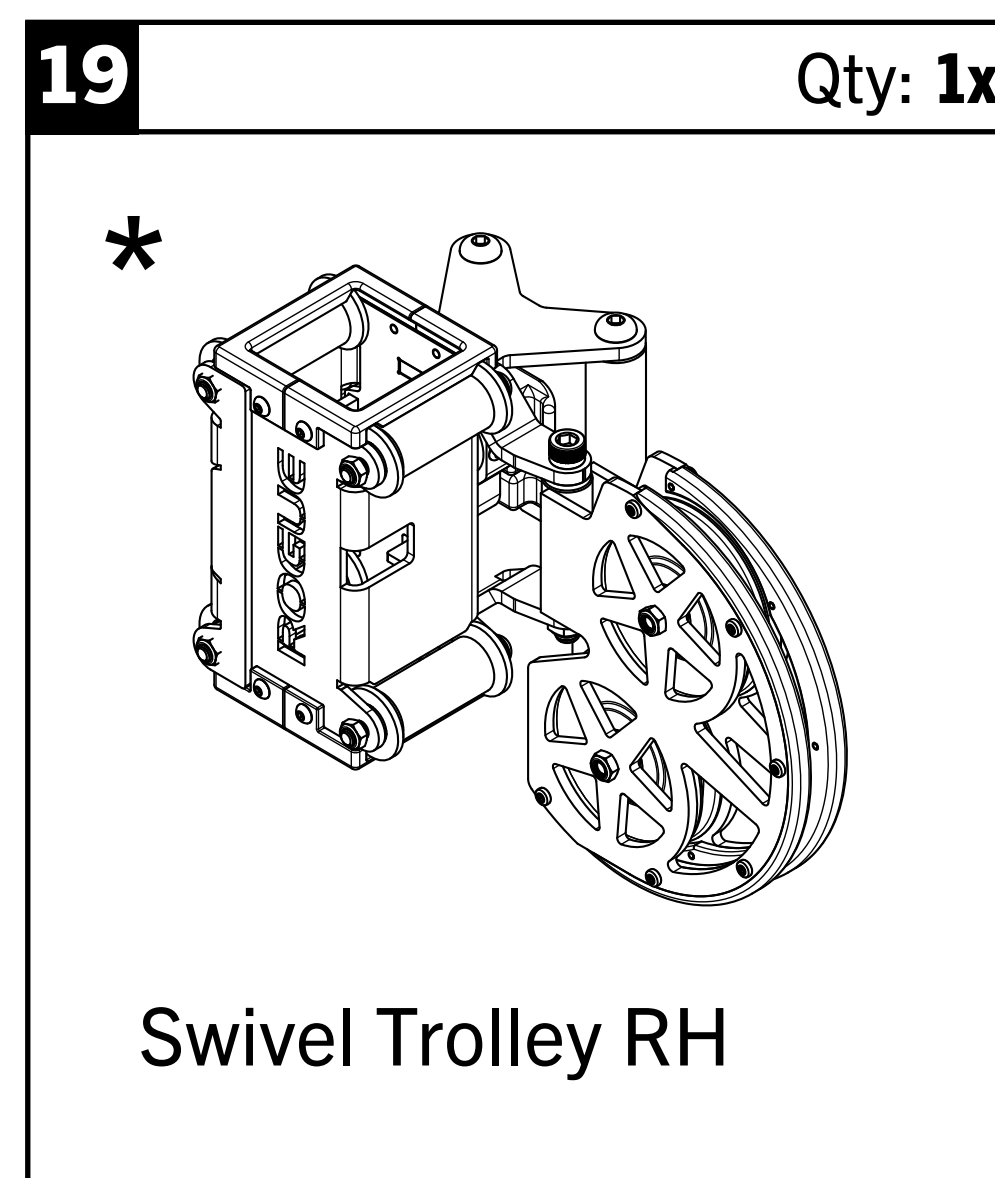
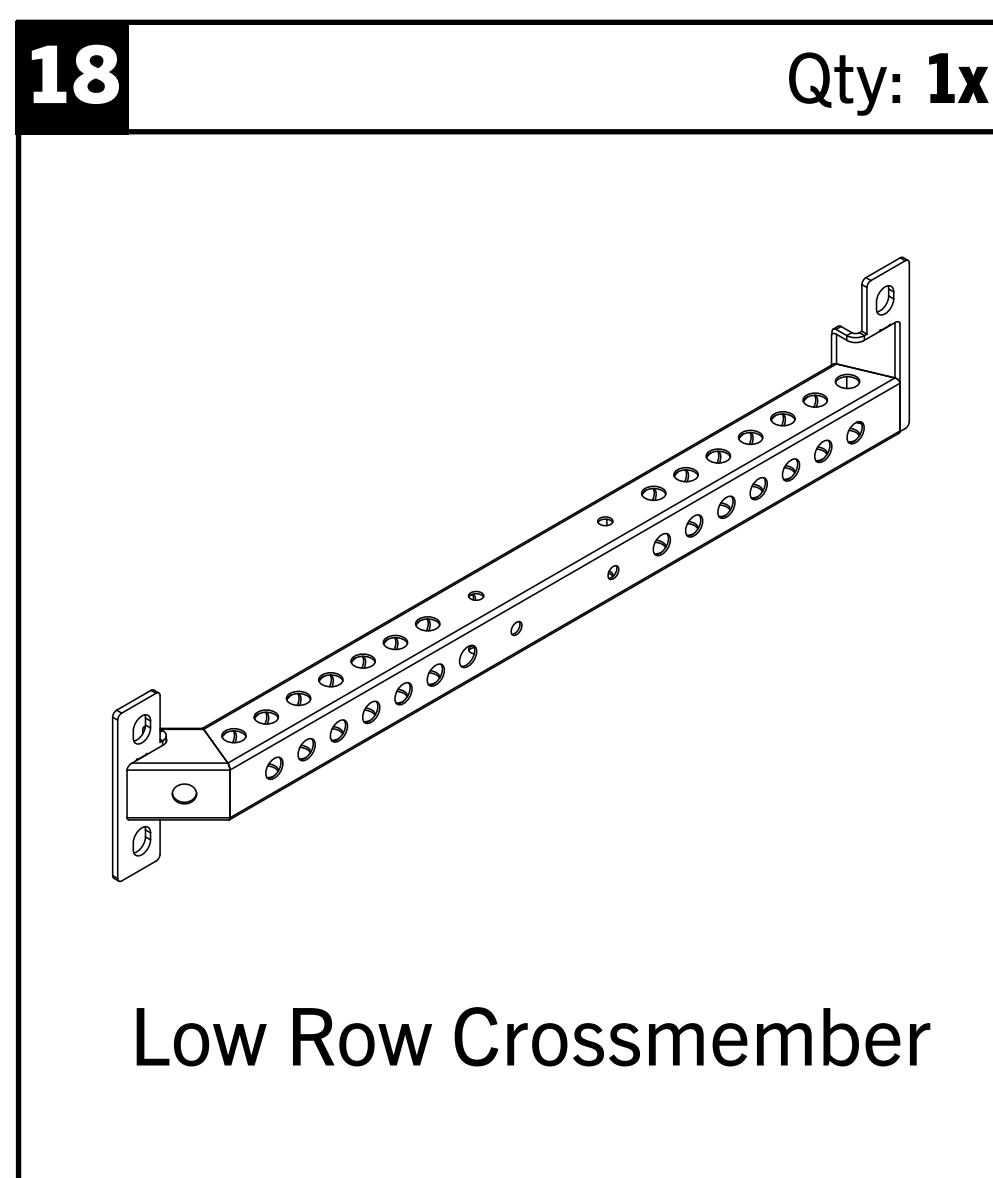

\* Pulley Swivel and Trolley are shown assembled in the parts list but are shipped separately.

# INCLUDED PARTS: FM-6 ADD-ON KIT

Note: Images not shown at scale.

**29** Qty: **4x**



Guide Rod

**30** Qty: **2x**

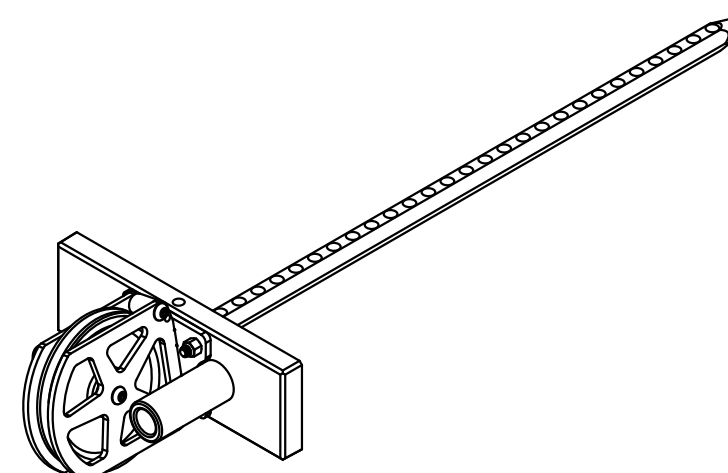

Weight Stack Stem

**31** Qty: **56x**

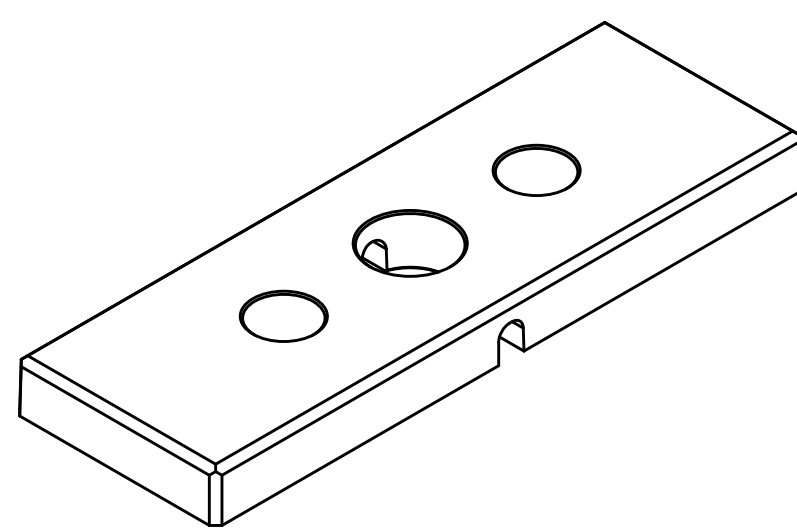

10LB Weight Stack Plate

**32** Qty: **2x**



Weight Stack Selector Pin w/ Lanyard

**33** Qty: **2x**

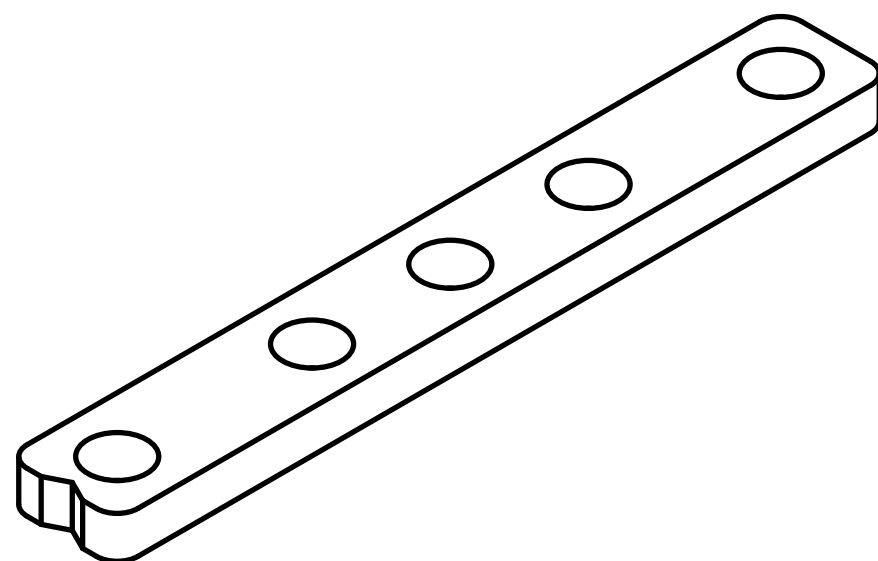

Bottom Weight Stack Spacer

**34** Qty: **2x**

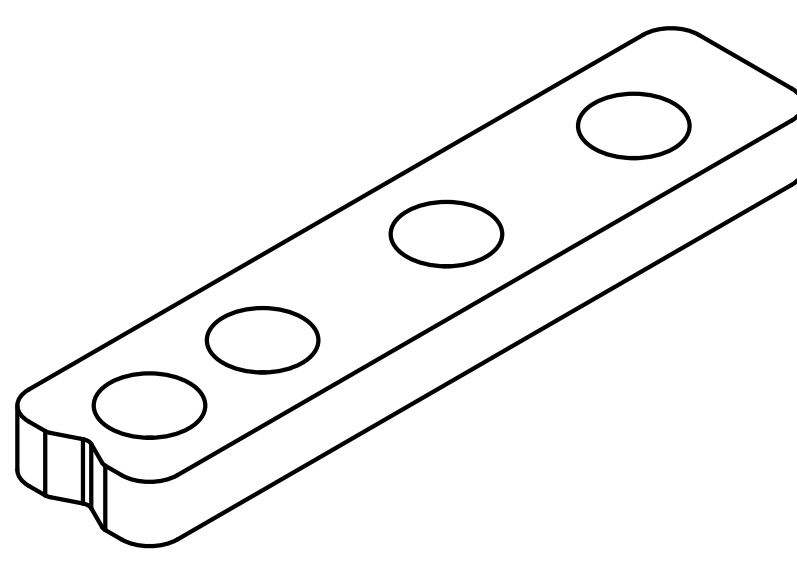

Top Weight Stack Spacer

**35** Qty: **4x**

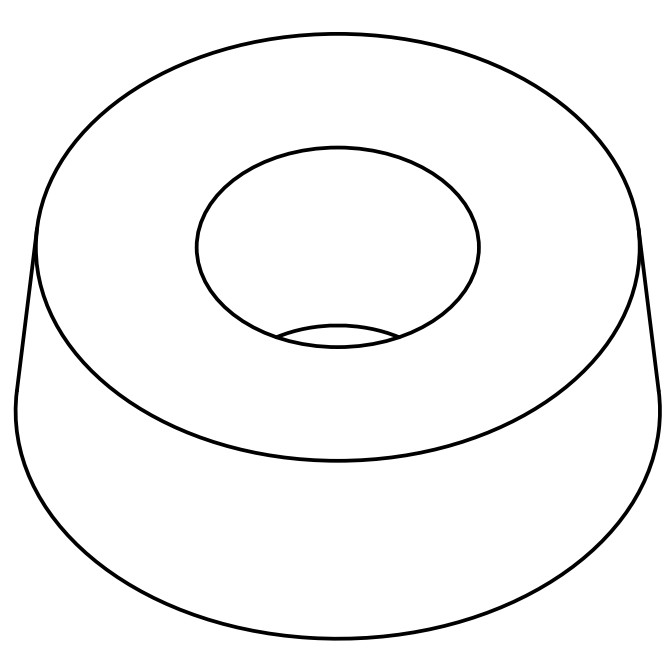

Weight Stack Bottom Bumper

**36** Qty: **2x**

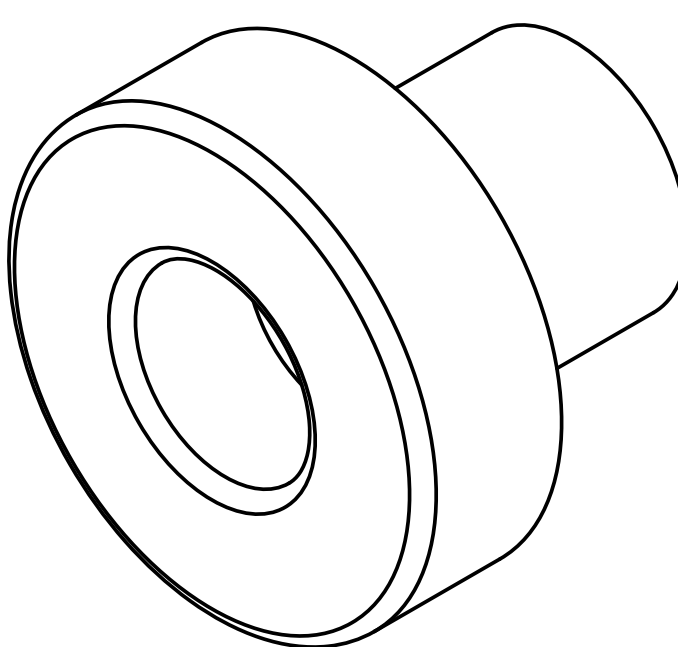

Weight Stack Pulley Top Bumper

**37** Qty: **2x**

\*

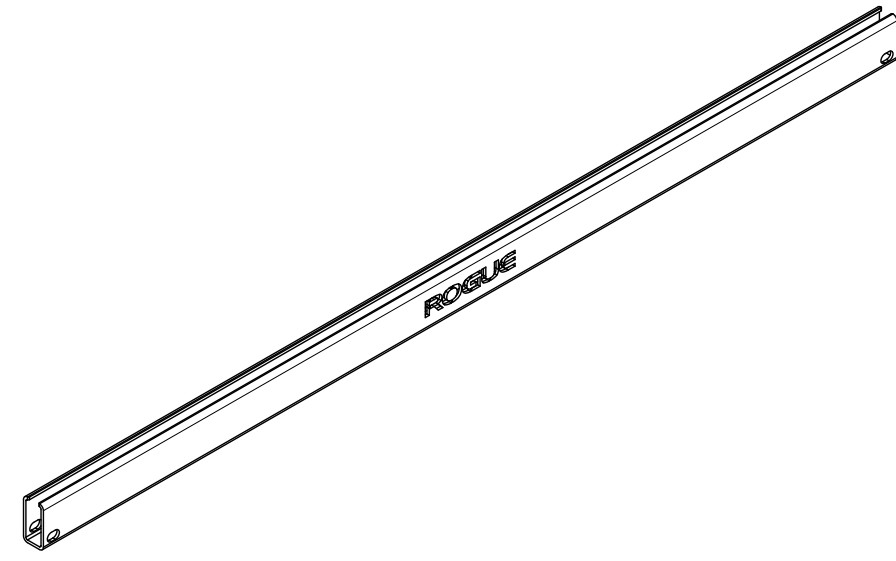

Top Cable Cover Rail (24", 30", or 43")

**38** Qty: **2x**

\*

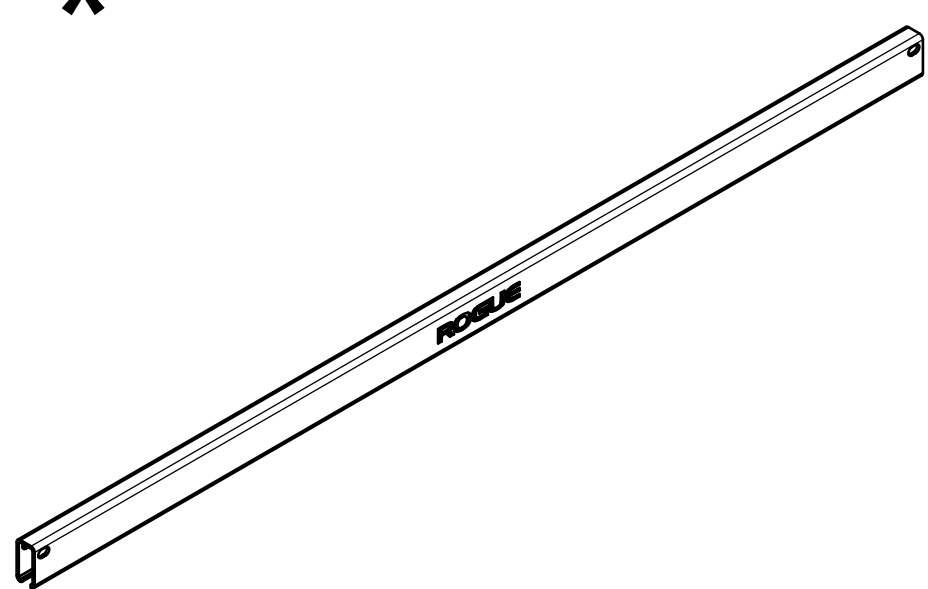

Low Cable Cover Rail (24", 30", or 43")

**39** Qty: **1x**

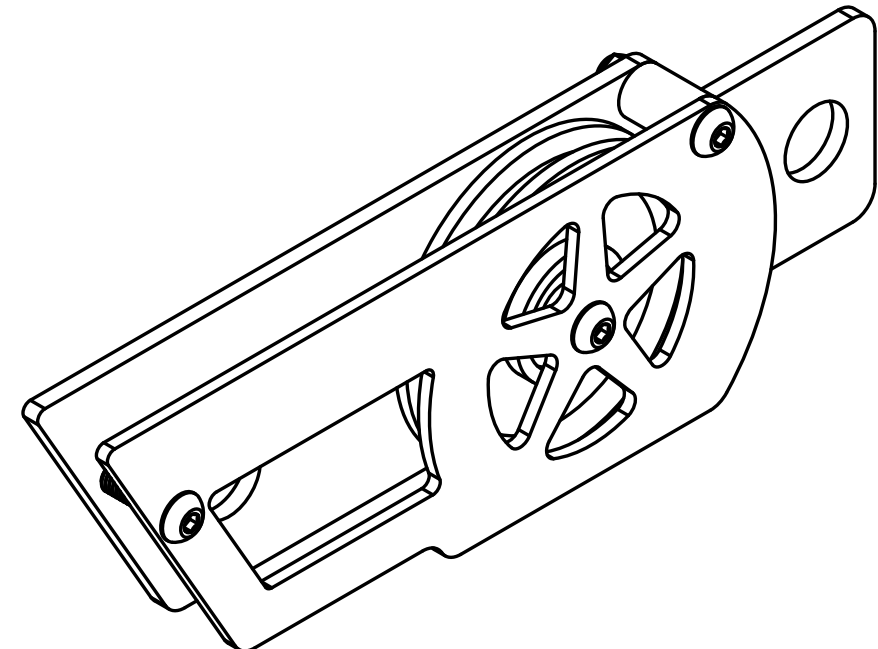

Top Rear Side Pulley Assembly - RH

**40** Qty: **1x**

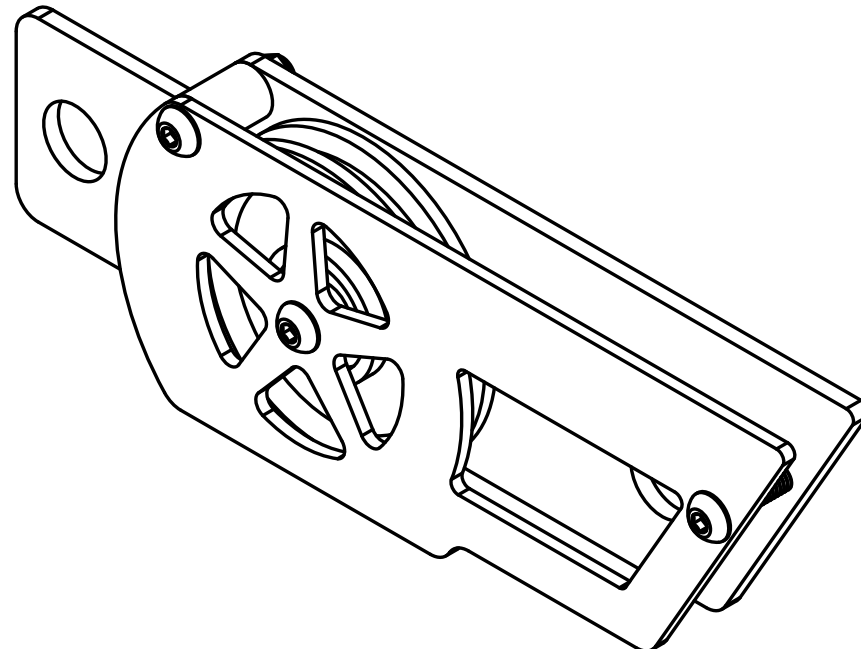

Top Rear Side Pulley Assembly - LH

\* 24", 30", or 43" length depends on rack depth selection made at checkout.

# INCLUDED PARTS: FM-6 ADD-ON KIT

Note: Images not shown at scale.

**41** Qty: **1x**

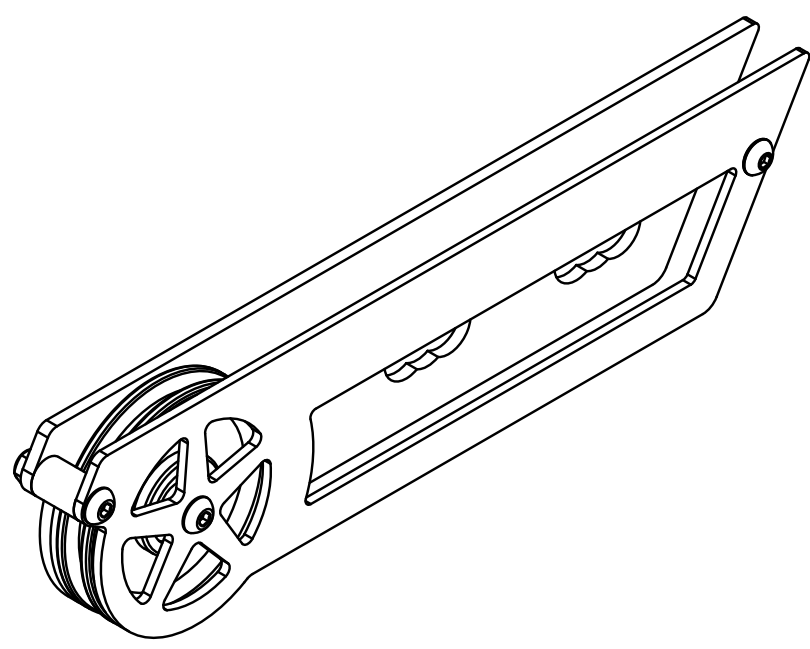

Top Front Side Pulley Assembly - RH

**42** Qty: **1x**

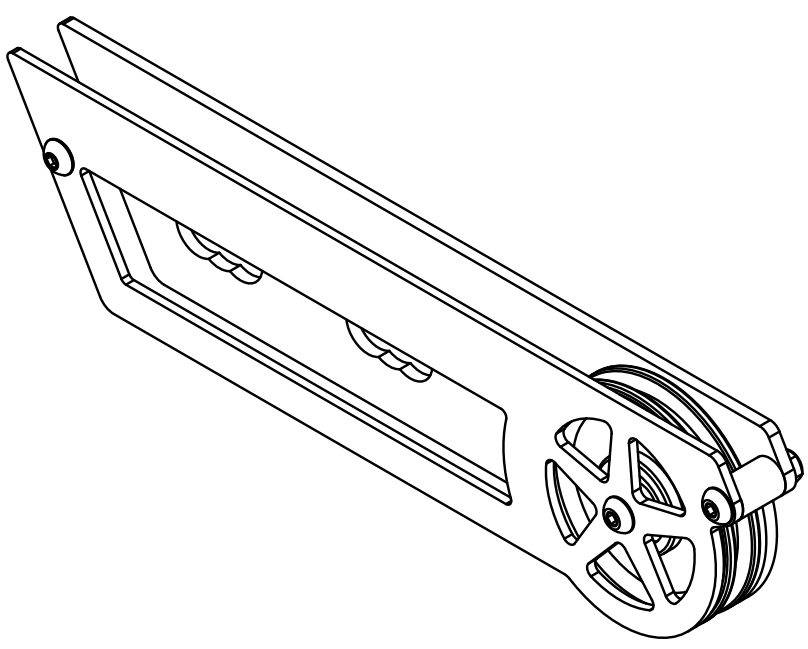

Top Front Side Pulley Assembly - LH

**43** Qty: **1x**

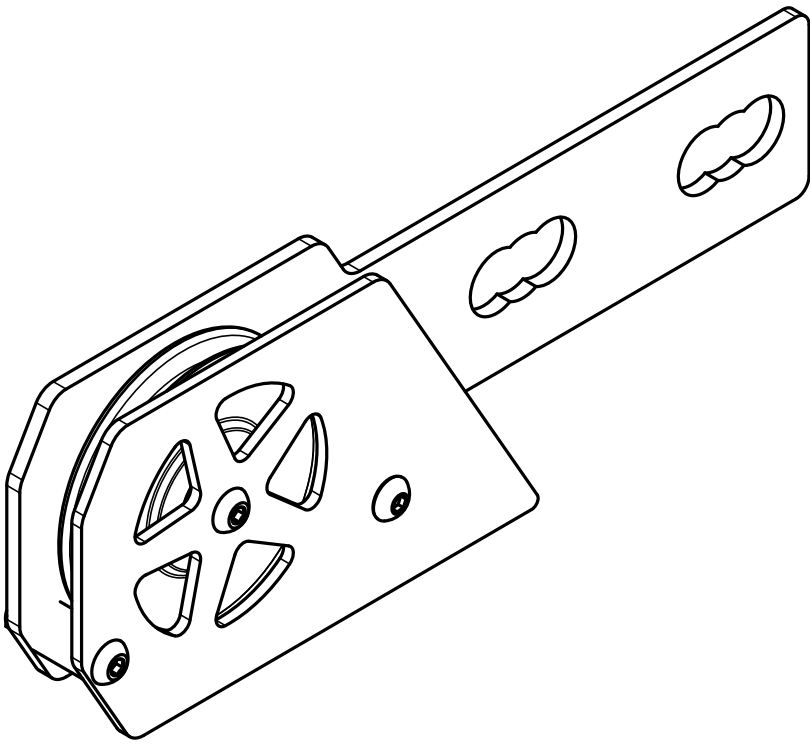

Bottom Front Side Pulley Assembly - RH

**44** Qty: **1x**

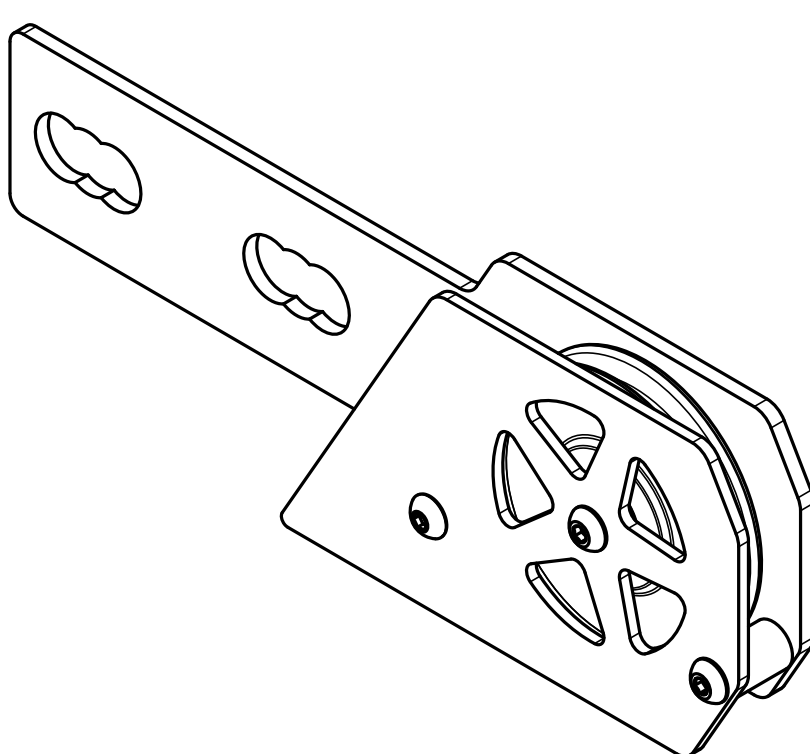

Bottom Front Side Pulley Assembly - LH

**45** Qty: **1x**

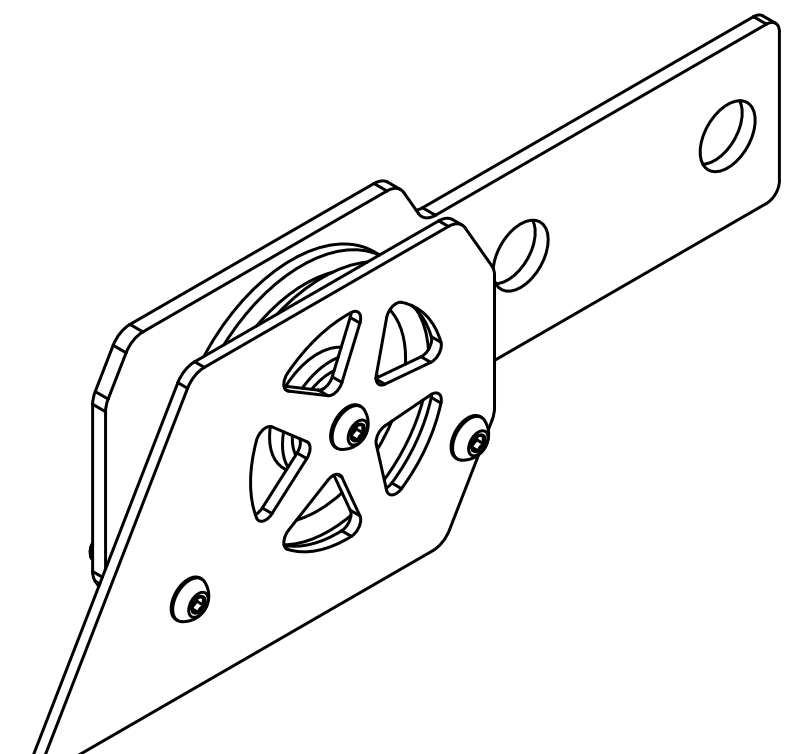

Bottom Rear Side Pulley Assembly - RH

**46** Qty: **1x**

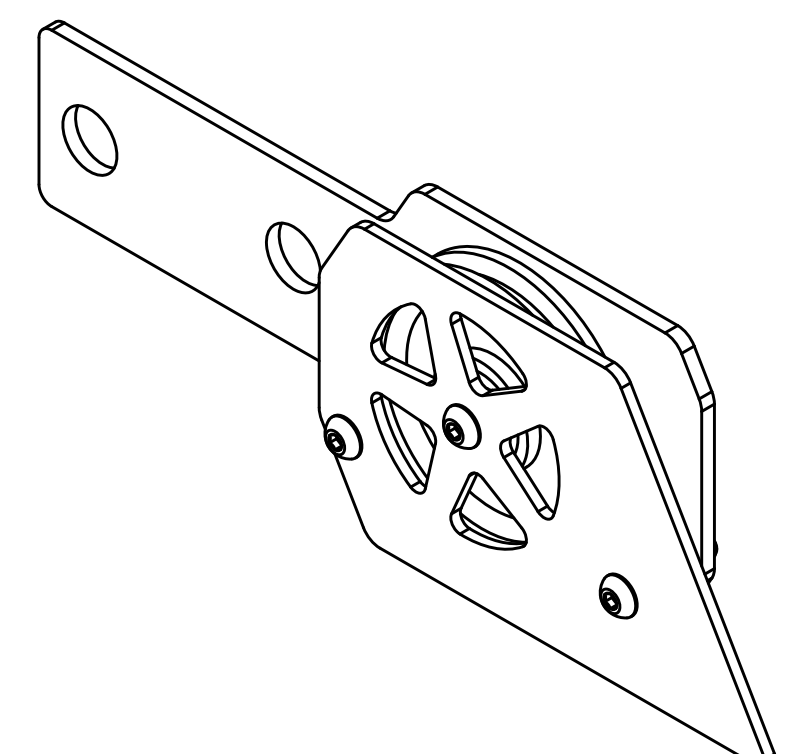

Bottom Rear Side Pulley Assembly - LH

**47** Qty: **1x**

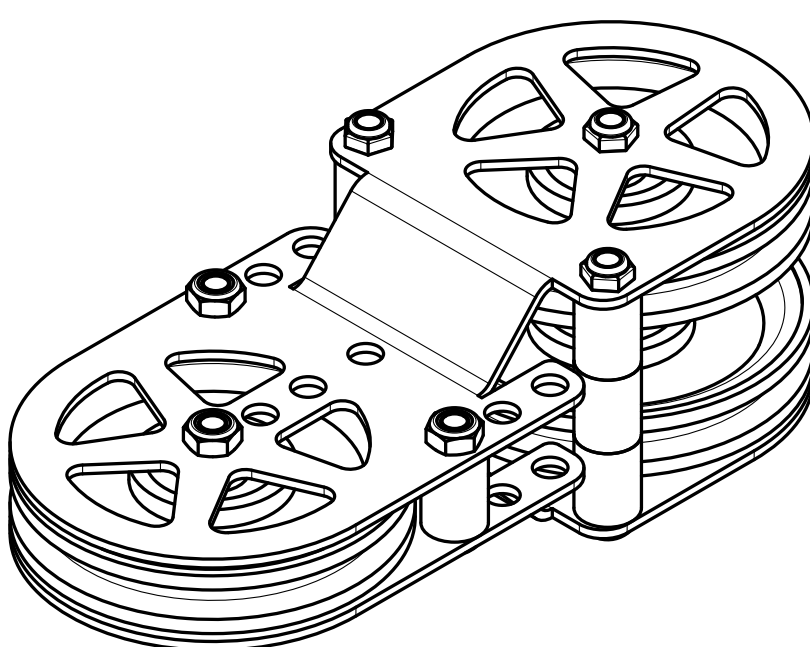

Peanut Pulley

**48** Qty: **1x**

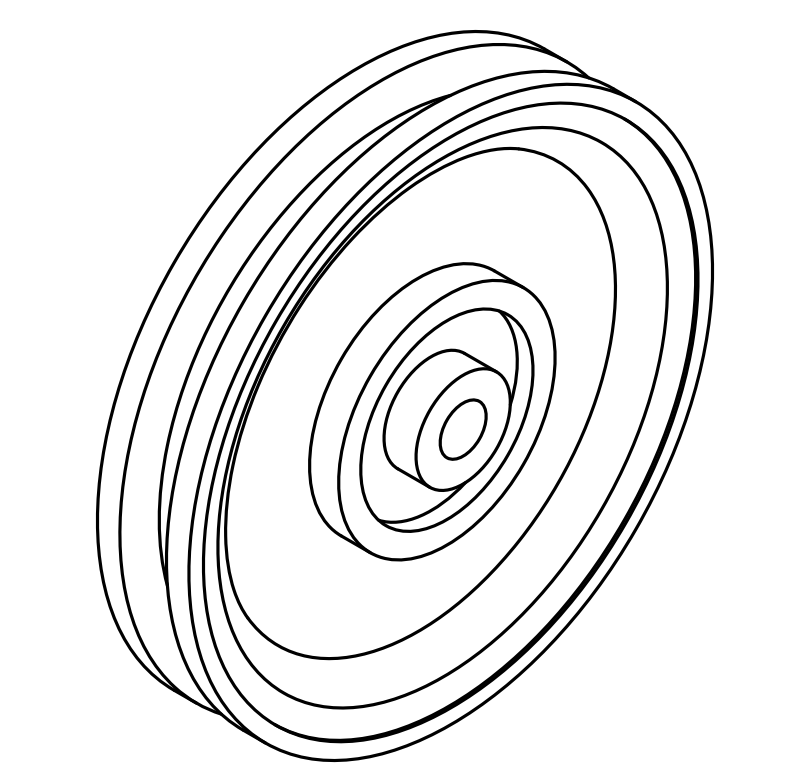

4.5" Pulley

**49** Qty: **1x**

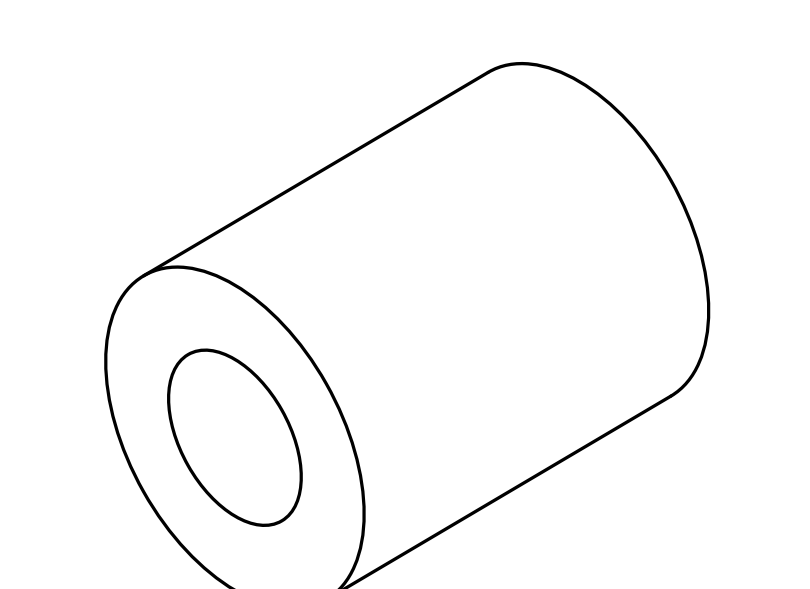

3/4" x 1" Cable Retainer

**50** Qty: **2x**

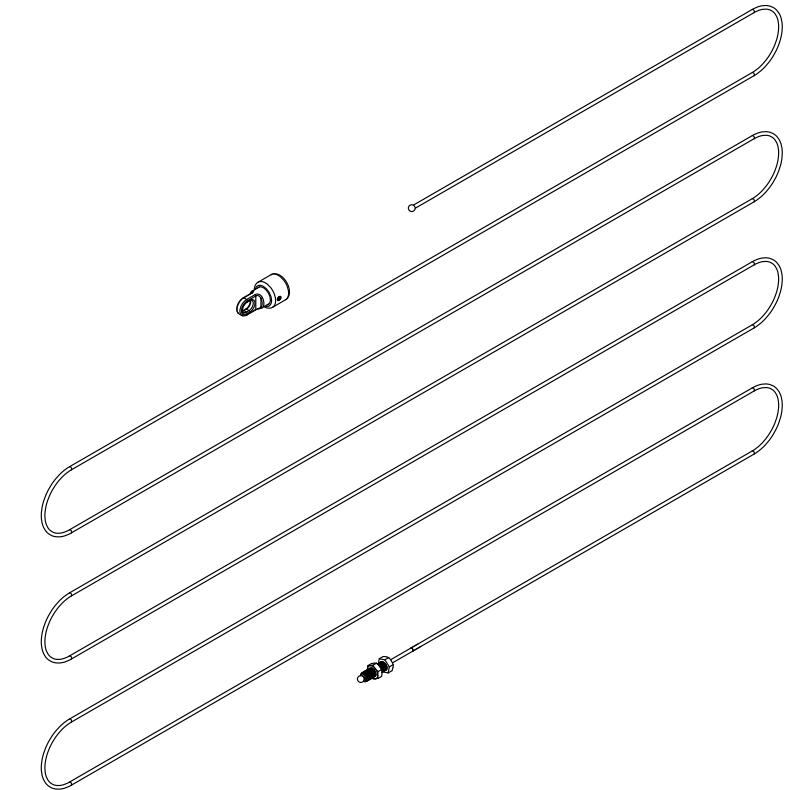

Trolley/Trolley Cable (Blue Tag)

**51** Qty: **1x**

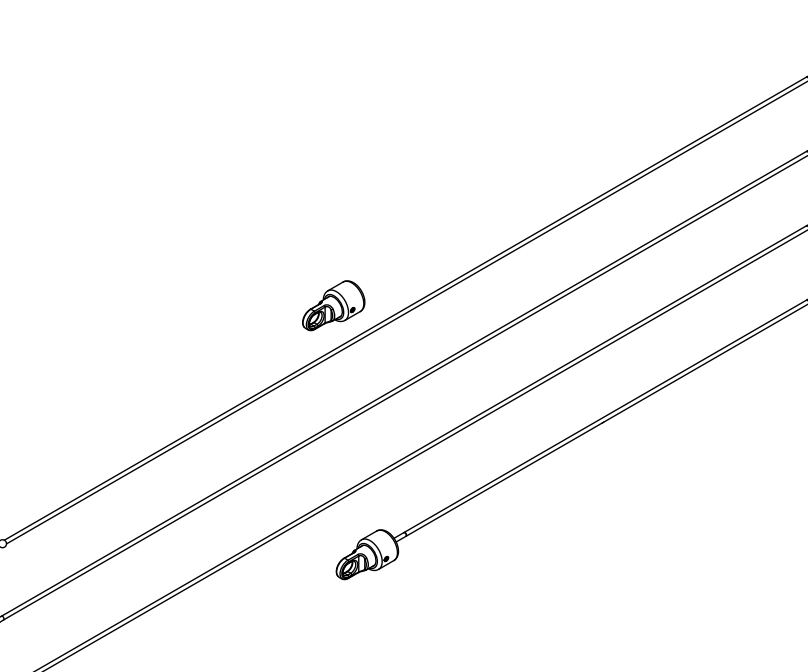

Lat Pull/Low Row Cable (Yellow Tag)

**52** Qty: **2x**

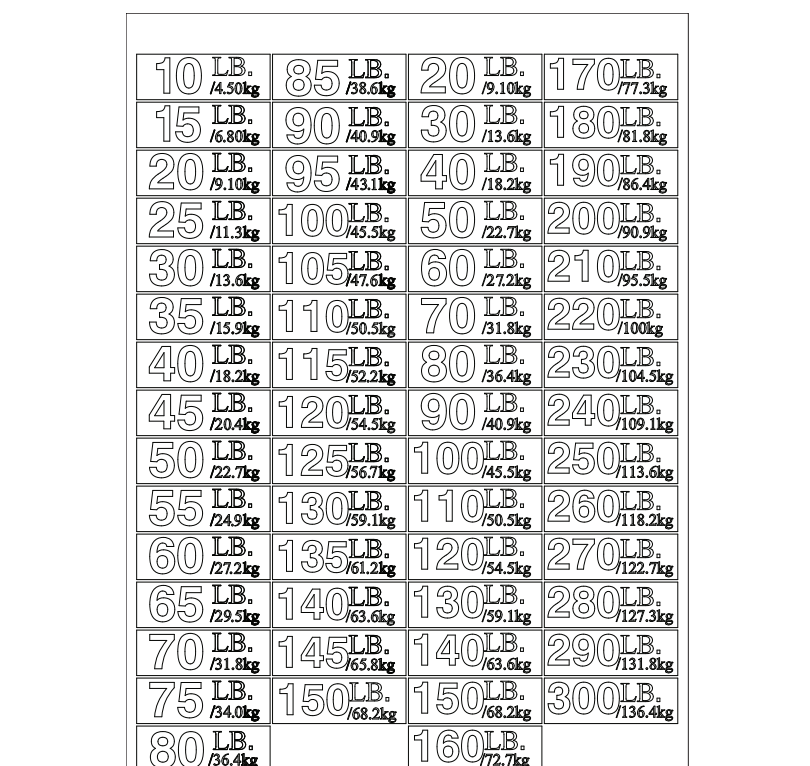

Weight Stack Number Label Sheet

10 LB. 4.50kg	85 LB. 38.6kg	20 LB. 9.10kg	170 LB. 77.3kg
15 LB. 6.80kg	90 LB. 40.9kg	30 LB. 13.6kg	180 LB. 81.6kg
20 LB. 9.10kg	95 LB. 43.1kg	40 LB. 18.2kg	190 LB. 86.4kg
25 LB. 11.3kg	100 LB. 45.5kg	50 LB. 22.7kg	200 LB. 90.9kg
30 LB. 13.6kg	105 LB. 47.6kg	60 LB. 27.2kg	210 LB. 95.3kg
35 LB. 15.9kg	110 LB. 50.0kg	70 LB. 31.8kg	220 LB. 100kg
40 LB. 18.2kg	115 LB. 52.2kg	80 LB. 36.4kg	230 LB. 104.5kg
45 LB. 20.4kg	120 LB. 54.5kg	90 LB. 40.9kg	240 LB. 109.1kg
50 LB. 22.7kg	125 LB. 56.7kg	100 LB. 45.5kg	250 LB. 113.6kg
55 LB. 24.9kg	130 LB. 59.1kg	110 LB. 50.0kg	260 LB. 118.2kg
60 LB. 27.2kg	135 LB. 61.2kg	120 LB. 54.5kg	270 LB. 122.7kg
65 LB. 29.5kg	140 LB. 63.5kg	130 LB. 59.1kg	280 LB. 127.3kg
70 LB. 31.8kg	145 LB. 65.8kg	140 LB. 63.5kg	290 LB. 131.8kg
75 LB. 34.0kg	150 LB. 68.2kg	150 LB. 68.2kg	300 LB. 136.4kg
80 LB. 36.4kg	160 LB. 72.7kg		

# INCLUDED PARTS: FM-6 ADD-ON KIT

Note: Images not shown at scale.

**53** Qty: **8x**

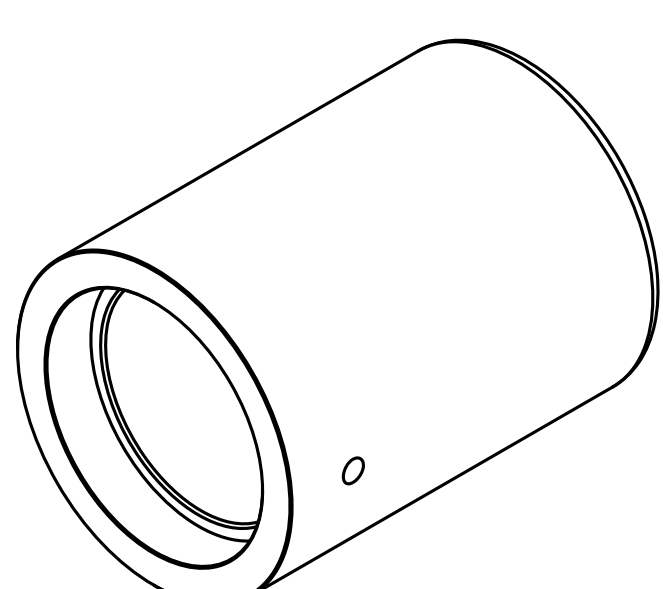
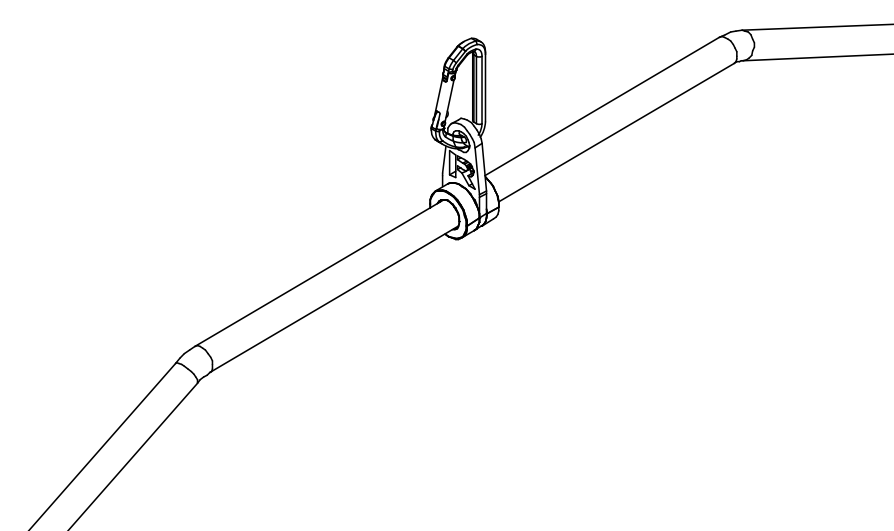

Plate Storage Spacer

**54** Qty: **1x**



Lat Pulldown Bar

**55** Qty: **1x**

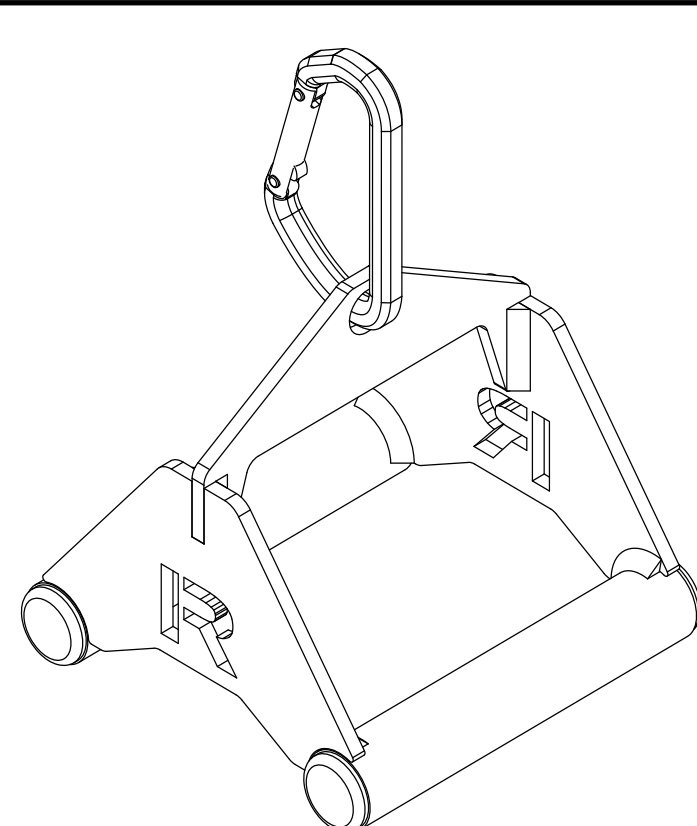

Standard Grip Triangle

**56** Qty: **2x**

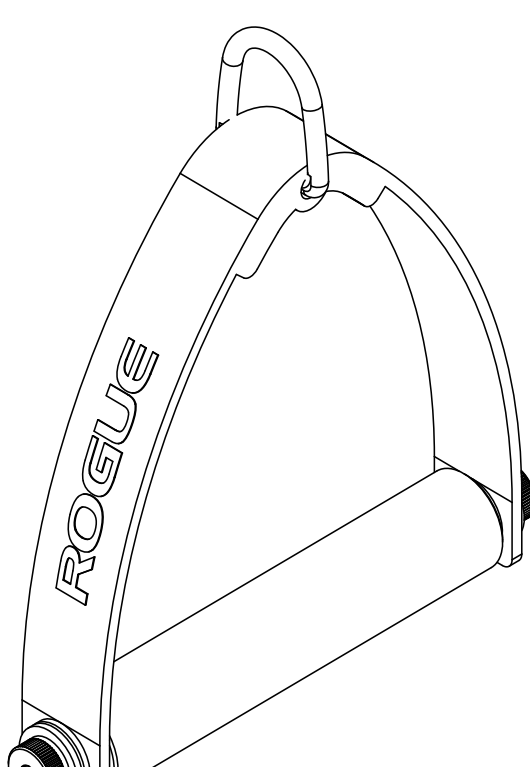

Single Handle Cable Attachment

**57** Qty: **2x**

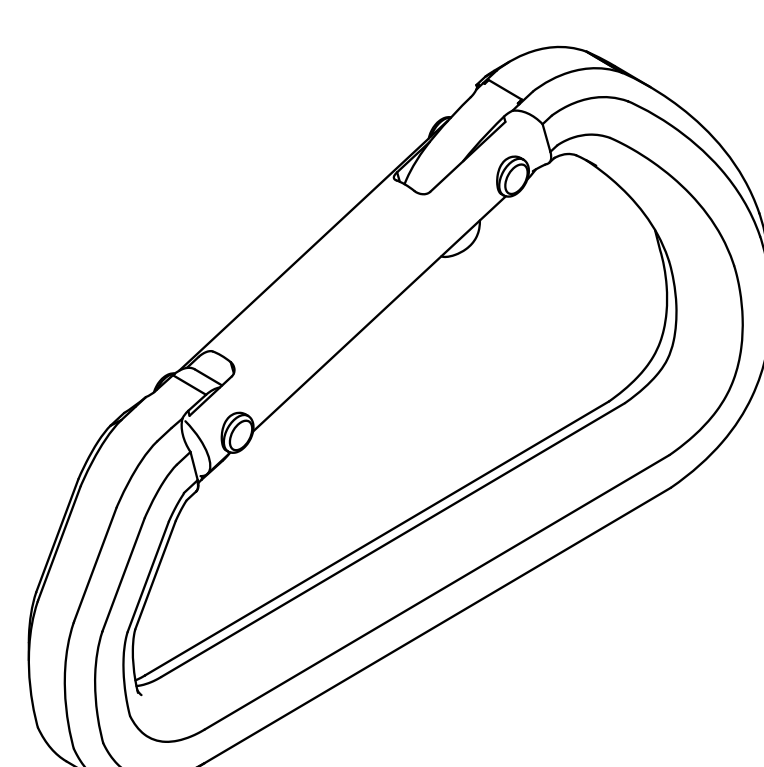

D Carabiner

**58** Qty: **2x**

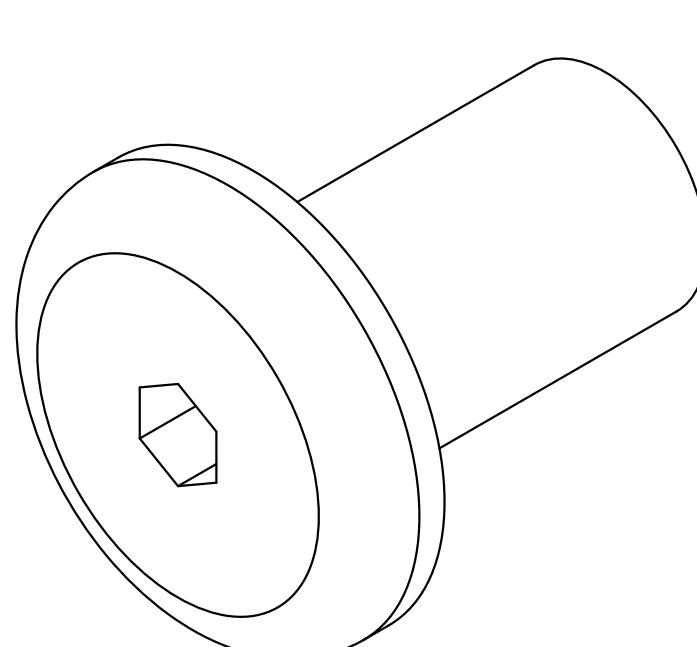

1" Shoulder Bolt - Female

**59** Qty: **2x**

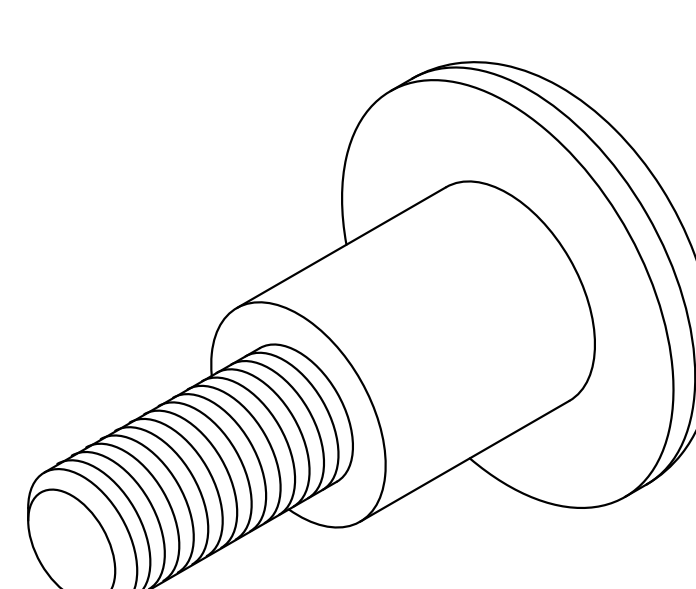

1" Shoulder Bolt - Male

**60** Qty: **22x**

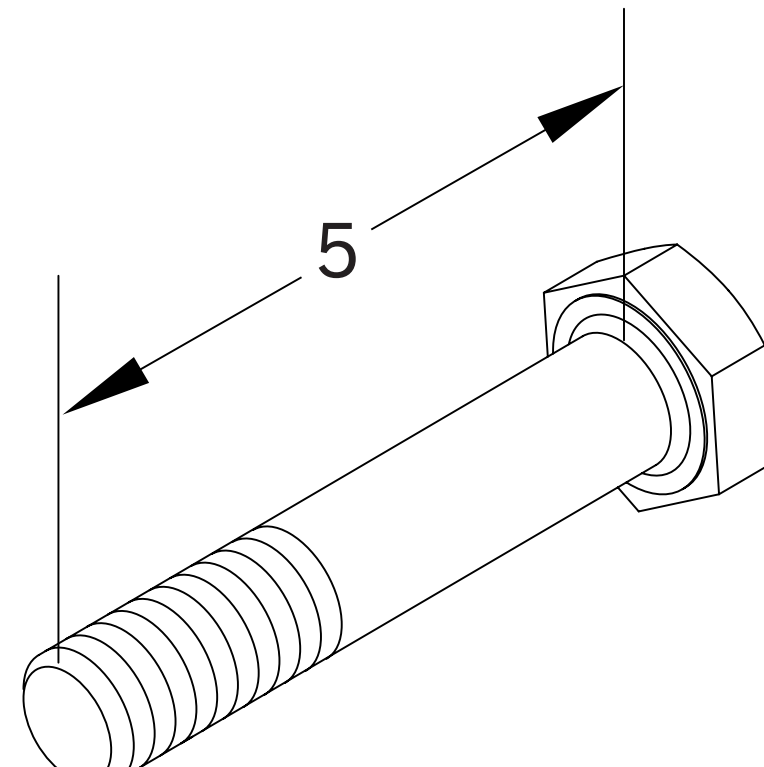

1" x 5" Hex Bolt

**61** Qty: **16x**

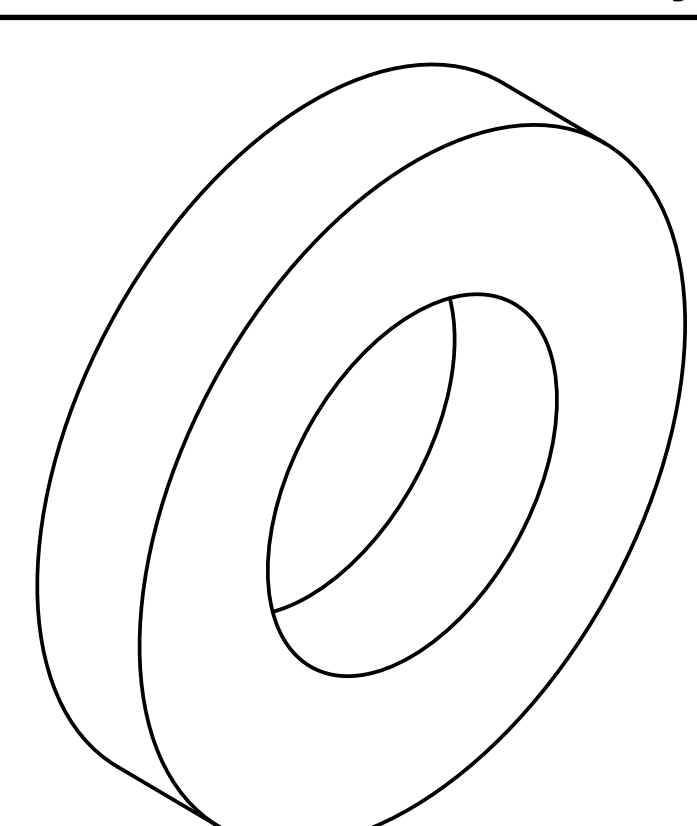

1" x 3/8" Pulley Bracket Spacer

**62** Qty: **18x**

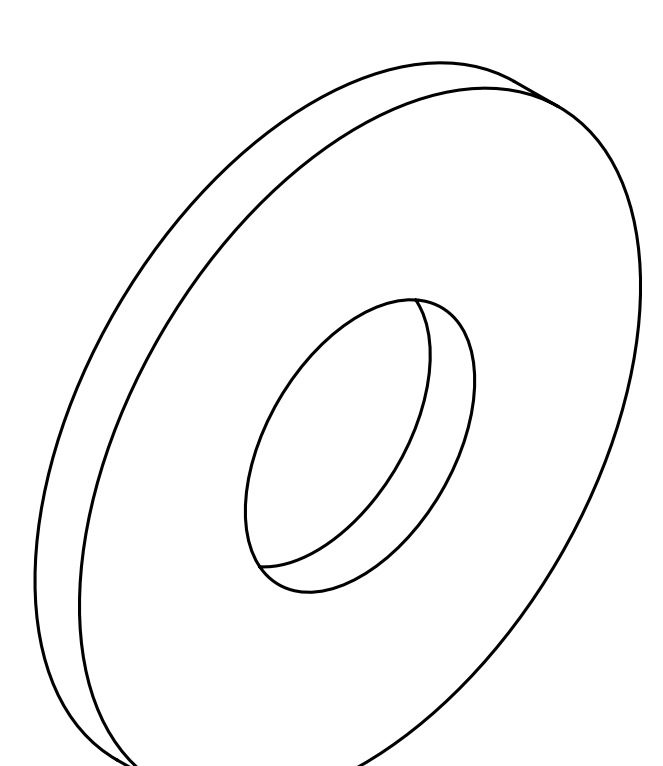

1" Flat Washer

**63** Qty: **22x**

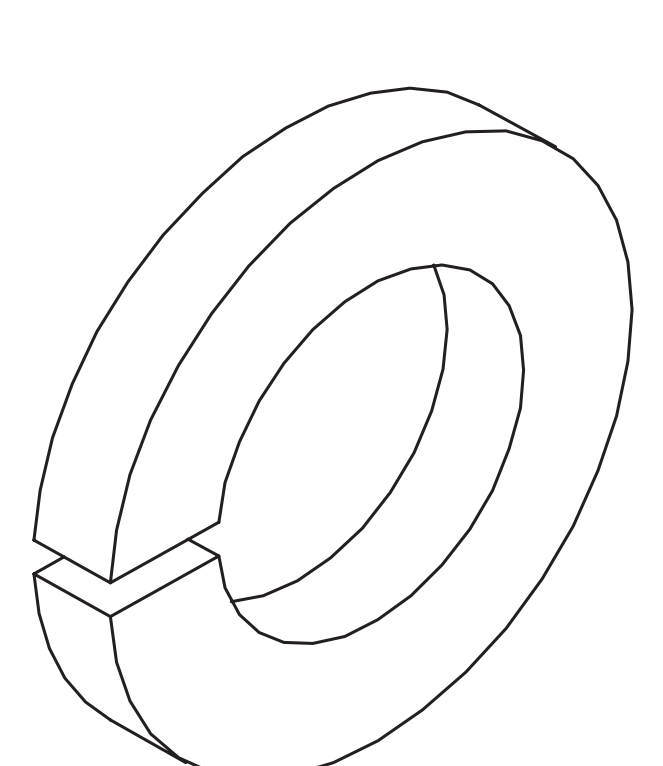

1" Lock Washer

**64** Qty: **22x**

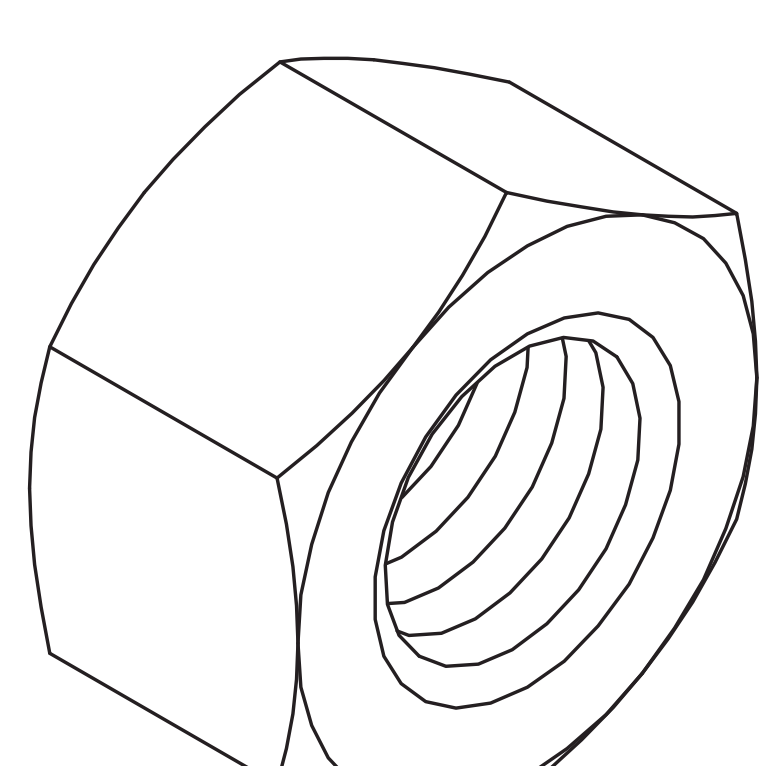

1" Hex Nut

# INCLUDED PARTS: FM-6 ADD-ON KIT

Note: Images not shown at scale.

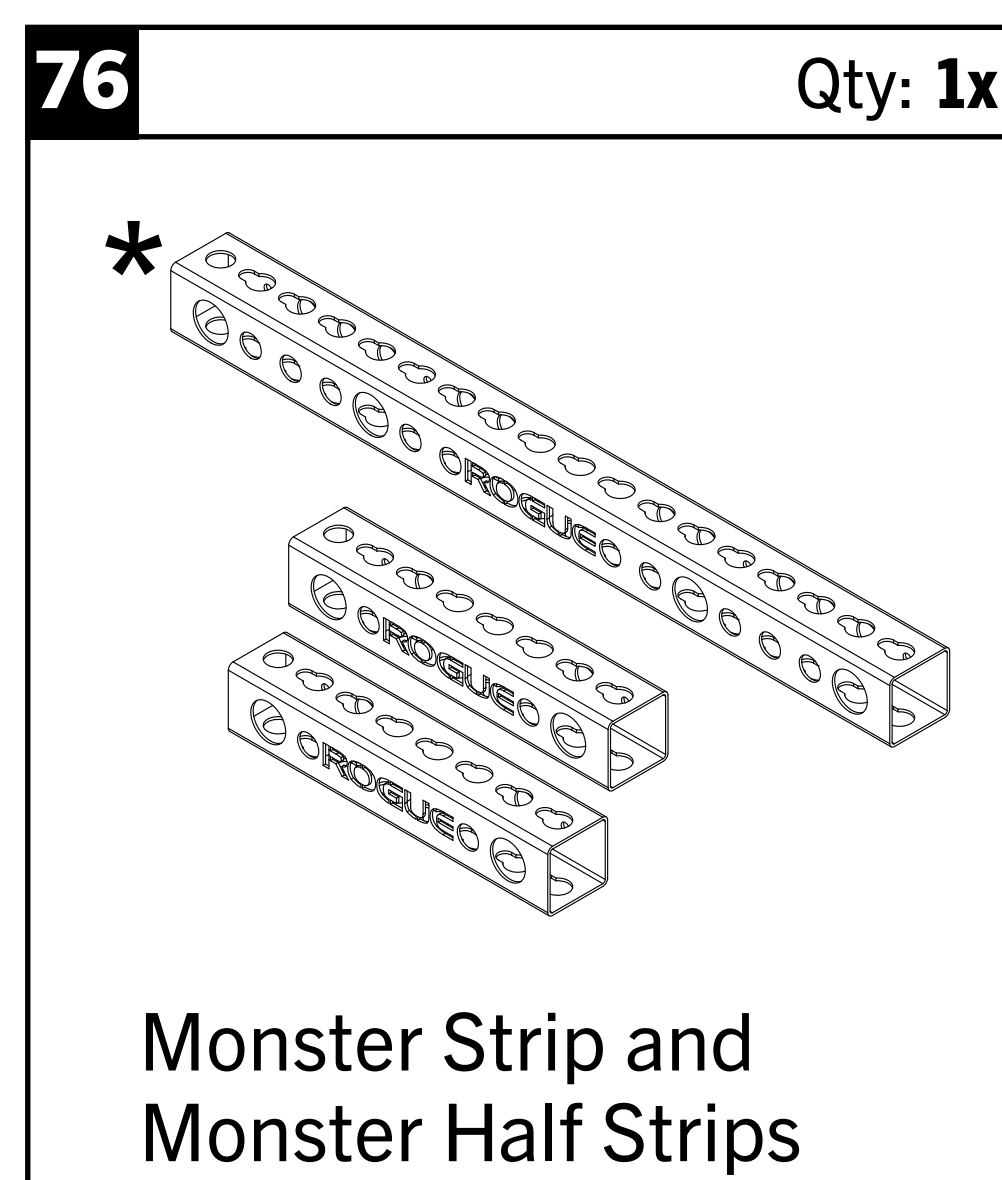
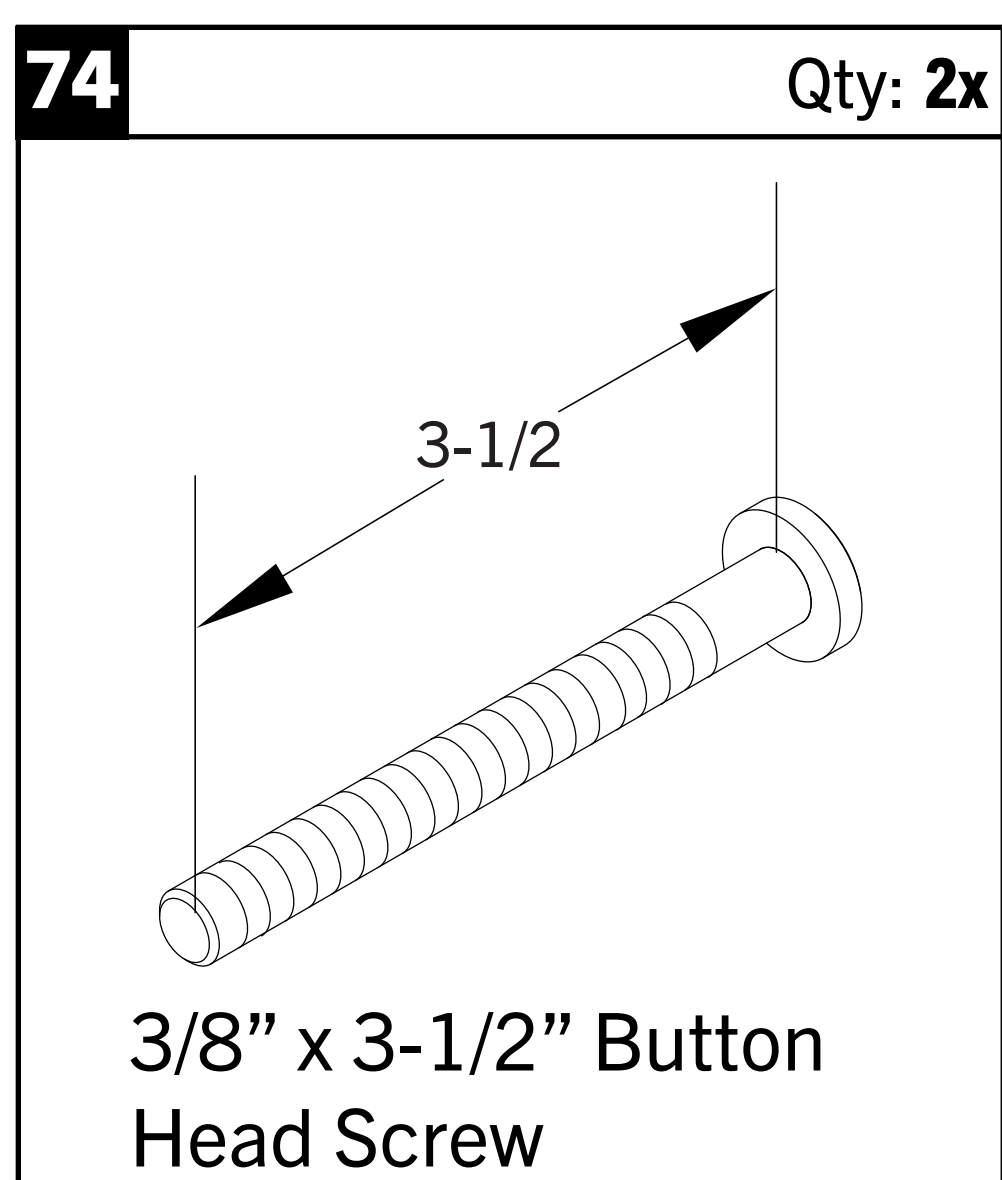
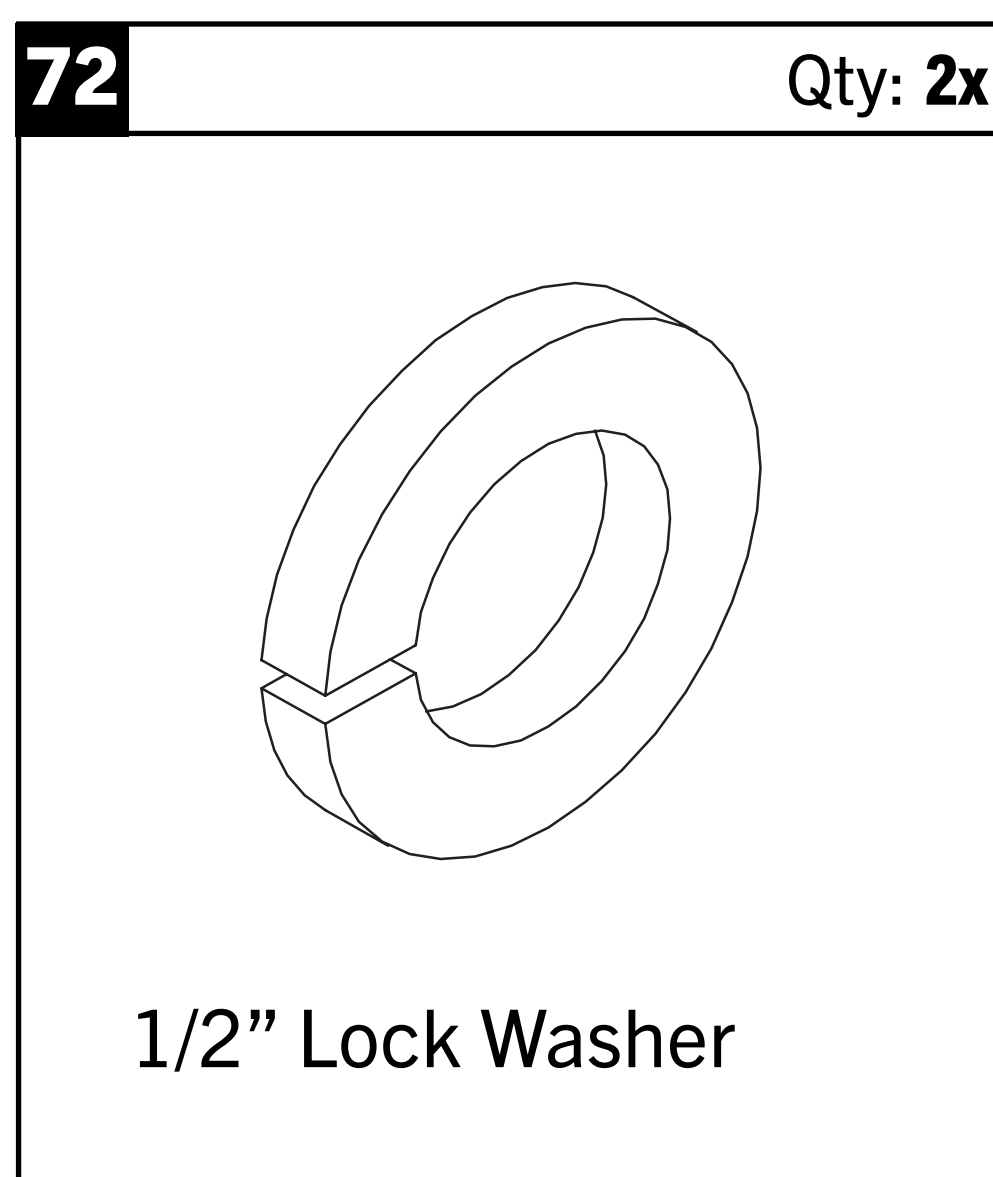
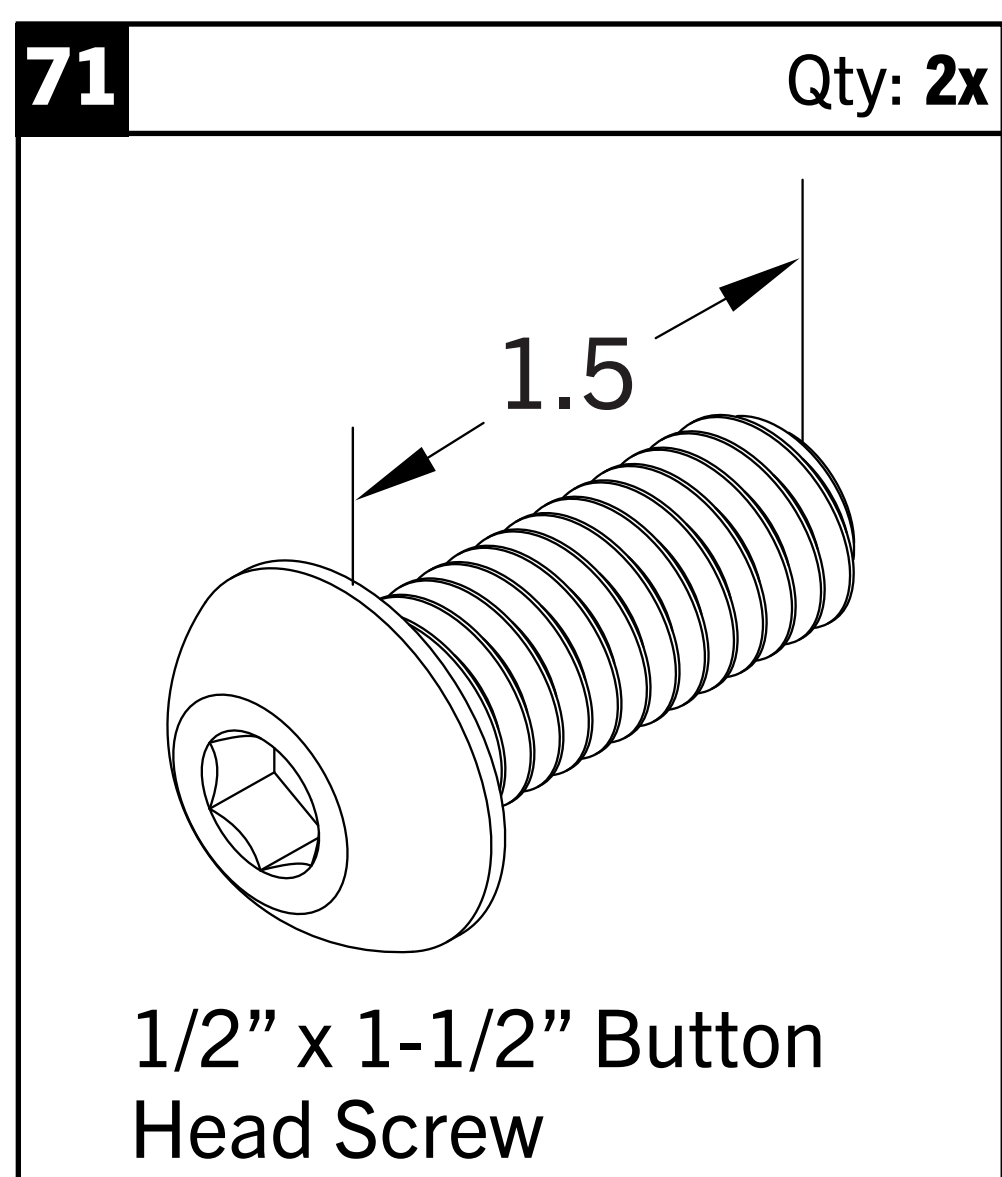
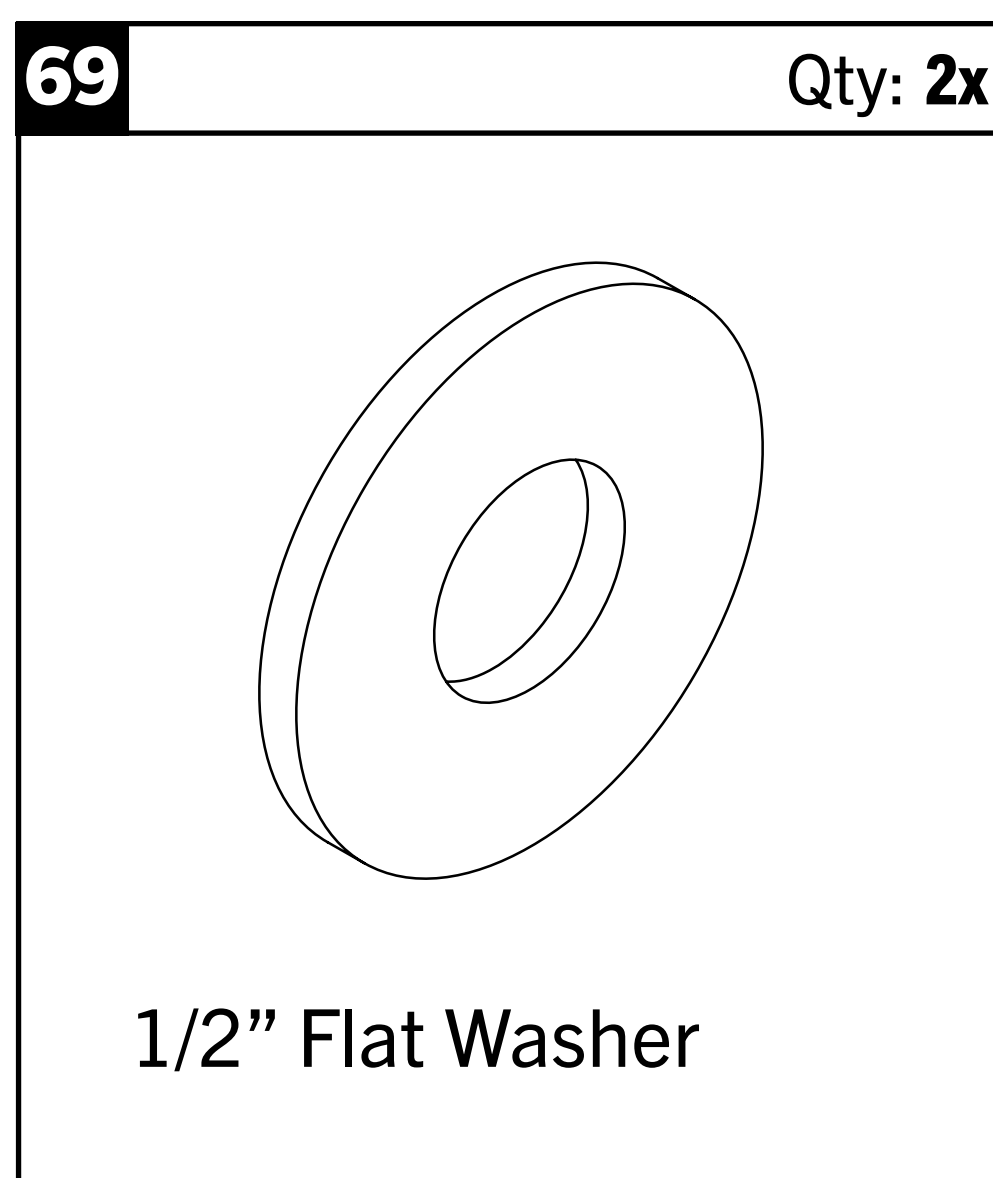
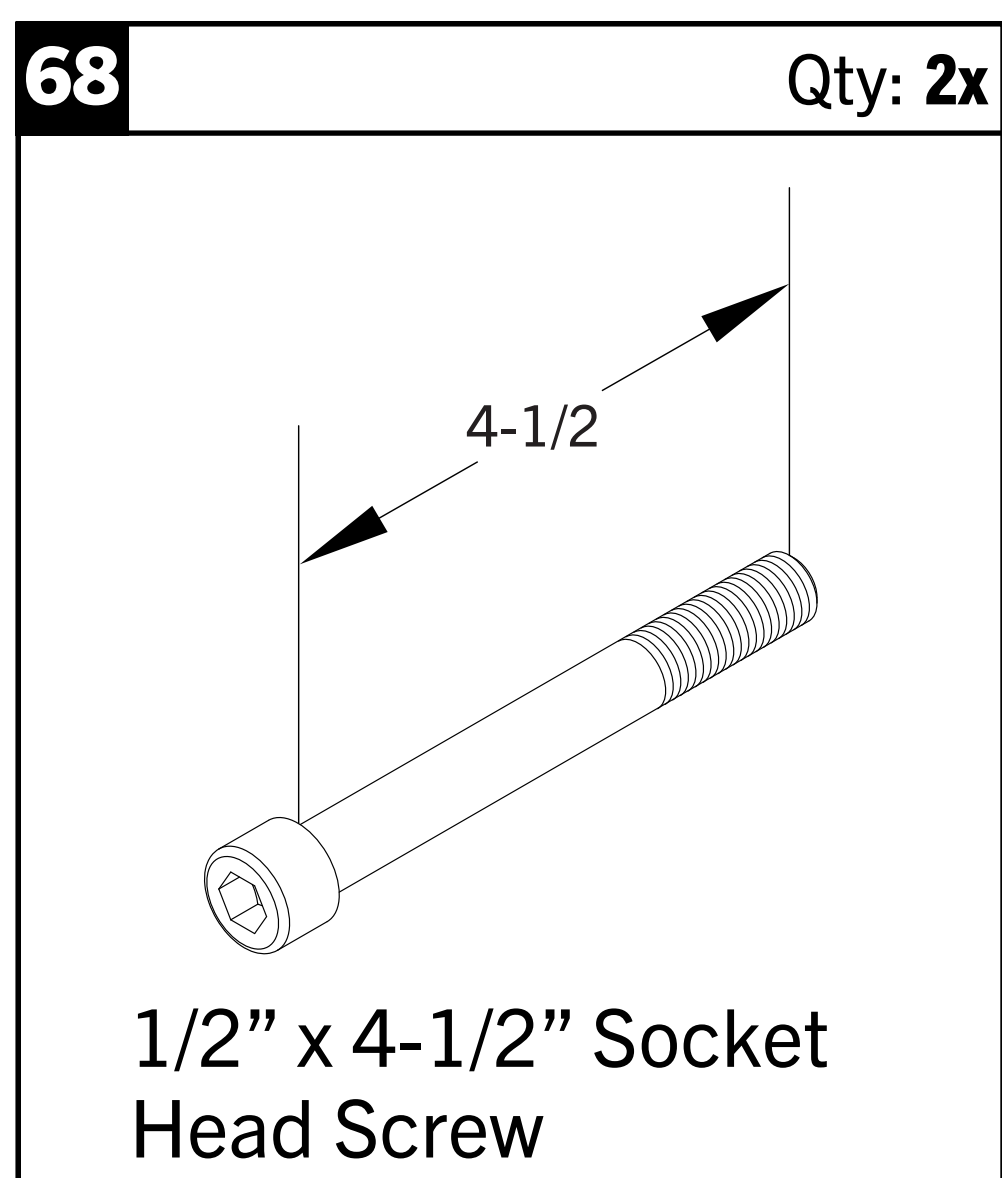
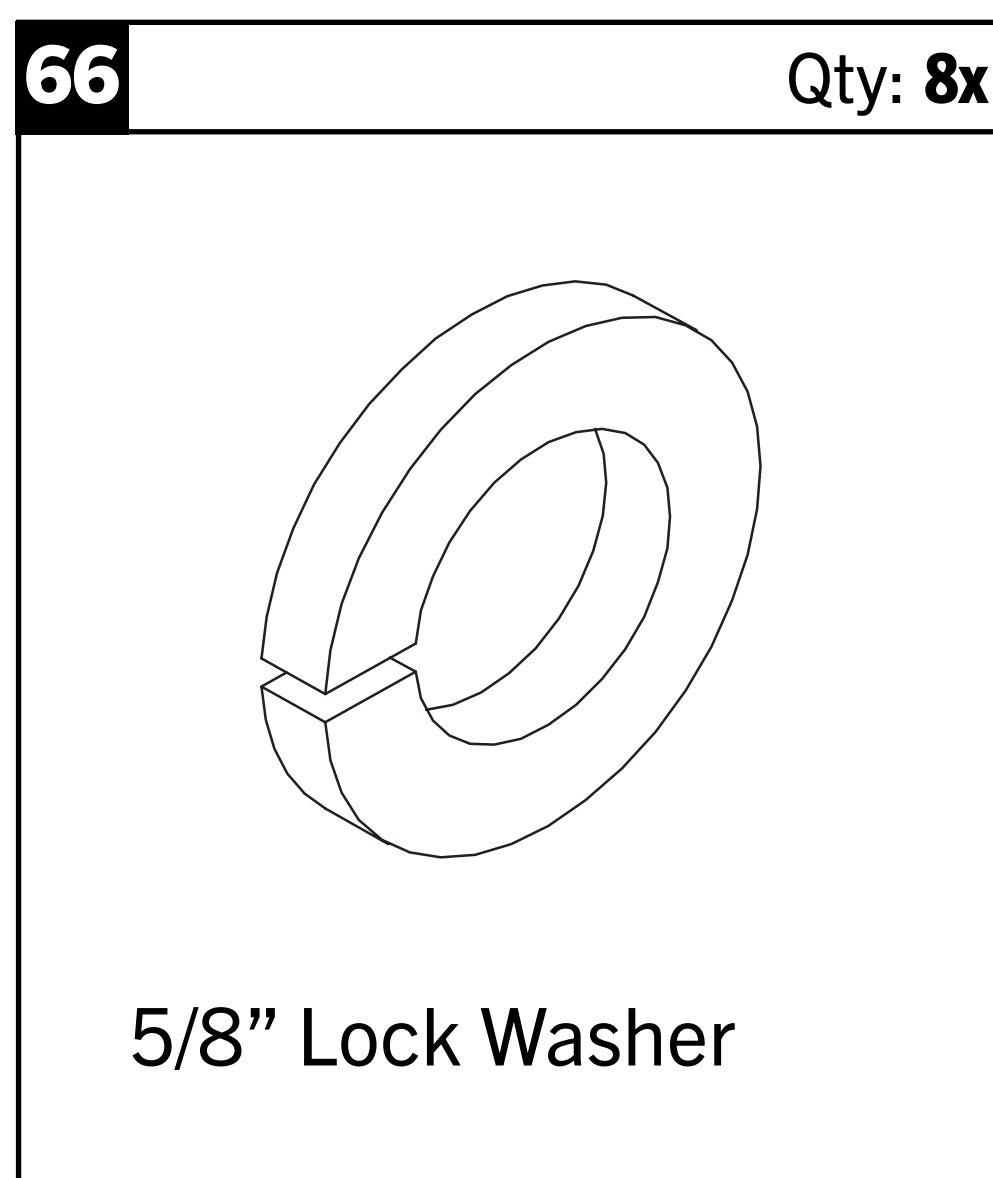
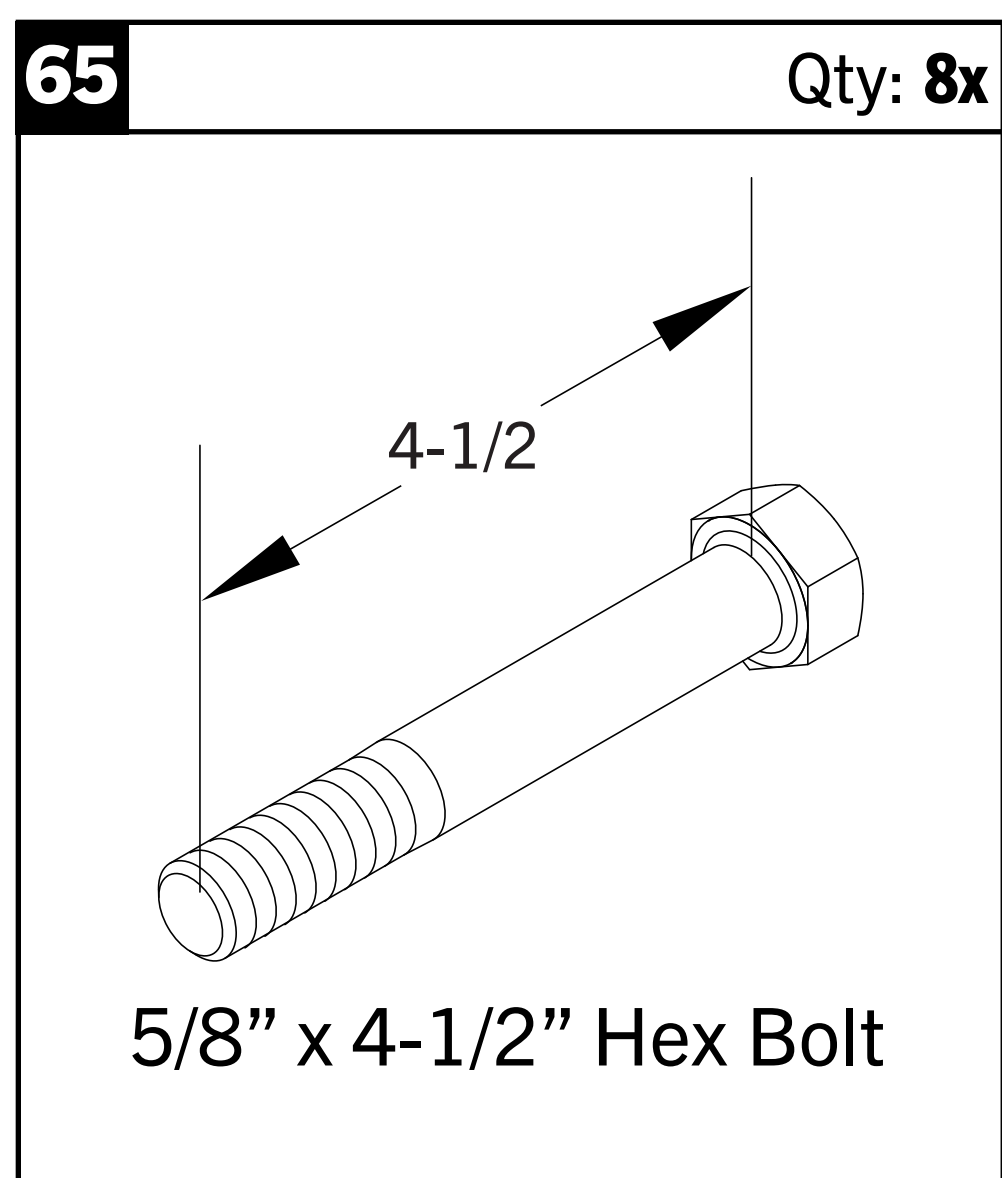

\* Complimentary Monster Strip (1x) and Monster Half Strips (2x) included with hardware kits. See page 49 for Monster Strip and Monster Half Strip assembly.

# INCLUDED PARTS: SHROUD KIT

Note: Images not shown at scale.

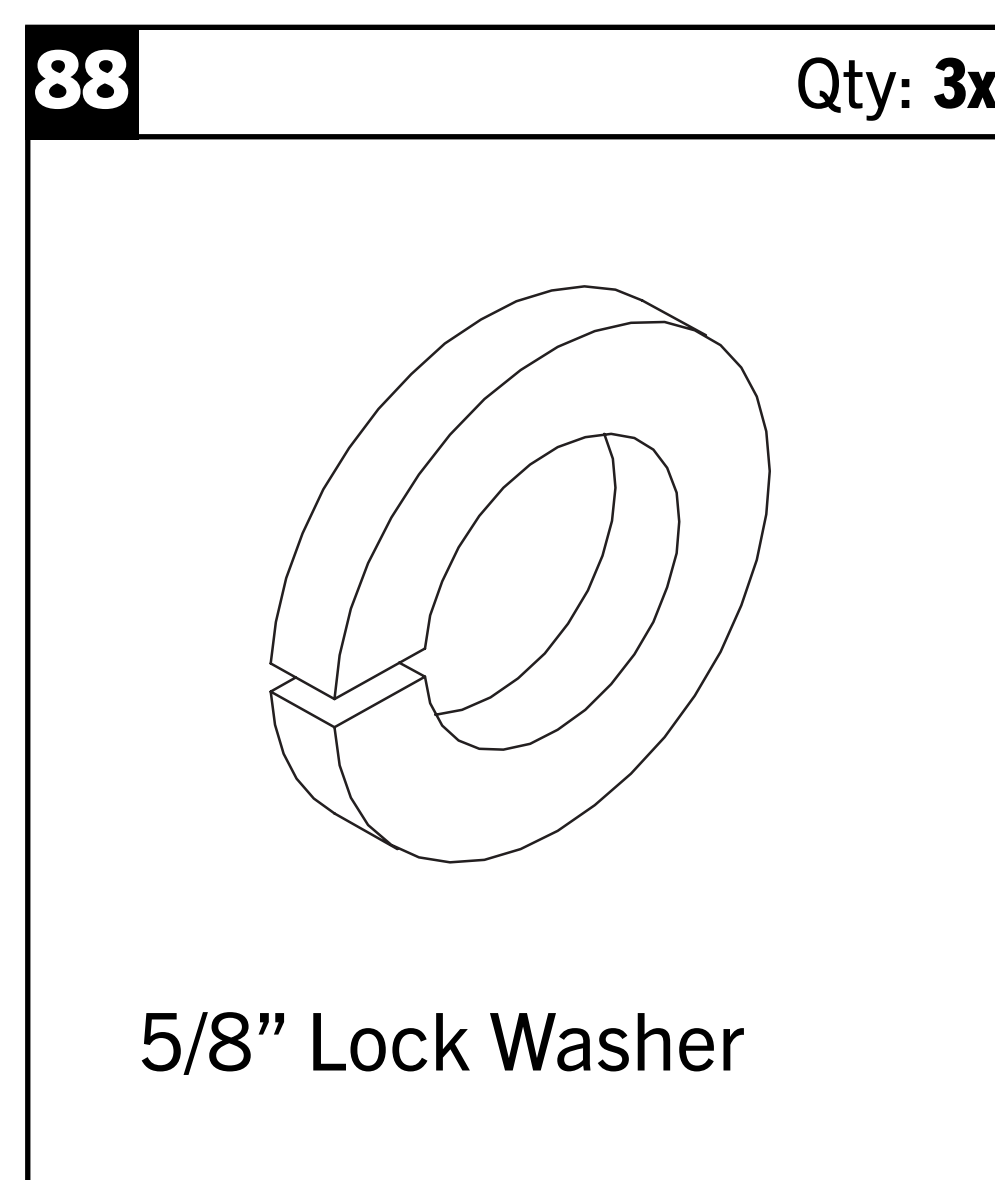
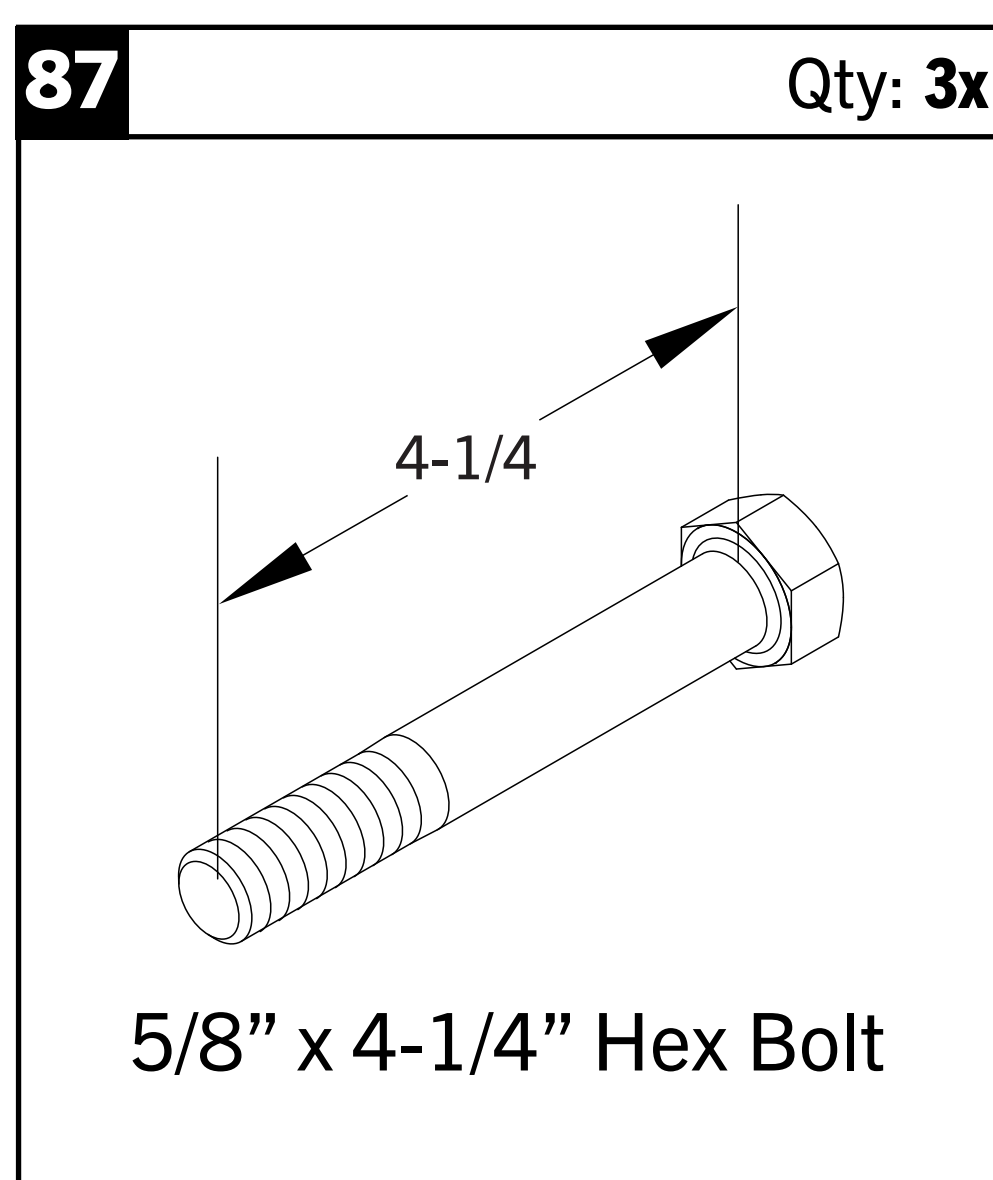
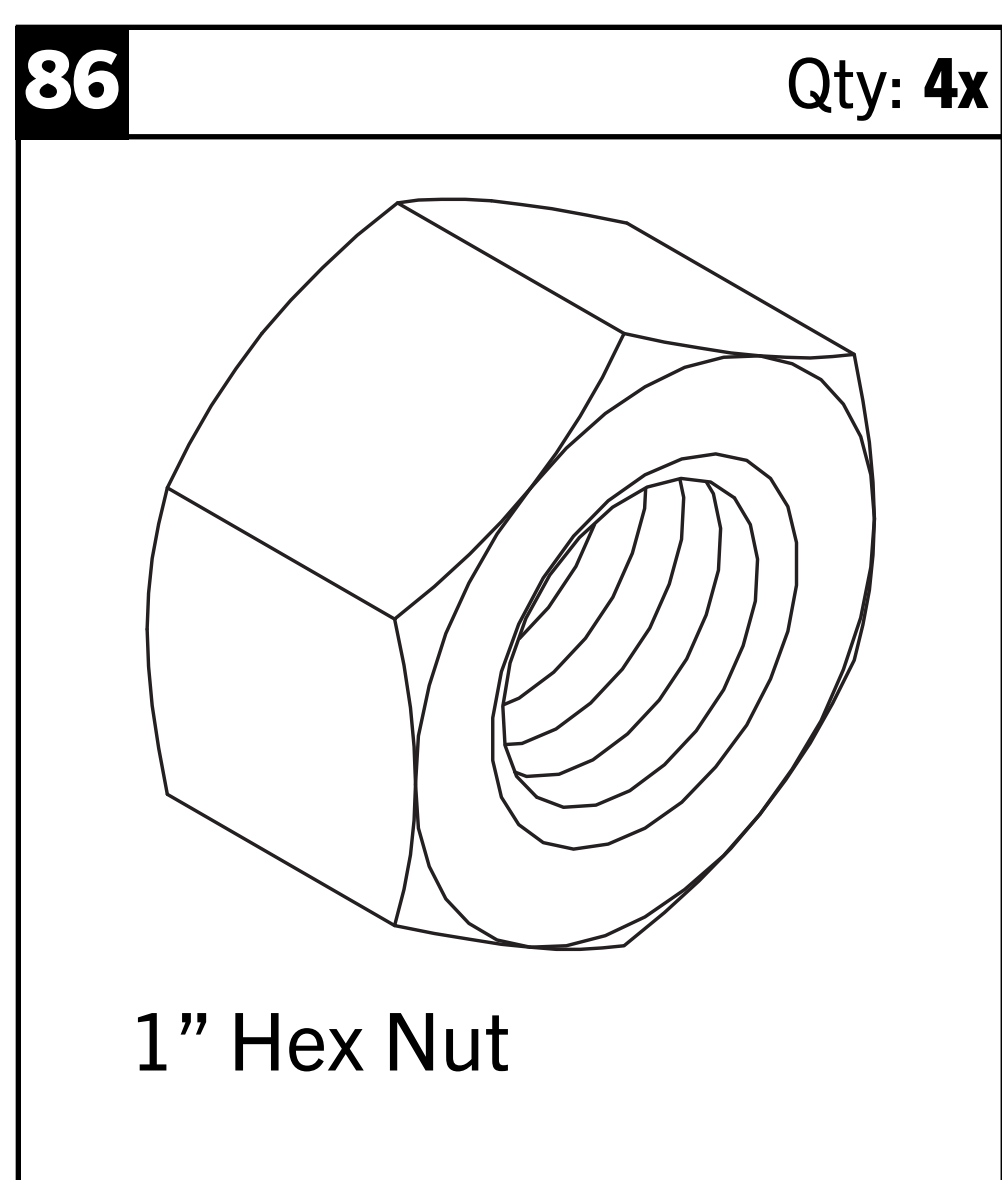
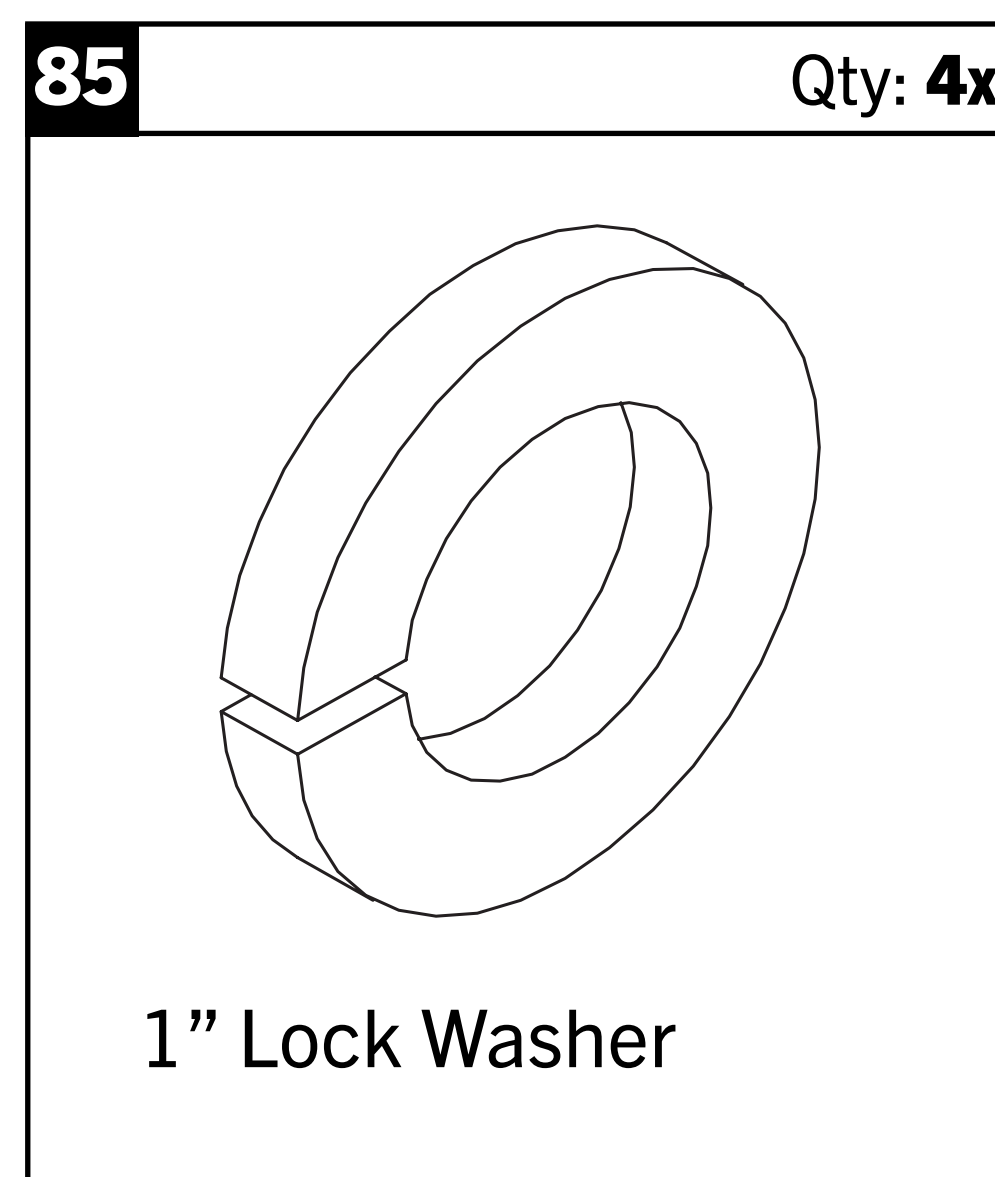
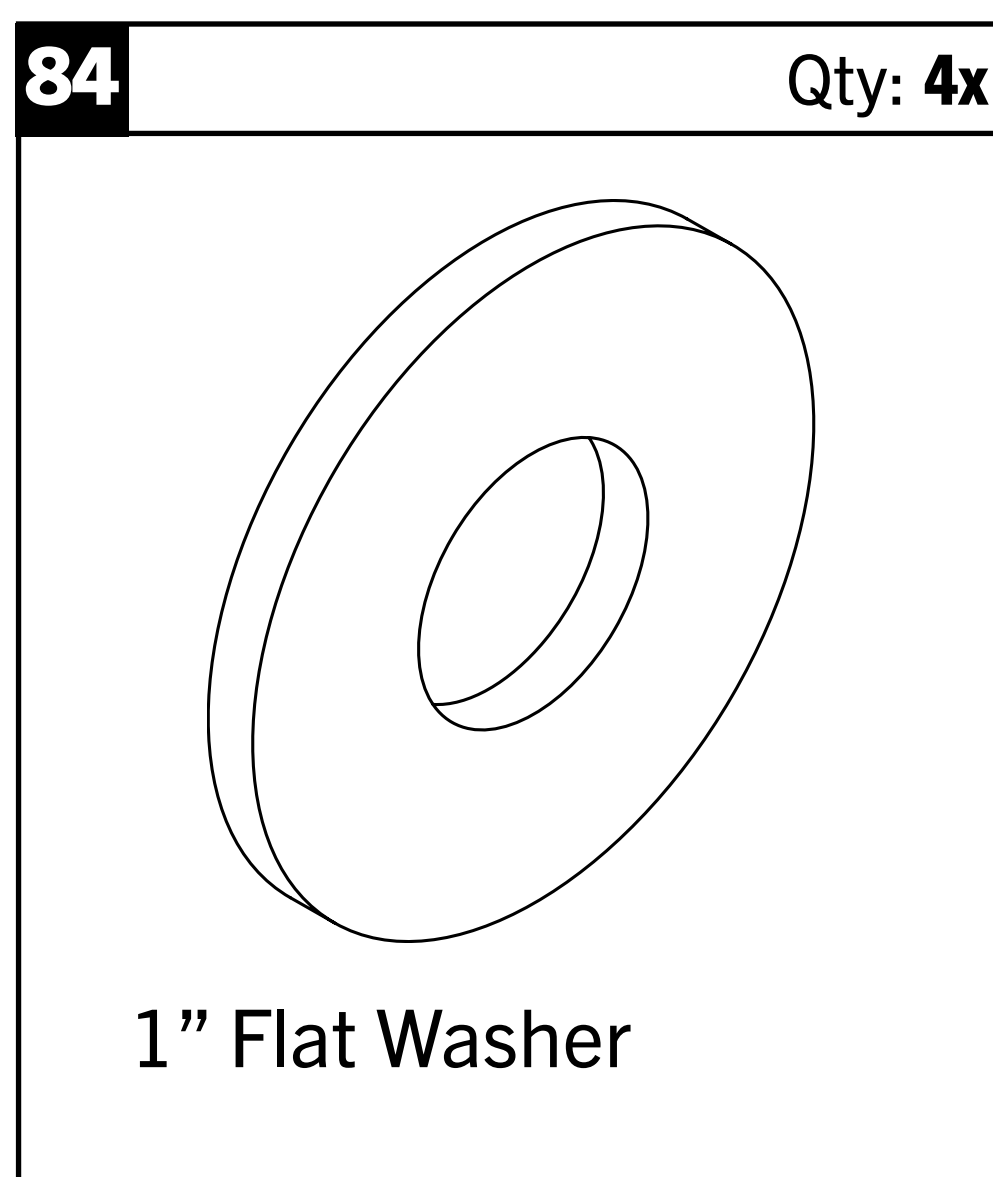
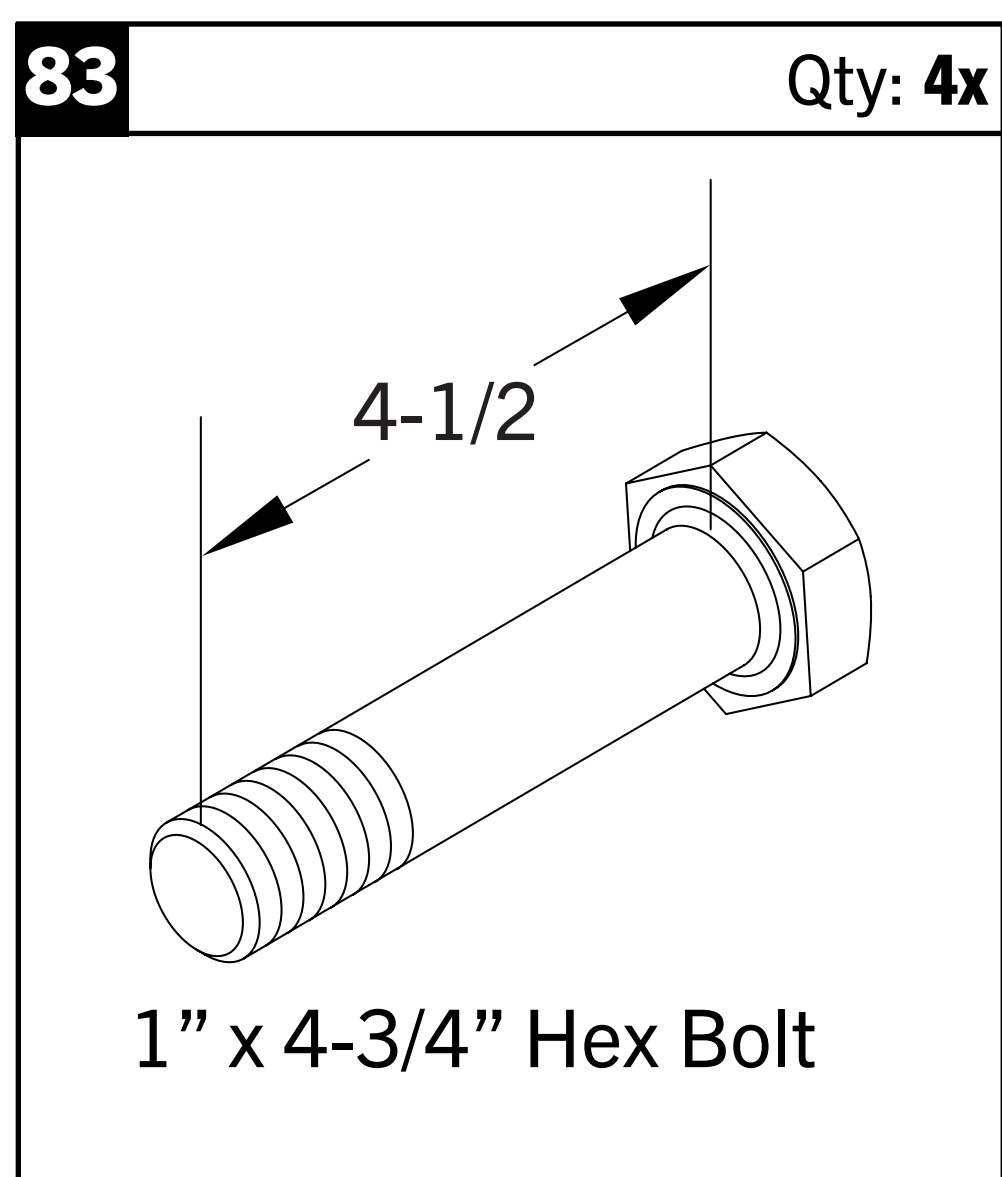
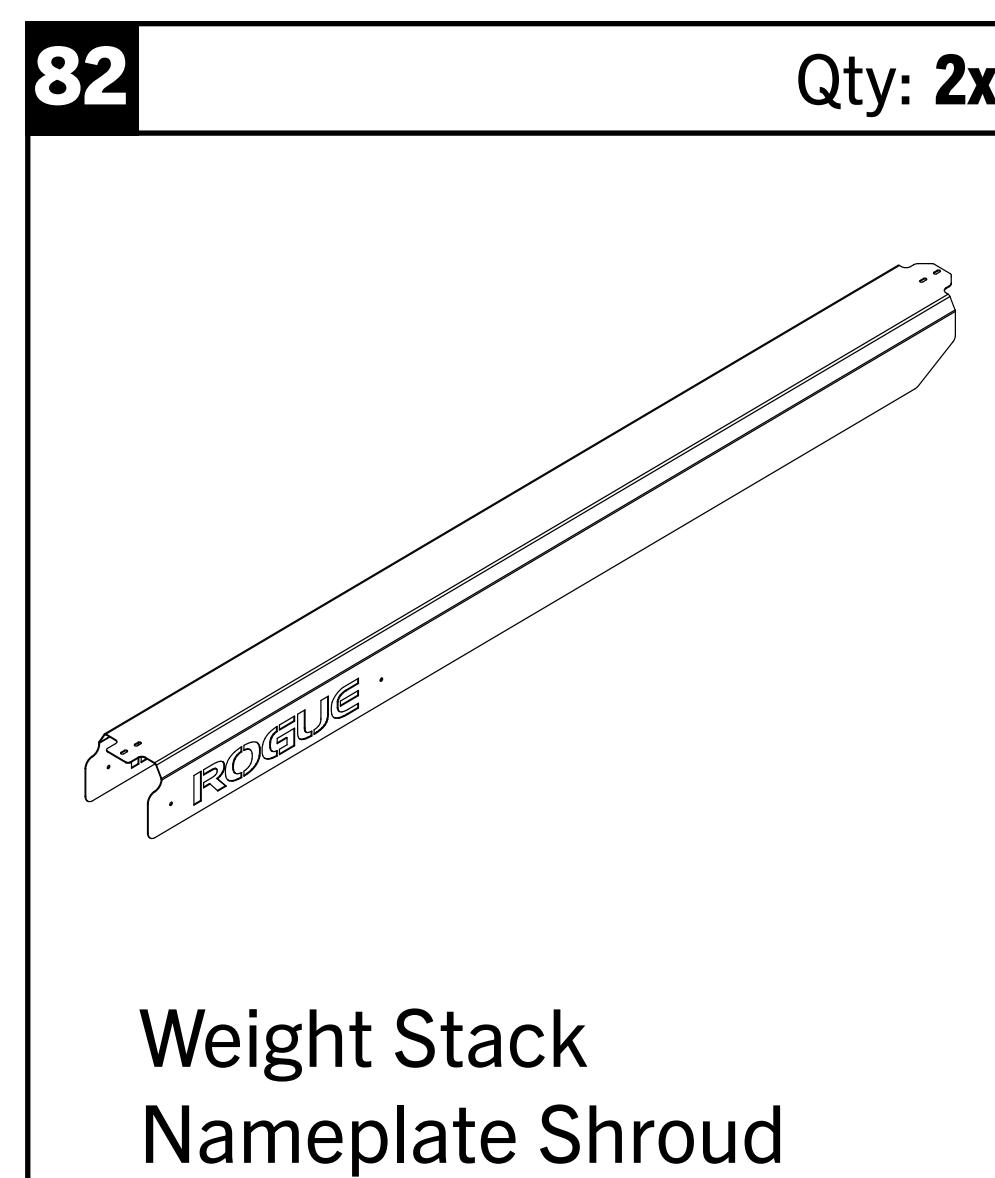
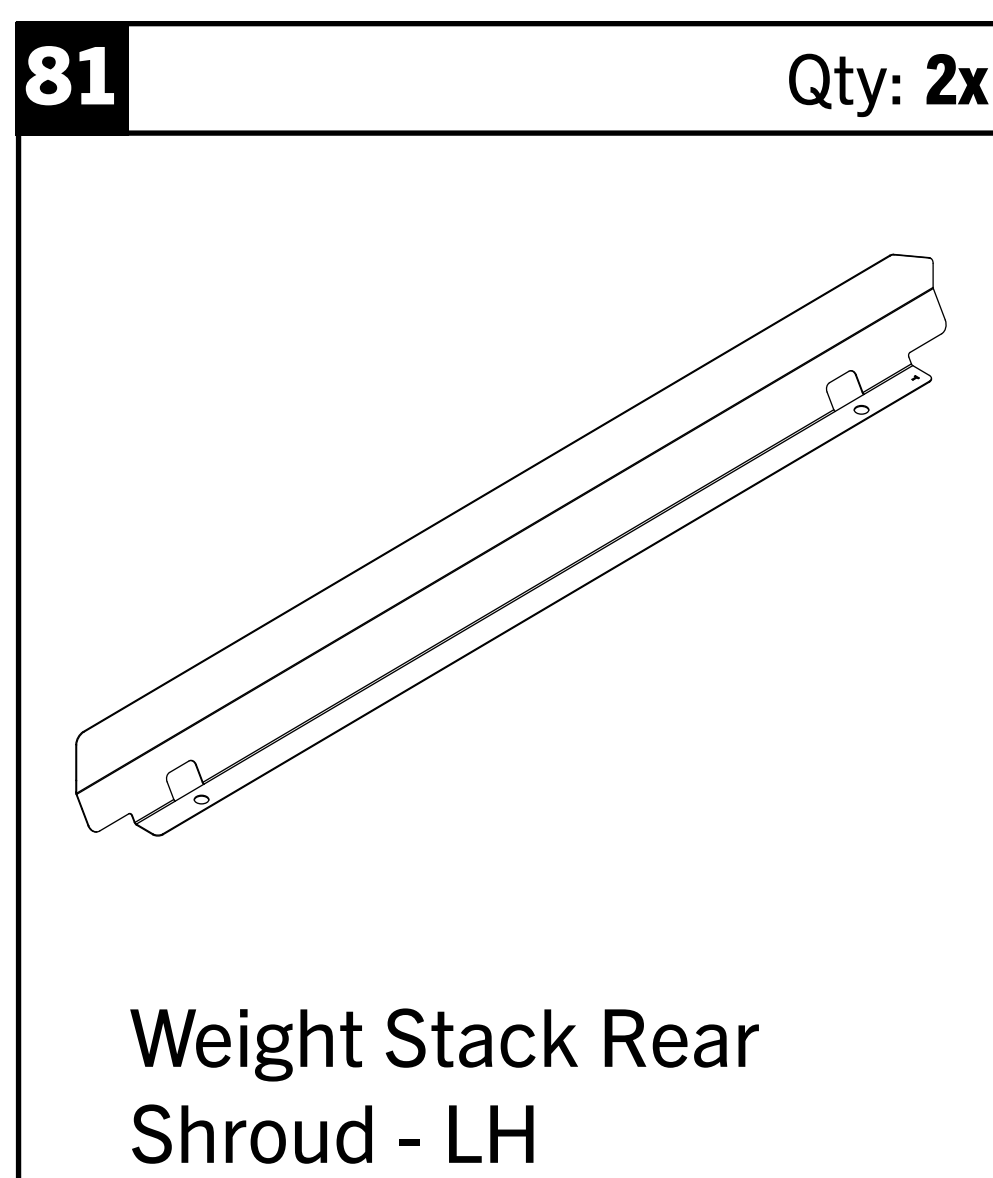
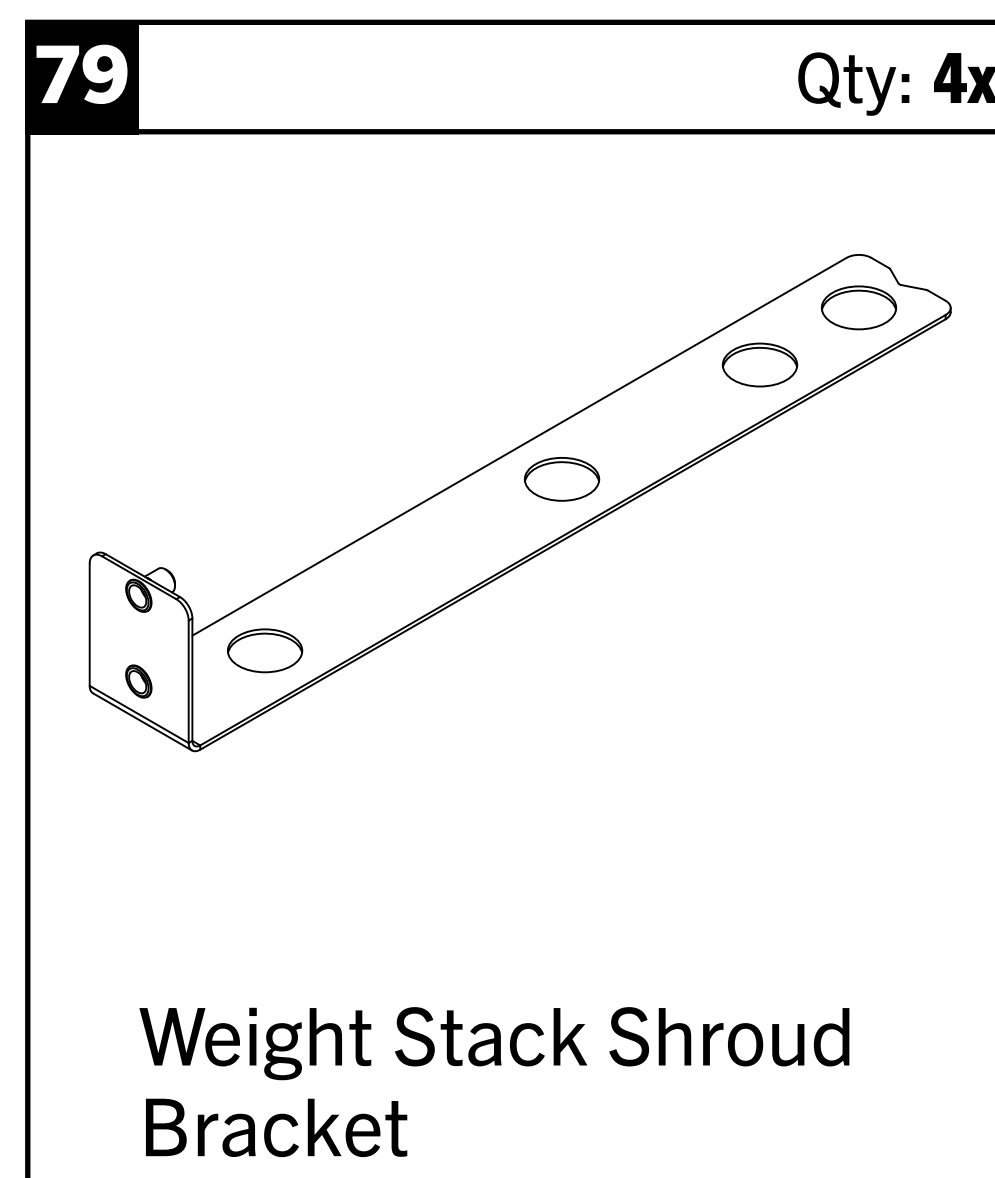
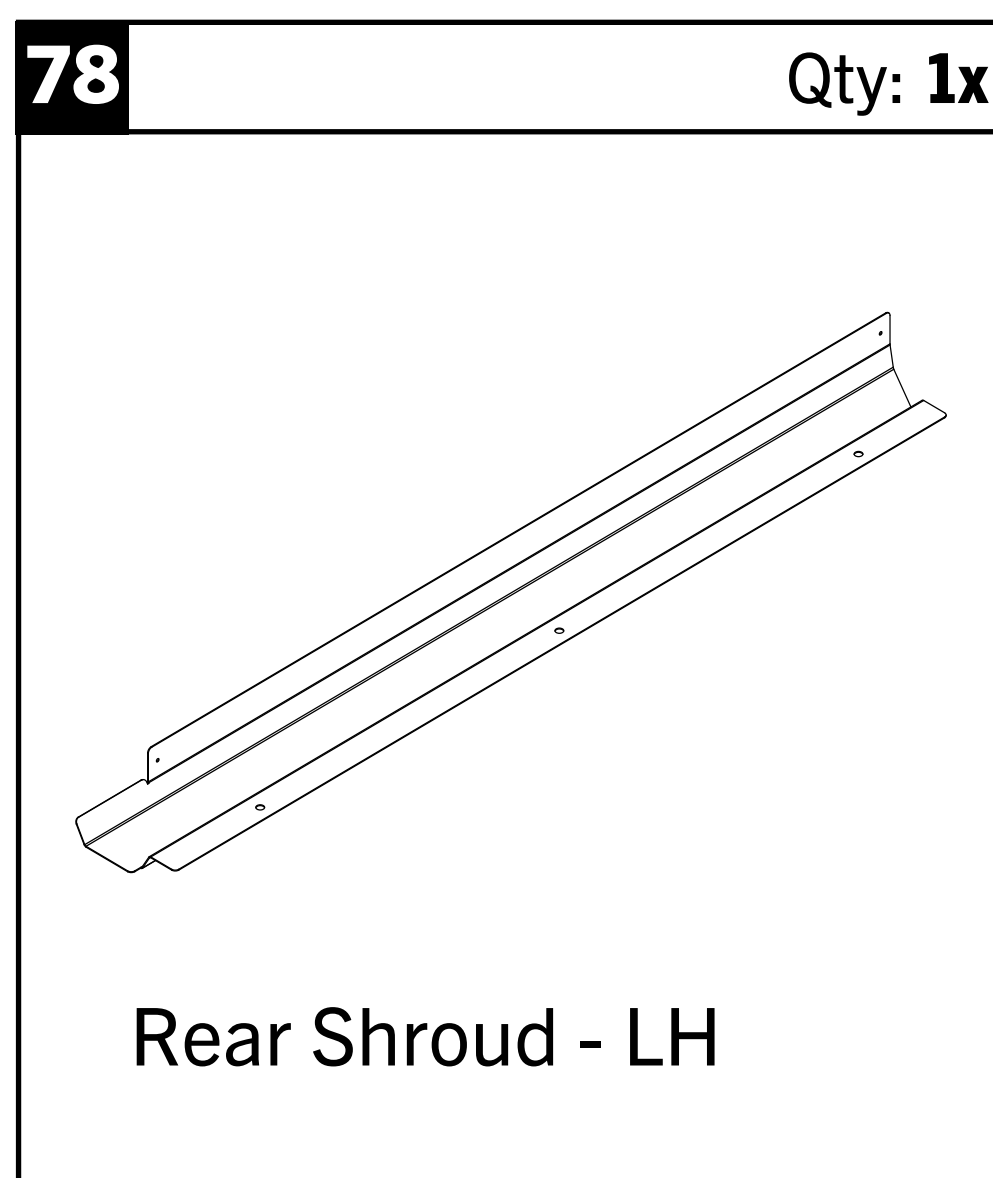
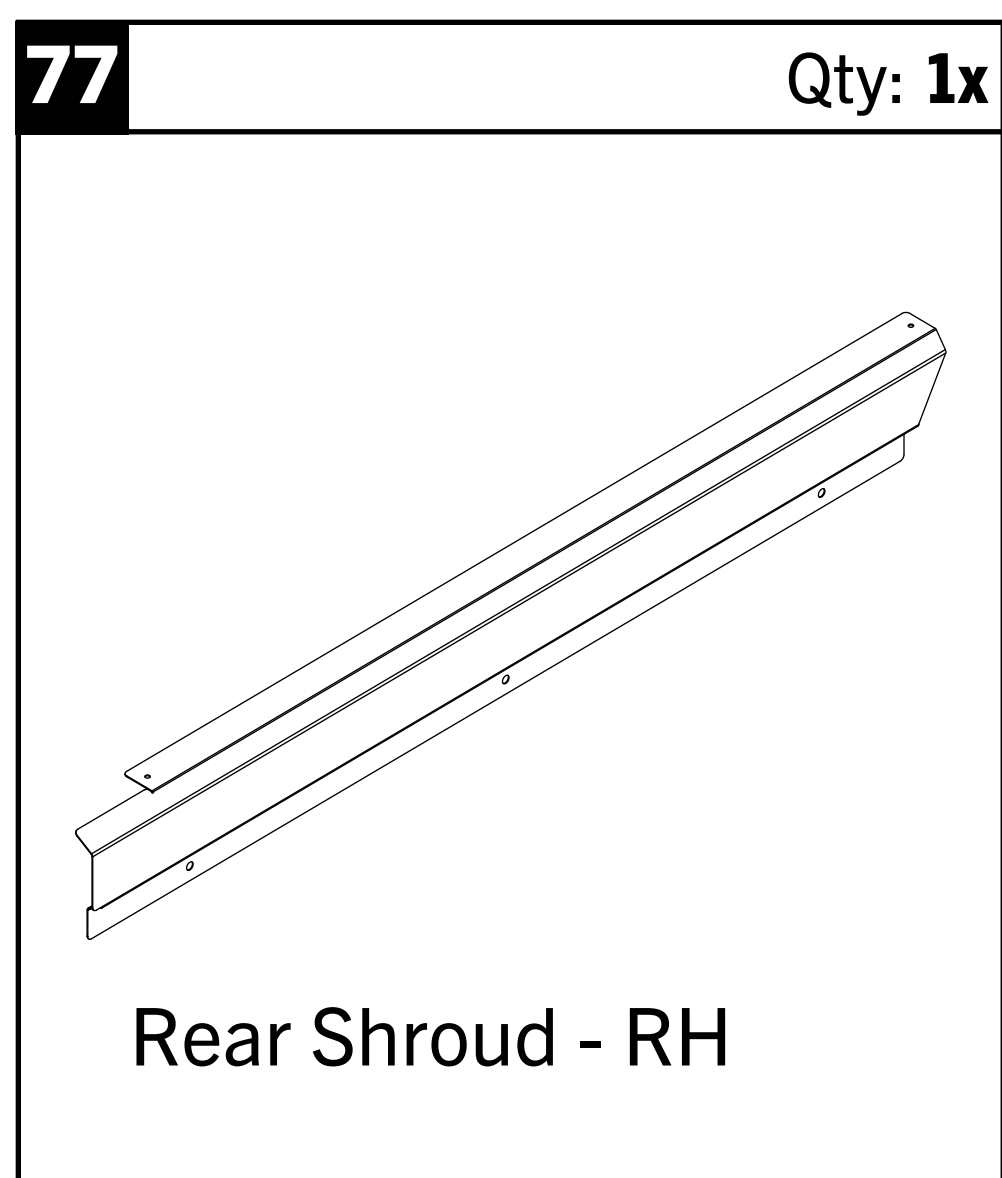

# INCLUDED PARTS: SHROUD KIT

Note: Images not shown at scale.

**89**

Qty: **3x**

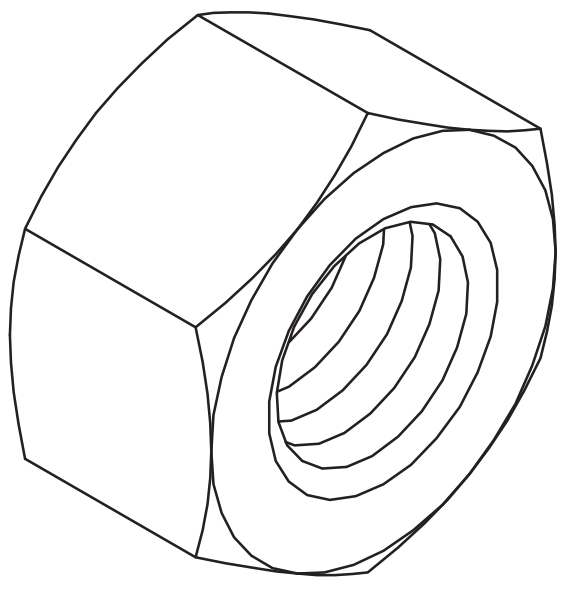

5/8" Hex Nut

**90**

Qty: **10x**

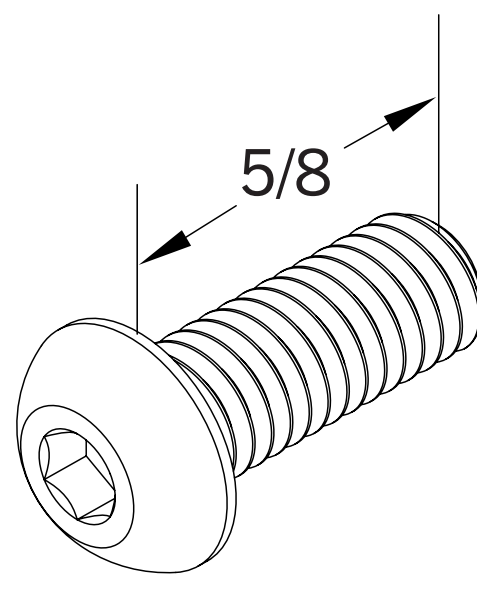

1/4" x 5/8" Button  
Head Screw

# 1" HARDWARE LENGTH GUIDE

**Note:**

- 1" x 5" and 1" x 4-3/4" Bolts shown to scale below to help differentiate variations in length.

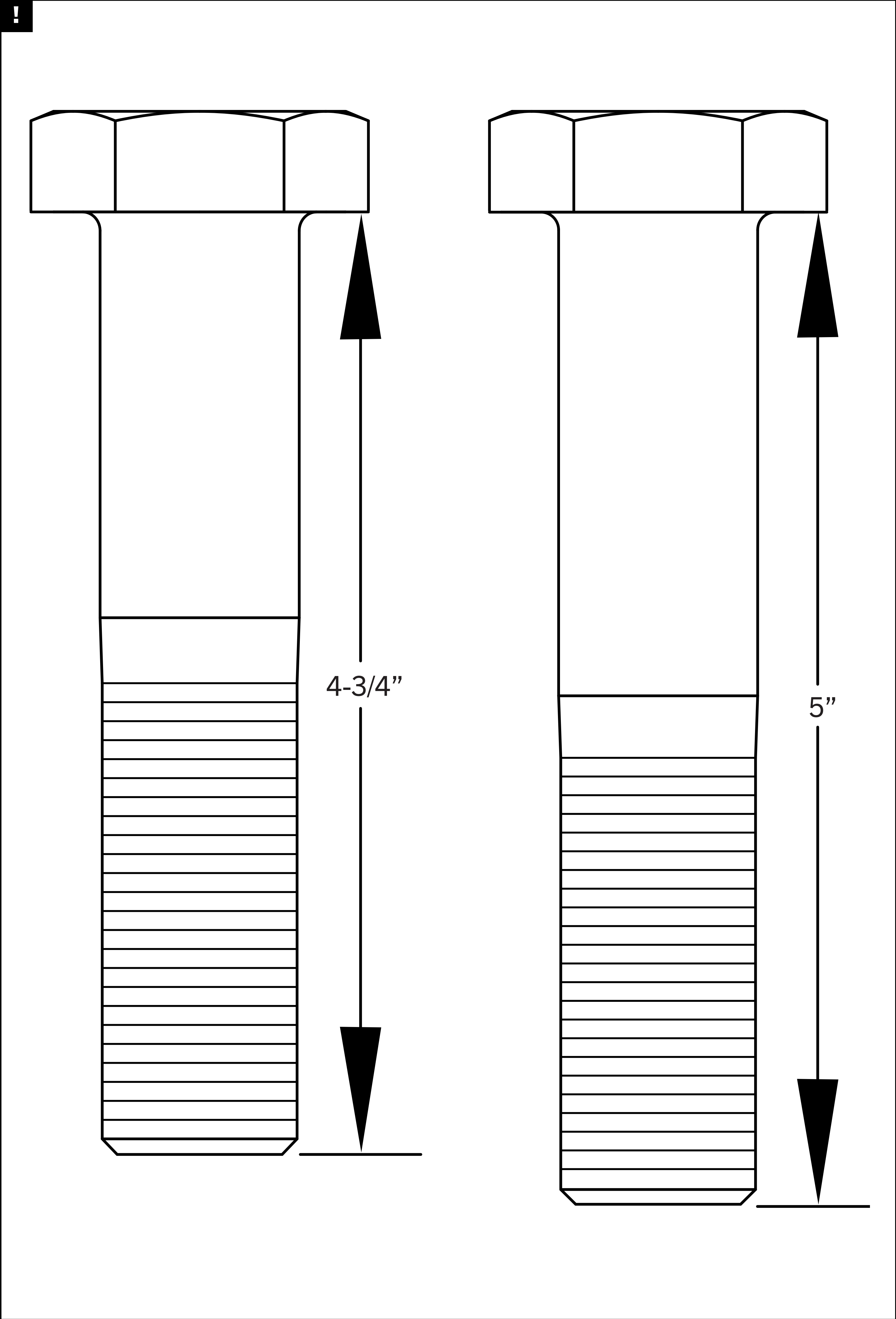

# STEP 1

## Tools Required:

- 3/8" Allen Key
- Multi Tool
- Secure the Pulley Swivel to the Trolley using the preinstalled hardware included with the Pulley Swivel.

- Tighten until there is light friction in the joint, while still allowing the Pulley Swivel to hinge freely.
- Ensure Pulley Swivel is oriented as shown in the correct image.

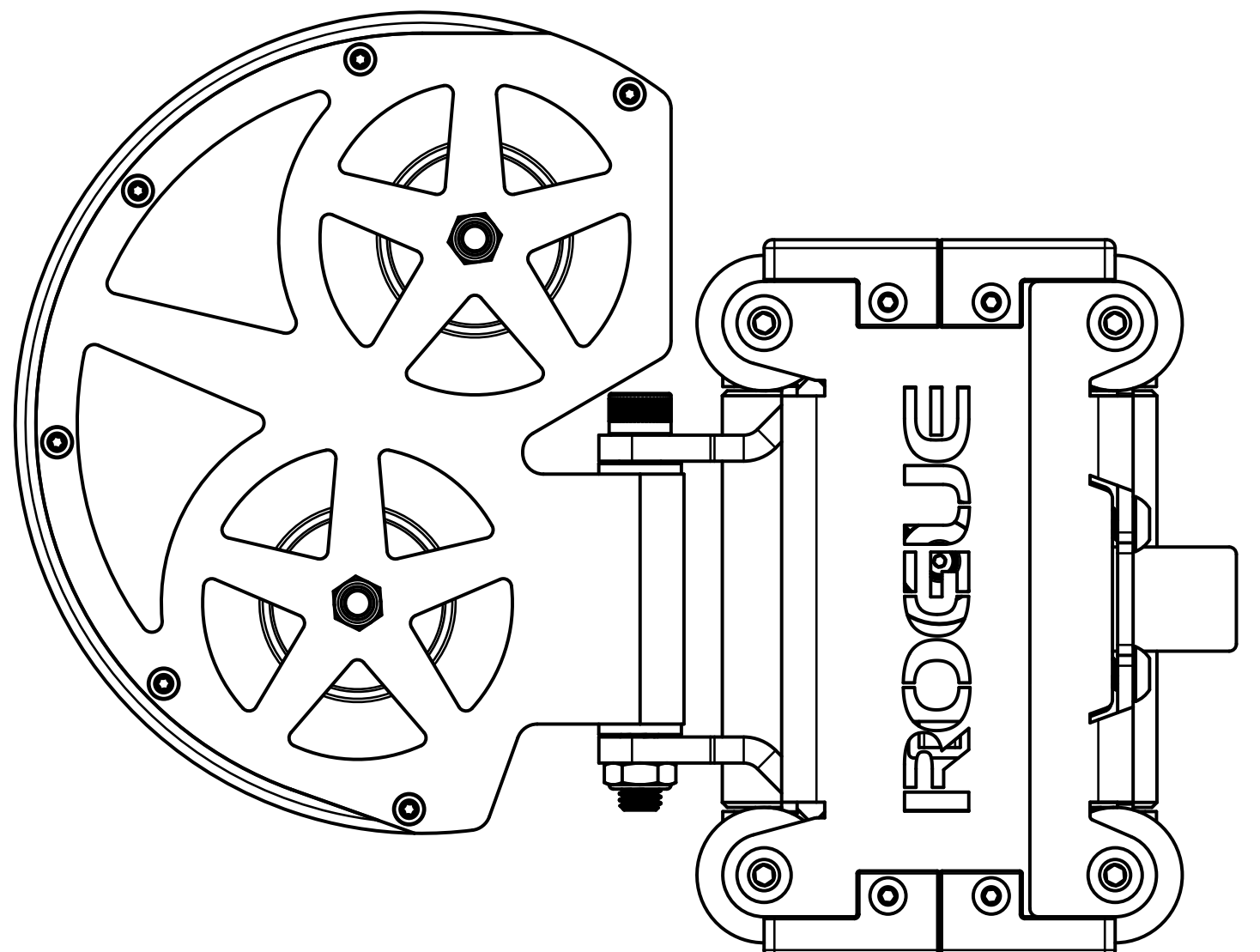
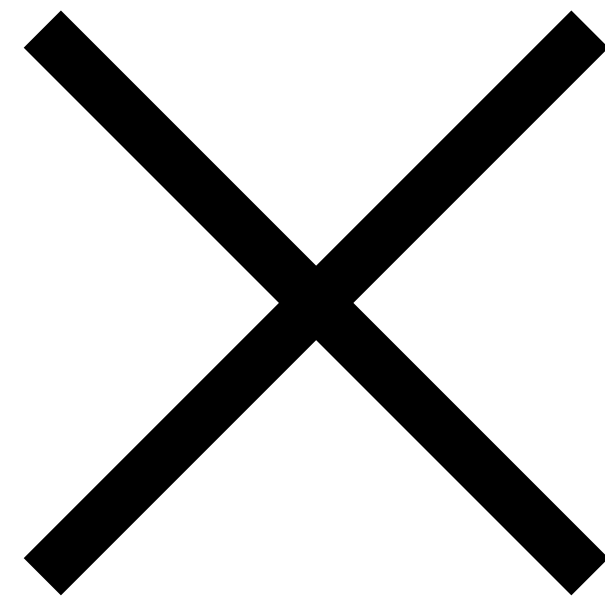
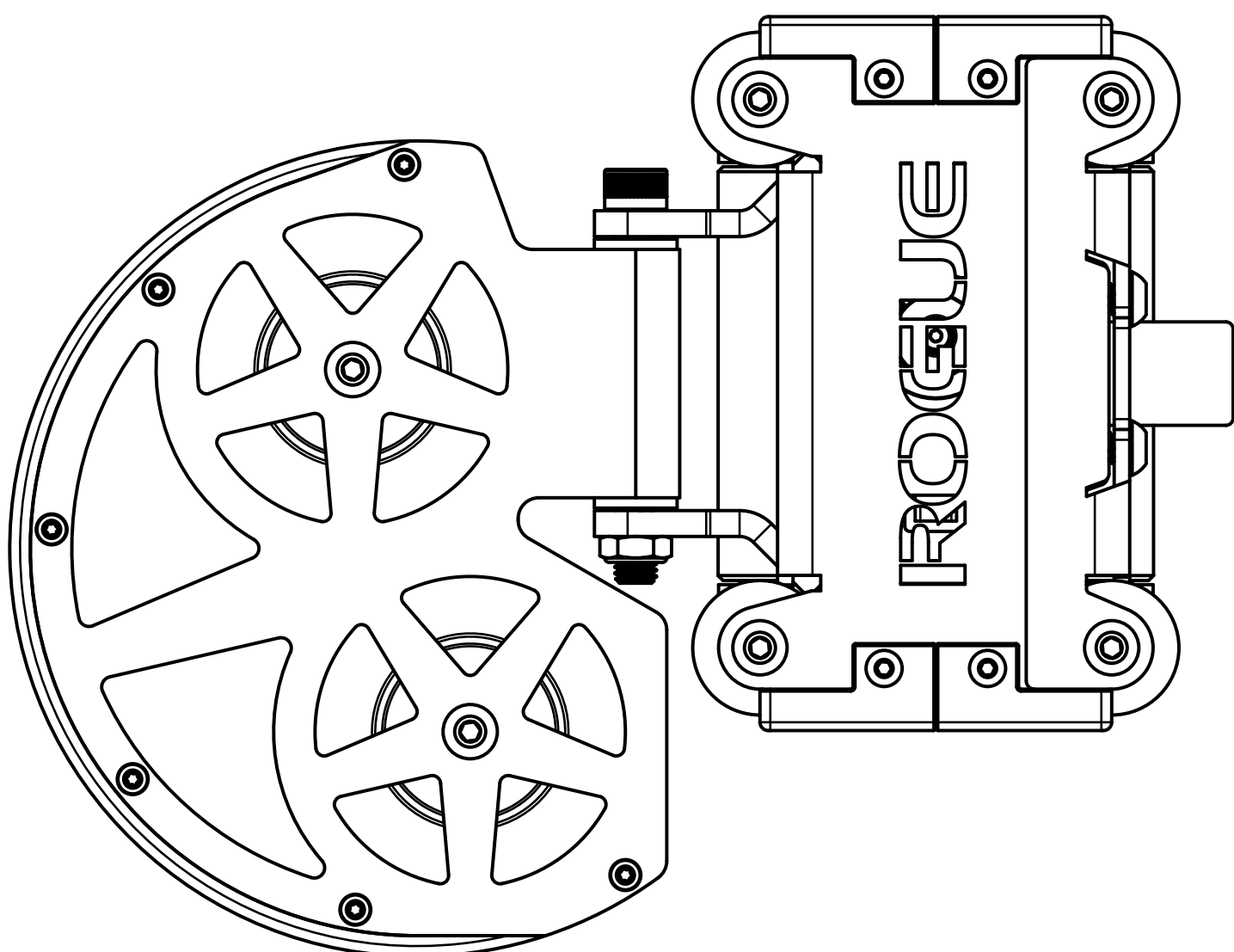
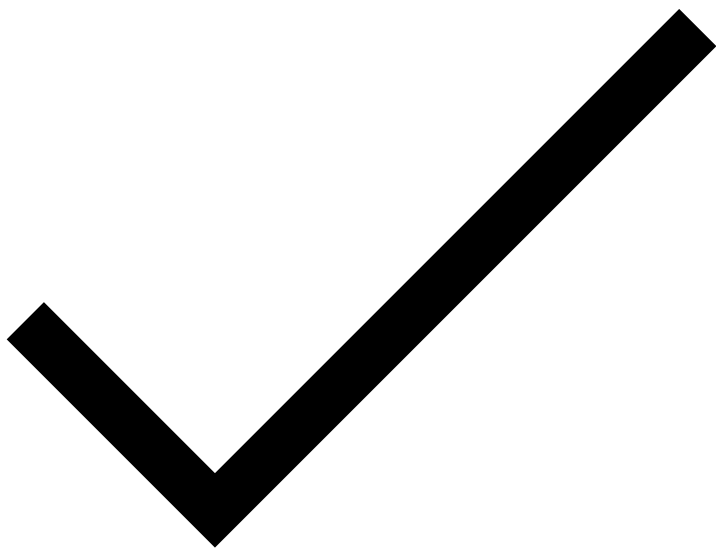
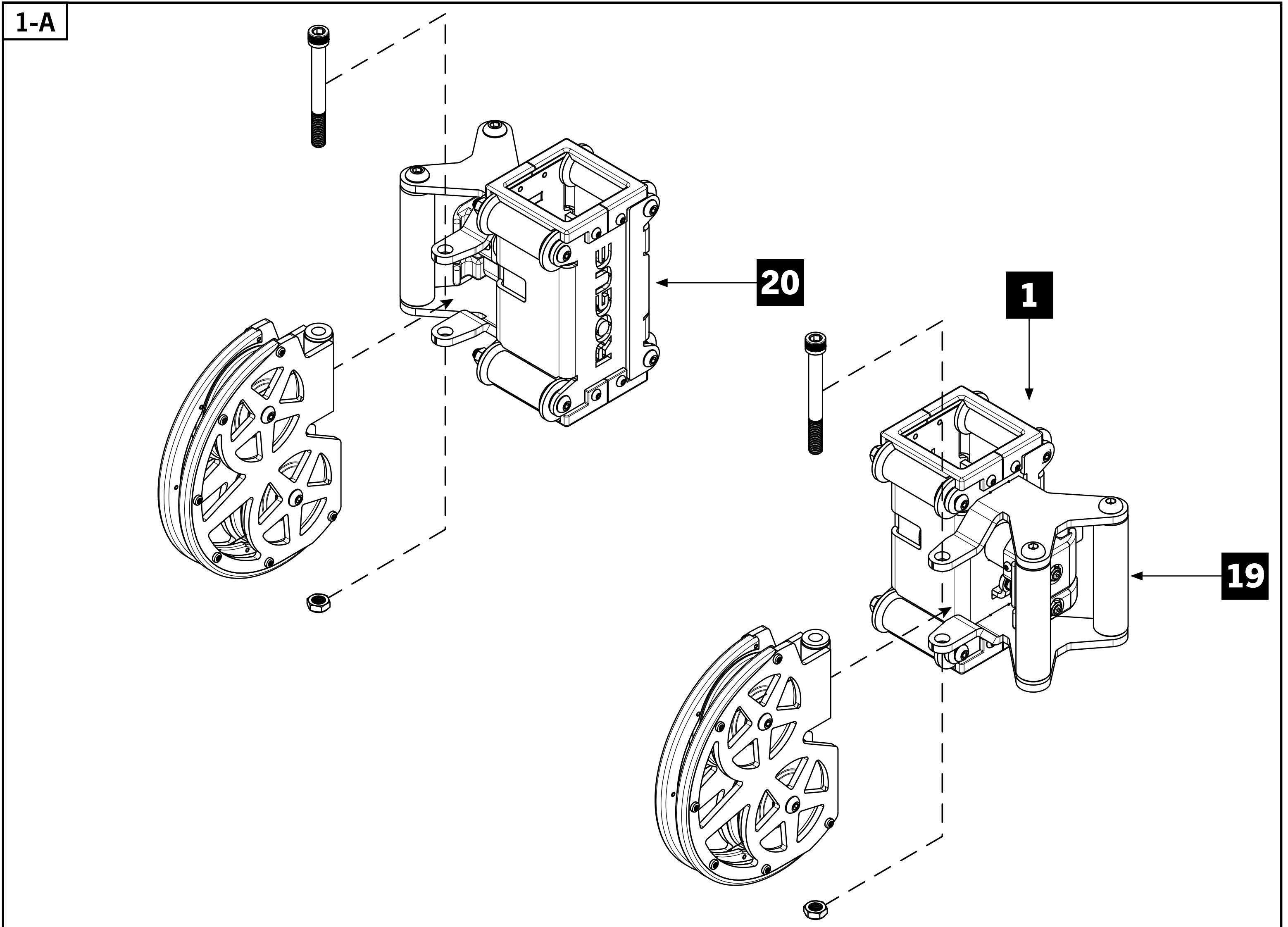

## STEP 2

### IMPORTANT:

• **DO NOT USE TOOLS TO TIGHTEN THROUGHOUT ASSEMBLY UNLESS OTHERWISE SPECIFIED.**

• If modifying existing rack with Add-on Kit, skip Steps 1-4 and proceed to **STEP 5**.

• While pulling the handle triggers, slide Swivel Trolley RH [19] and Swivel Trolley LH [20] onto two Monster Uprights [1].

- Note the orientation of Swivel Trolleys in relation to the feet at bottom of uprights.
- Slide about halfway down Upright and release triggers to lock pop pins in place when the viewing window is showing number 24.

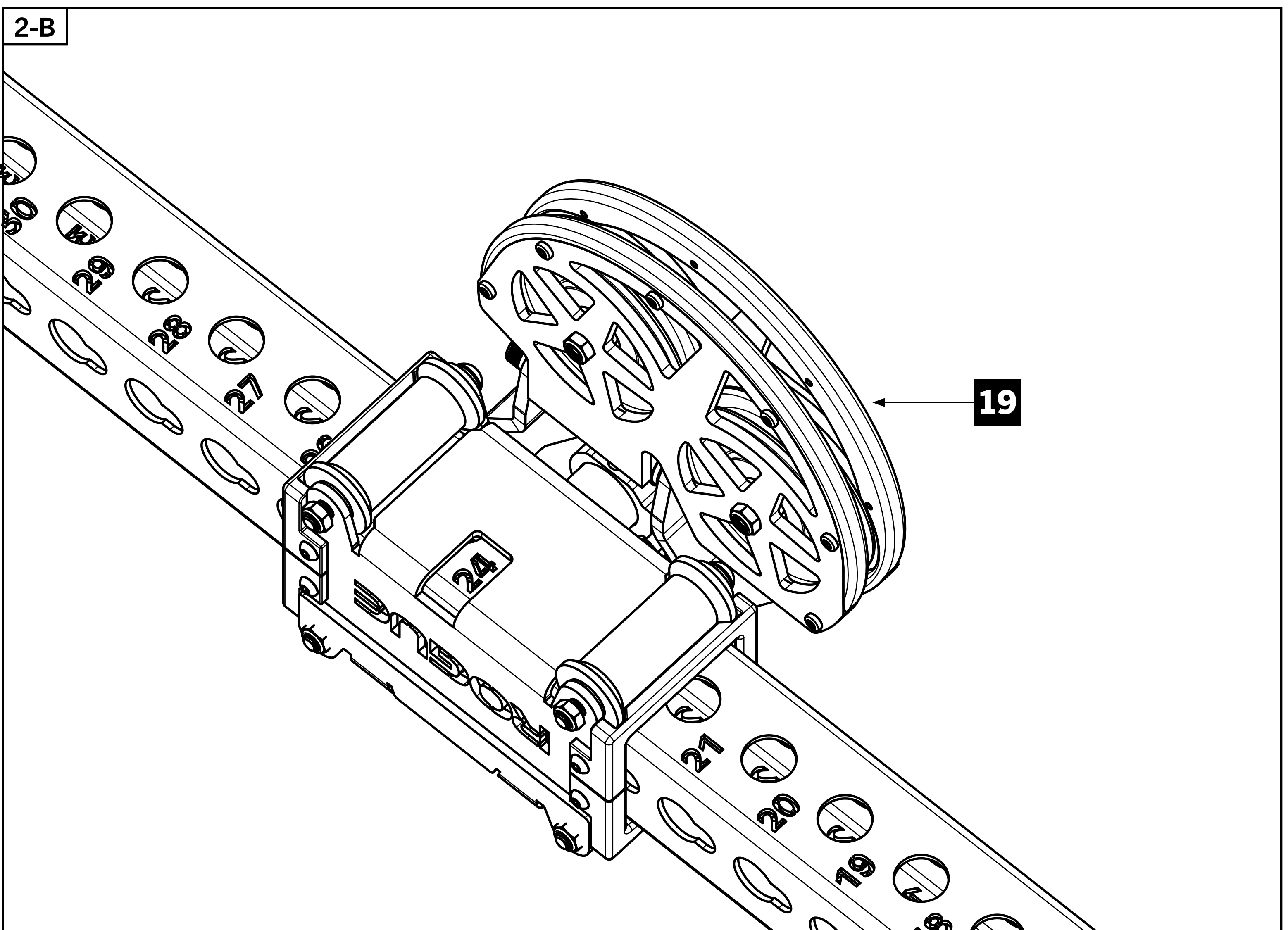
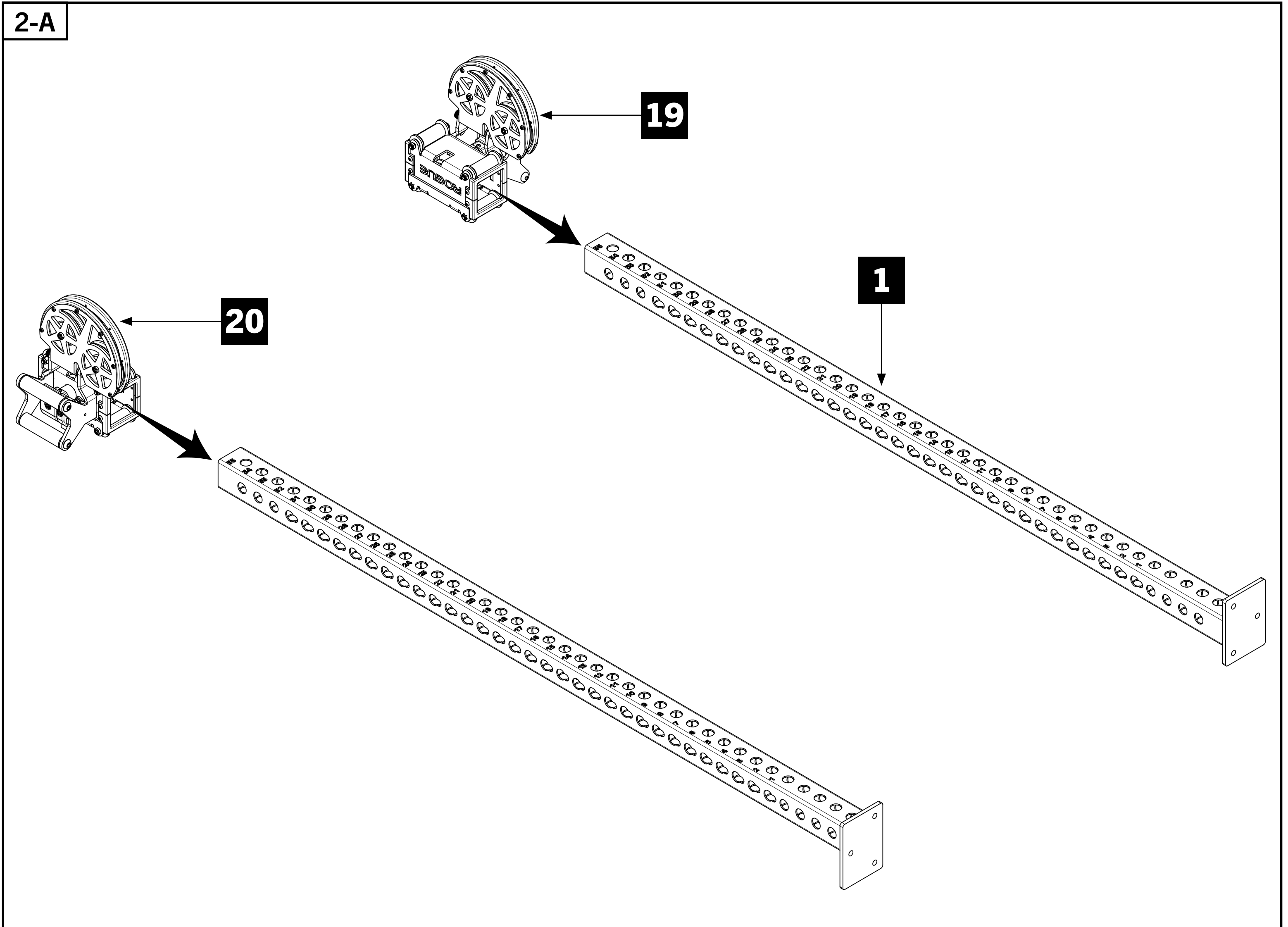

# STEP 3

- Refer to overview image to plan assembly and ensure ample floor space is allotted.
- Lay down all parts on a non-abrasive surface in the orientation shown below.
- Position the footplates of uprights approximately 55" apart.
- Note orientation of Swivel Trolleys and Upright feet in relation to the ground.

- Connect Uprights to Crossmembers using 1"x4-3/4" Hex Bolts [13], 1" x 5" Hex Bolts [12], 1" Flat Washers [14], 1" Lock Washers [15], and 1" Hex Nuts [16].
- Ensure to use 1" x 5" Hex Bolts [12] for central uprights.
- Lower Rear Hardware will be installed in **6-B**.
- **HAND-TIGHTEN ONLY.** Do not use tools throughout assembly unless specified.

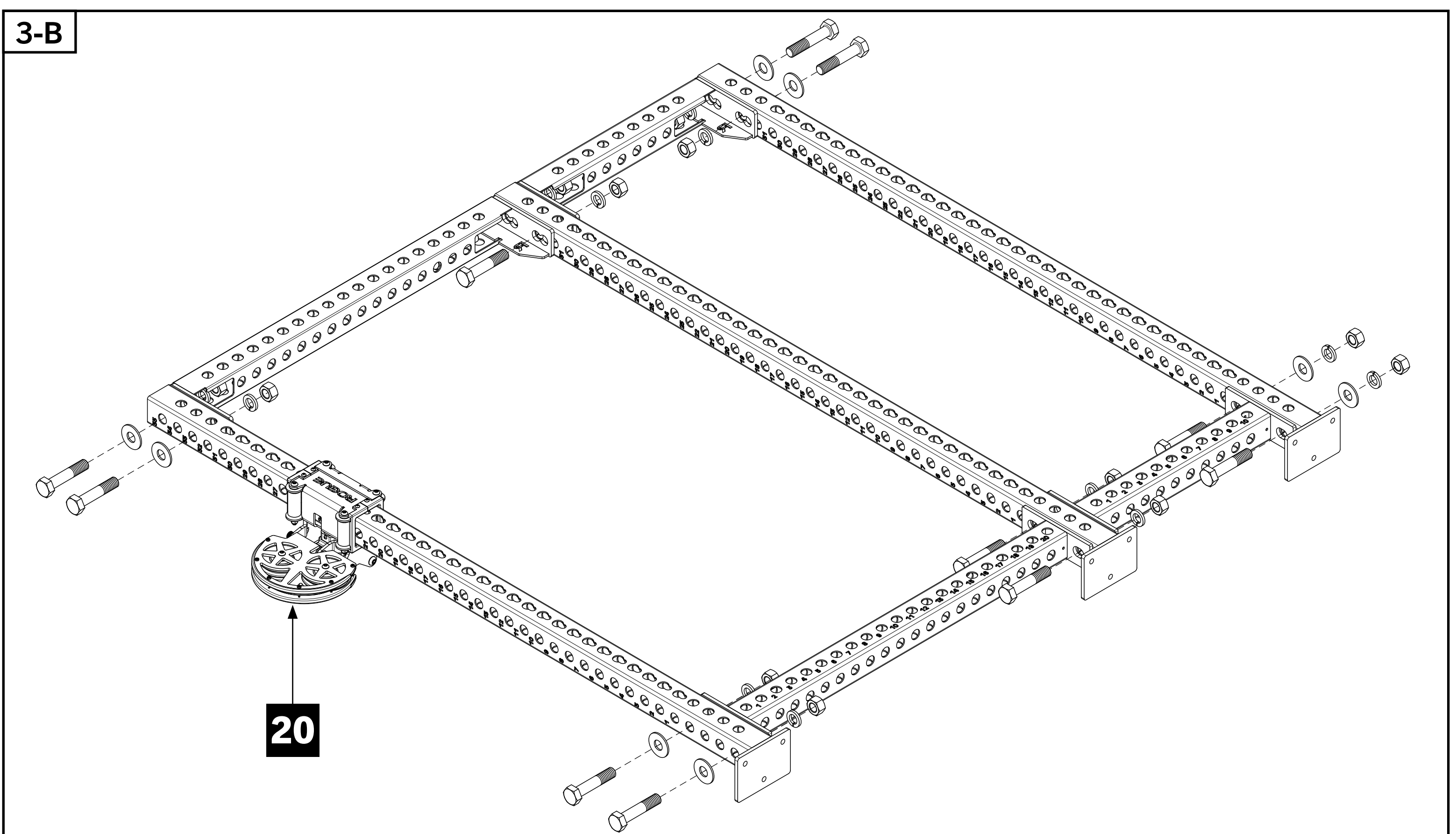
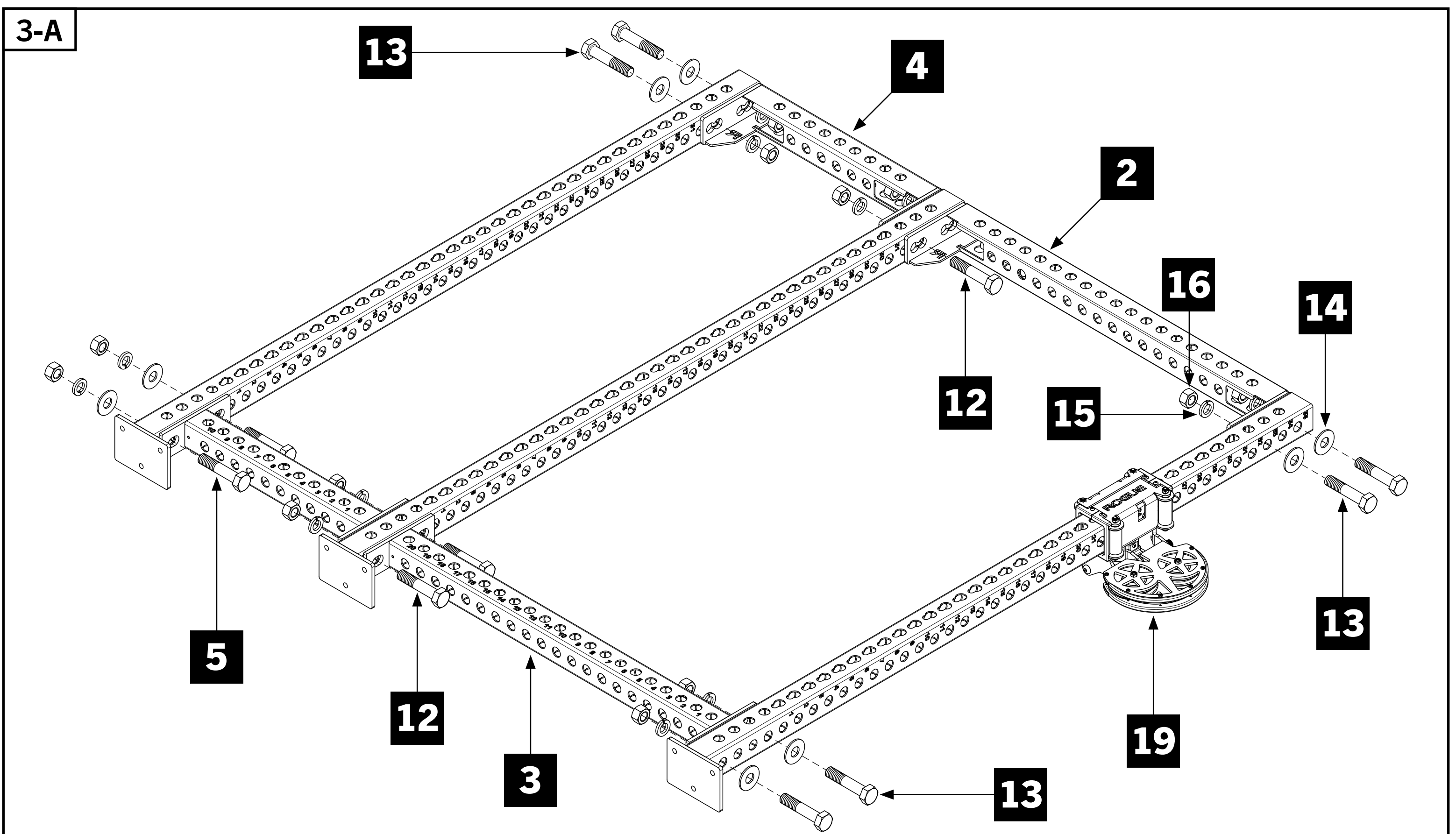
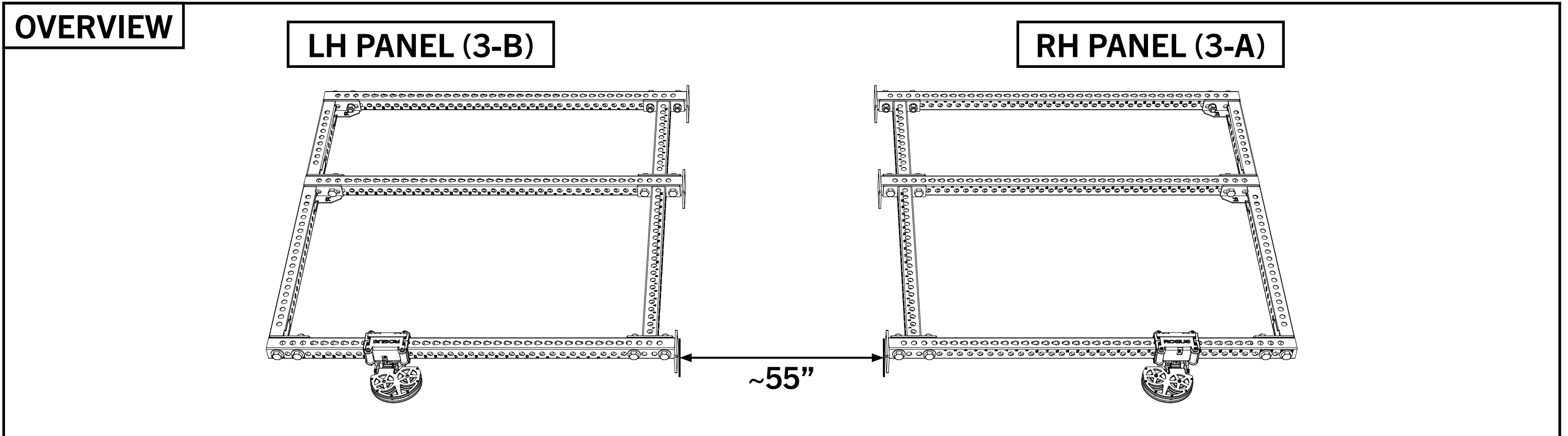

# STEP 4

## IMPORTANT:

- For safety, we recommend the remainder of these instructions be completed by a **minimum of two people**.
- Have two people stand one assembled panel up first.
- One person stabilizes the first panel while the other stands up the second panel.

- One or two people should stabilize both panels, ensuring panels don't fall while another person assembles the spanning Crossmembers in **STEP 5**.

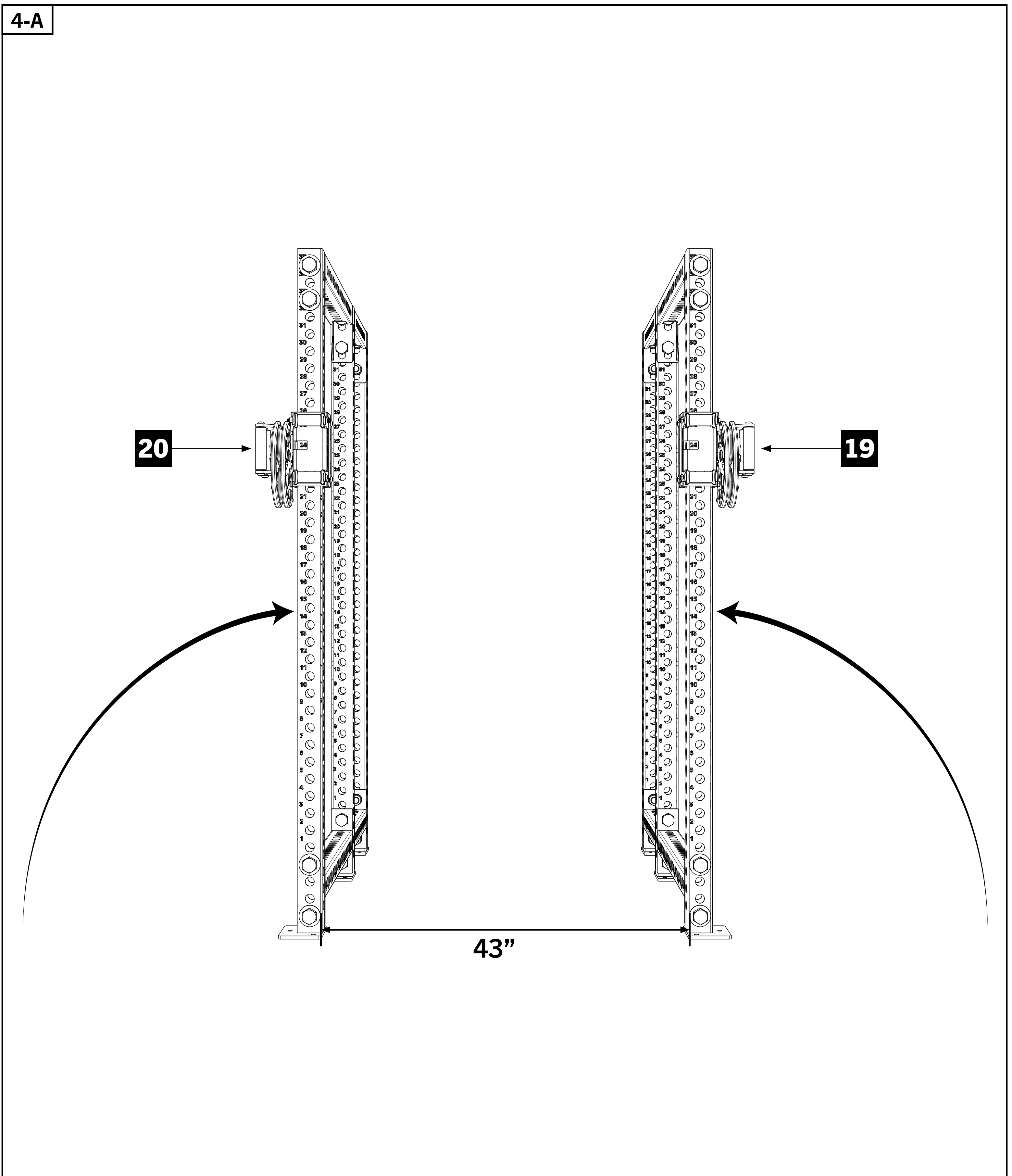
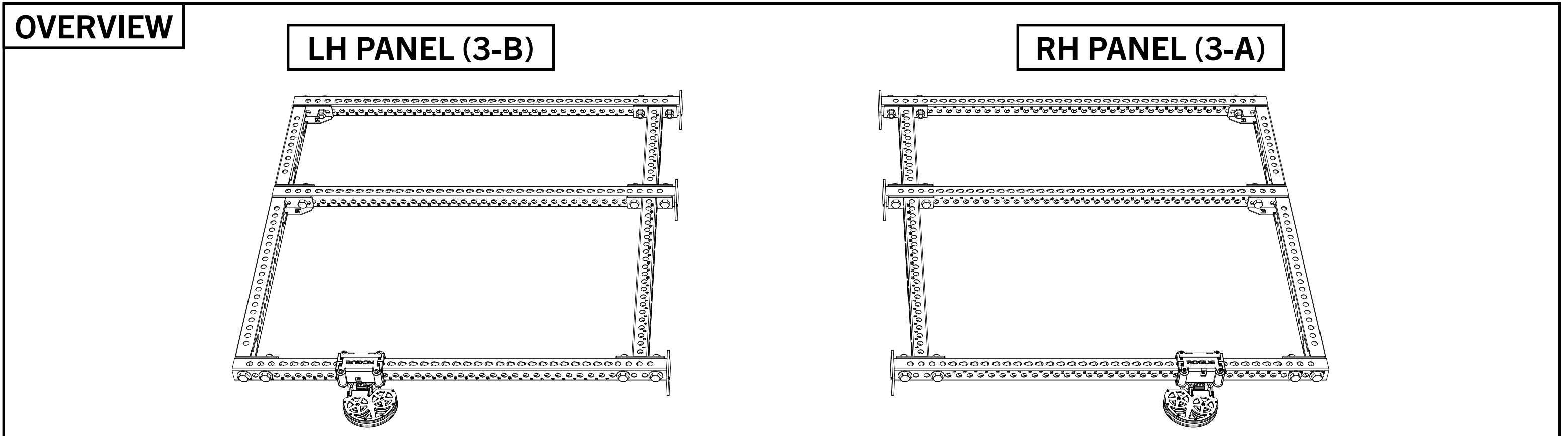

# STEP 5

- Attach Top Crossmember [6] to middle Uprights using 1" x 4-3/4" Hex Bolt [13], 1" Flat Washers [14], 1" Lock Washers [15], and 1" Hex Nuts [16].

- Attach Pull-up Bar [7] to front Uprights using 1" x 4-3/4" Hex Bolts, 1" Flat Washers, 1" Lock Washers, and 1" Hex Nuts.

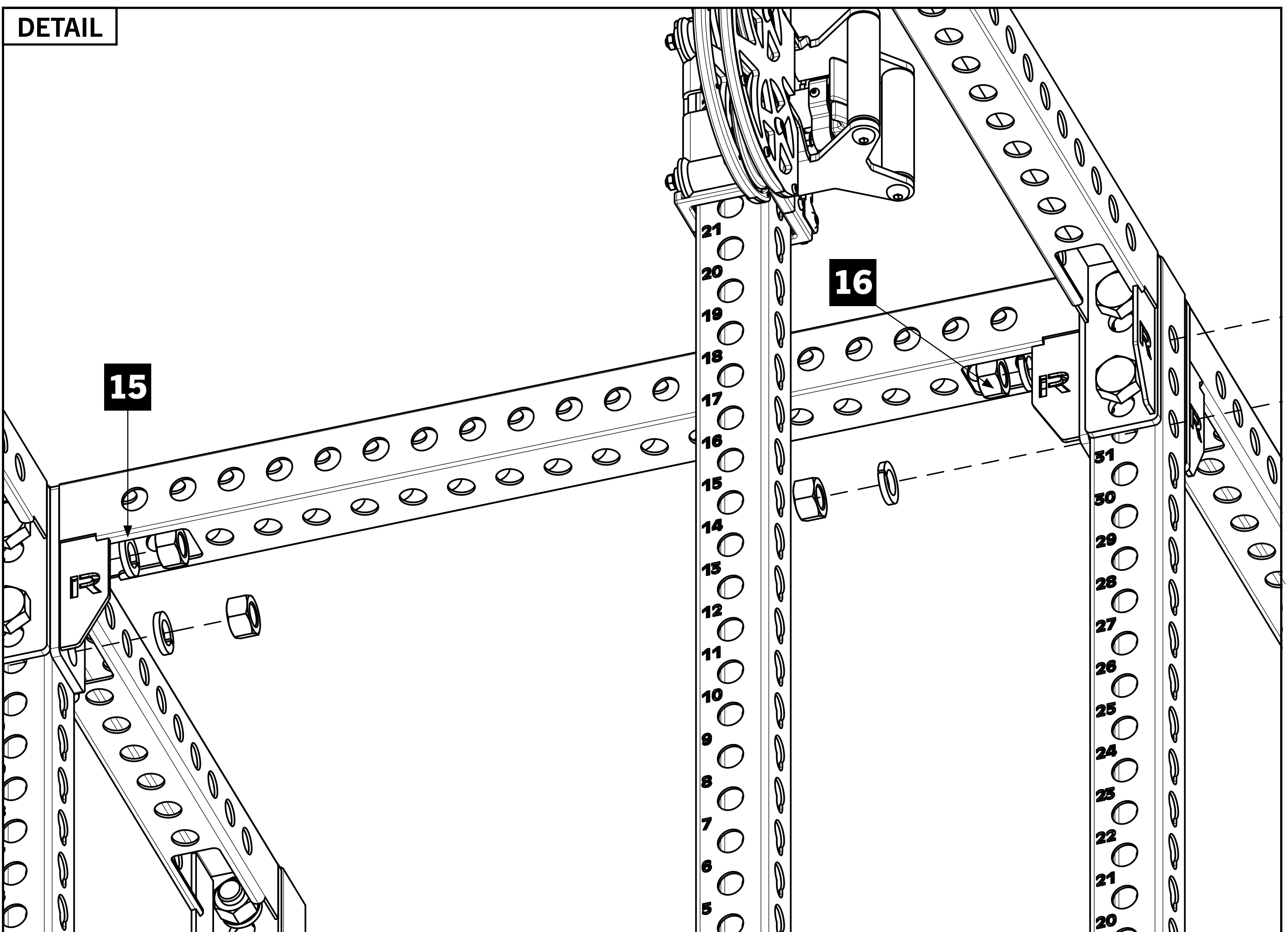
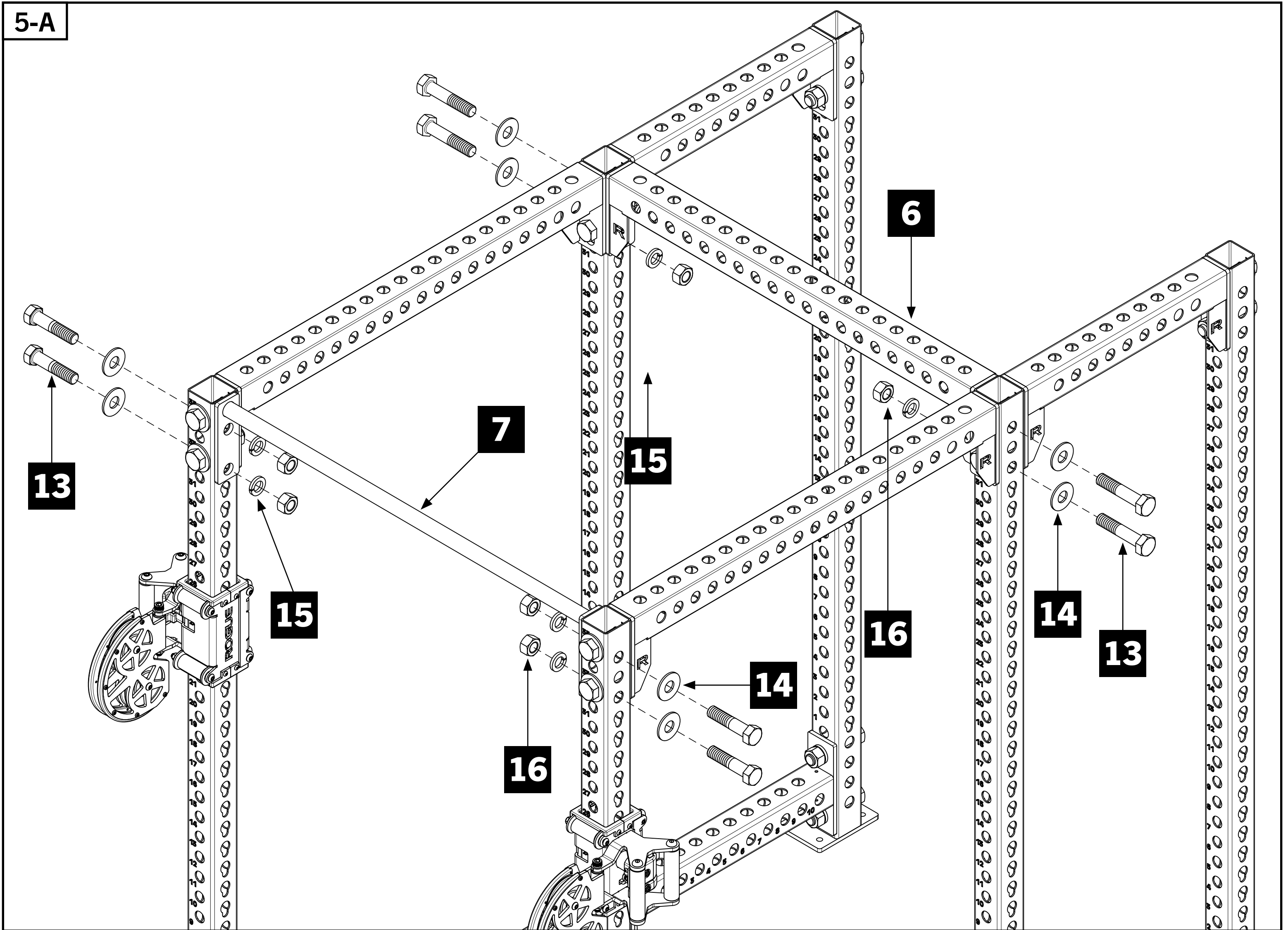

## STEP 6 (BEGIN ADD-ON KIT ASSEMBLY)

- If modifying existing RM rack with add-on kit, begin following assembly instructions.
- If modifying existing RM rack, start by leaving 1" x 4-3/4" Hex Bolts in place, remove all four lower Lock Washers and Hex Nuts from rear Uprights as shown in **6-A**. Attach Low Row Crossmember [**18**] and re-assemble the hardware.
- If you assembled RM rack using these instructions, use hardware pictured in 6-A to attach Low Row Crossmember [**18**] to the rear uprights.

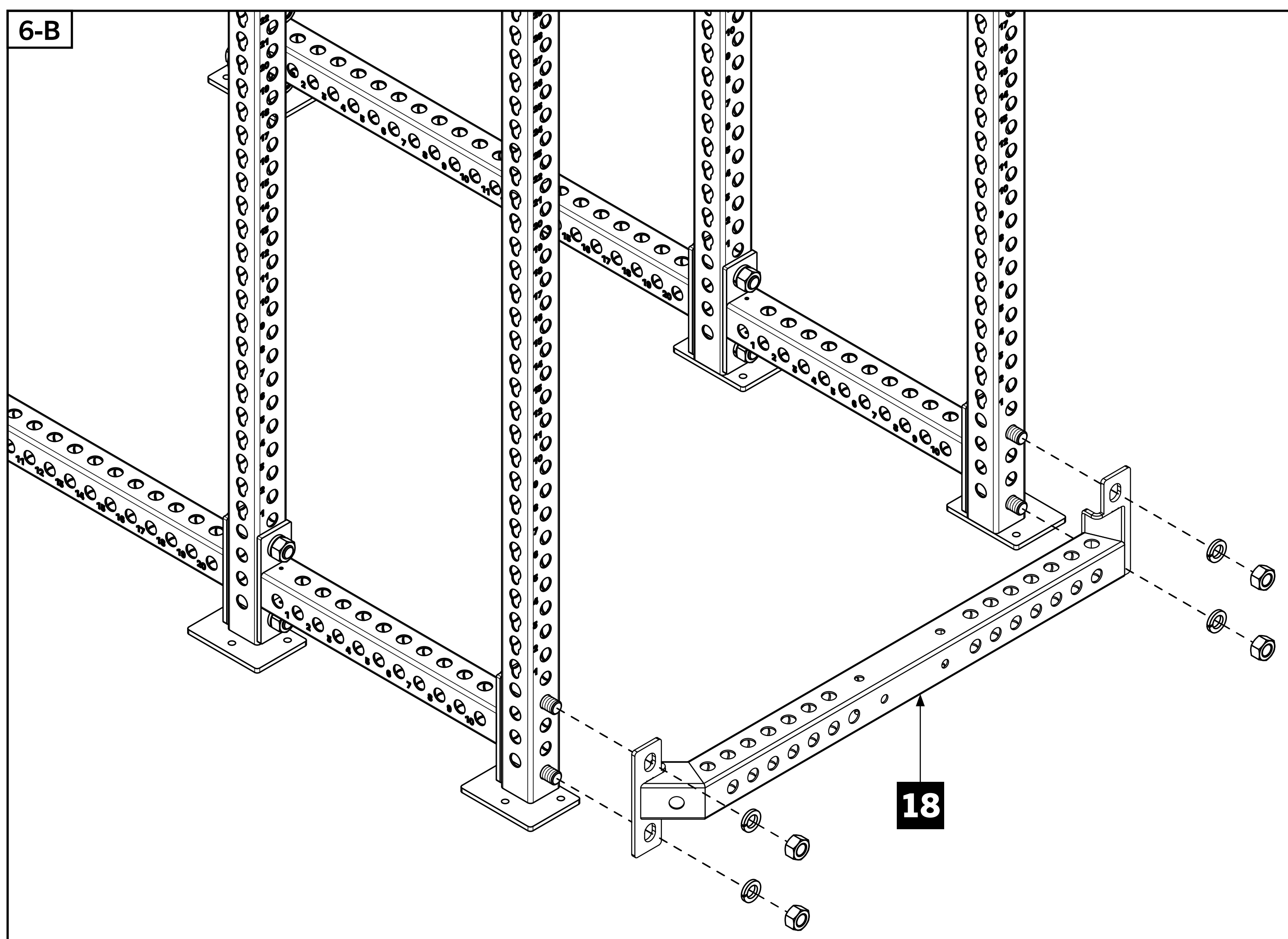
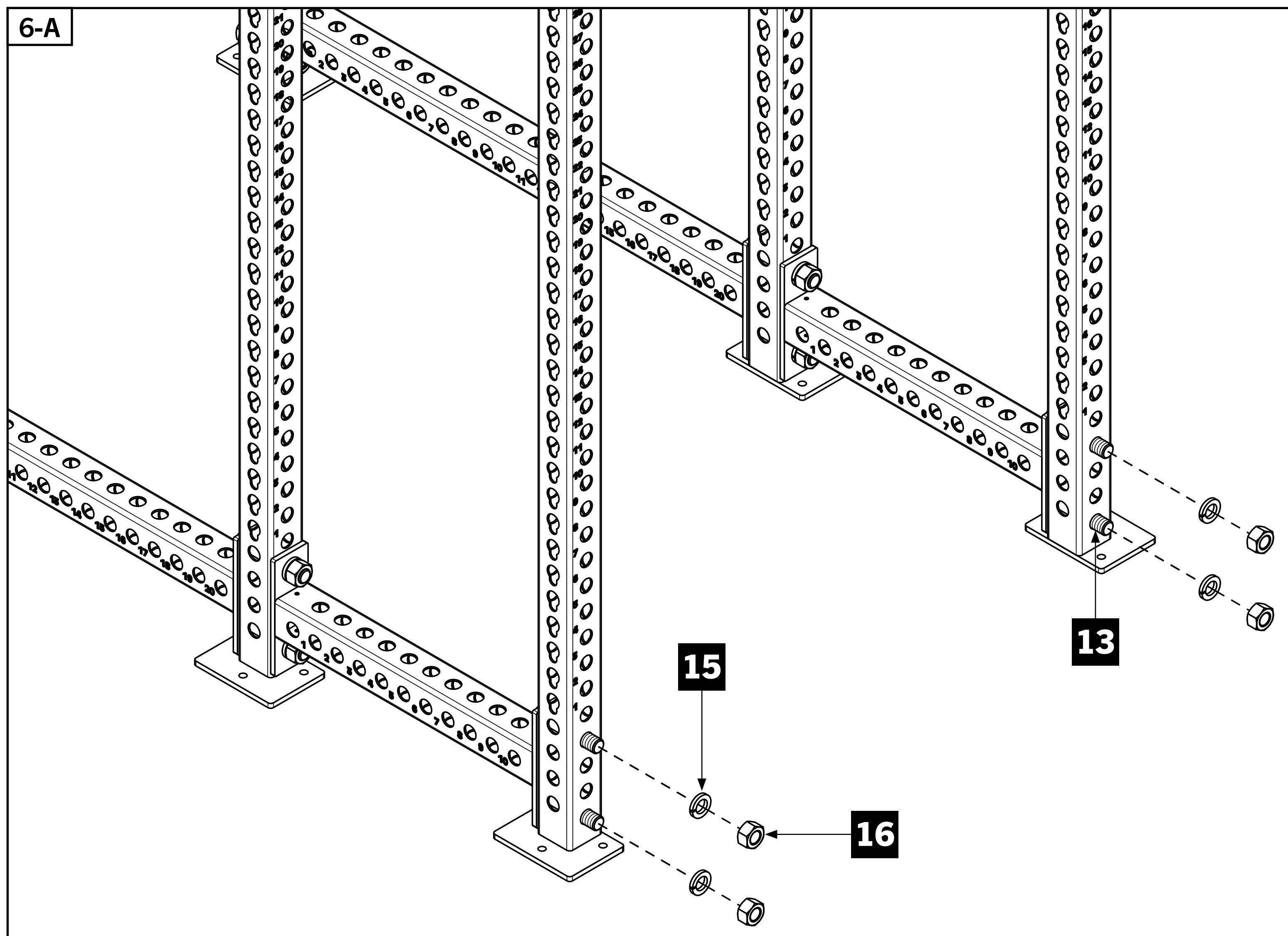

# STEP 7 (ADD-ON KIT ONLY)

## IMPORTANT:

- **LOOSEN BUT DO NOT REMOVE ALL 1" HARDWARE ON ENTIRE RACK.**

## Tools Required:

- 1-1/2" Wrench
- Remove Pull-up Bar and hardware from front of rack and set parts aside.
- Remove additional 1" crossmember hardware shown in **7-B** so that the tops of the front uprights are completely free to move.

## Note:

- The tops of the front uprights will need ample slack to complete **STEP 8**. Continue to loosen hardware on bottom of Front Uprights as needed.

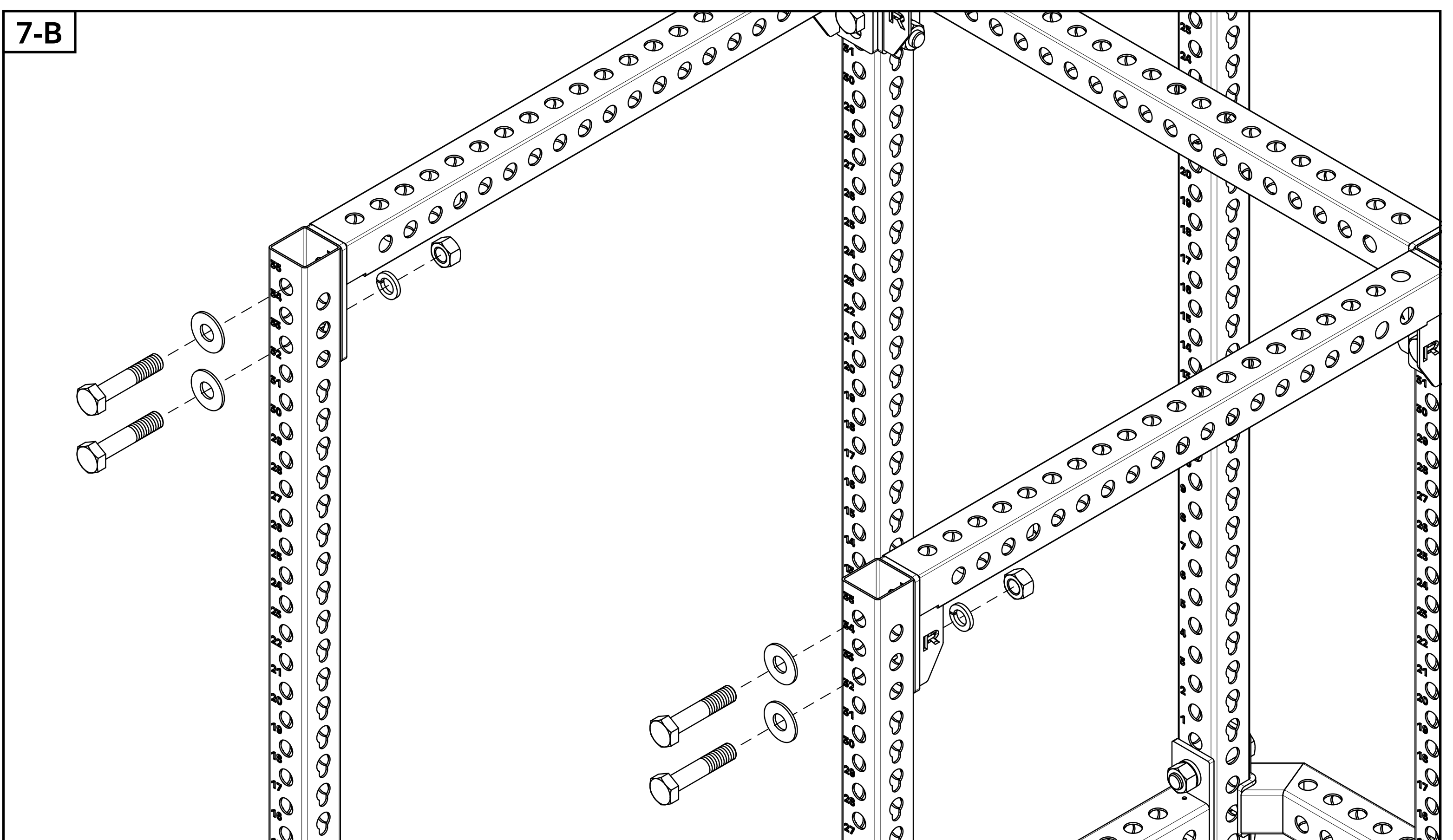
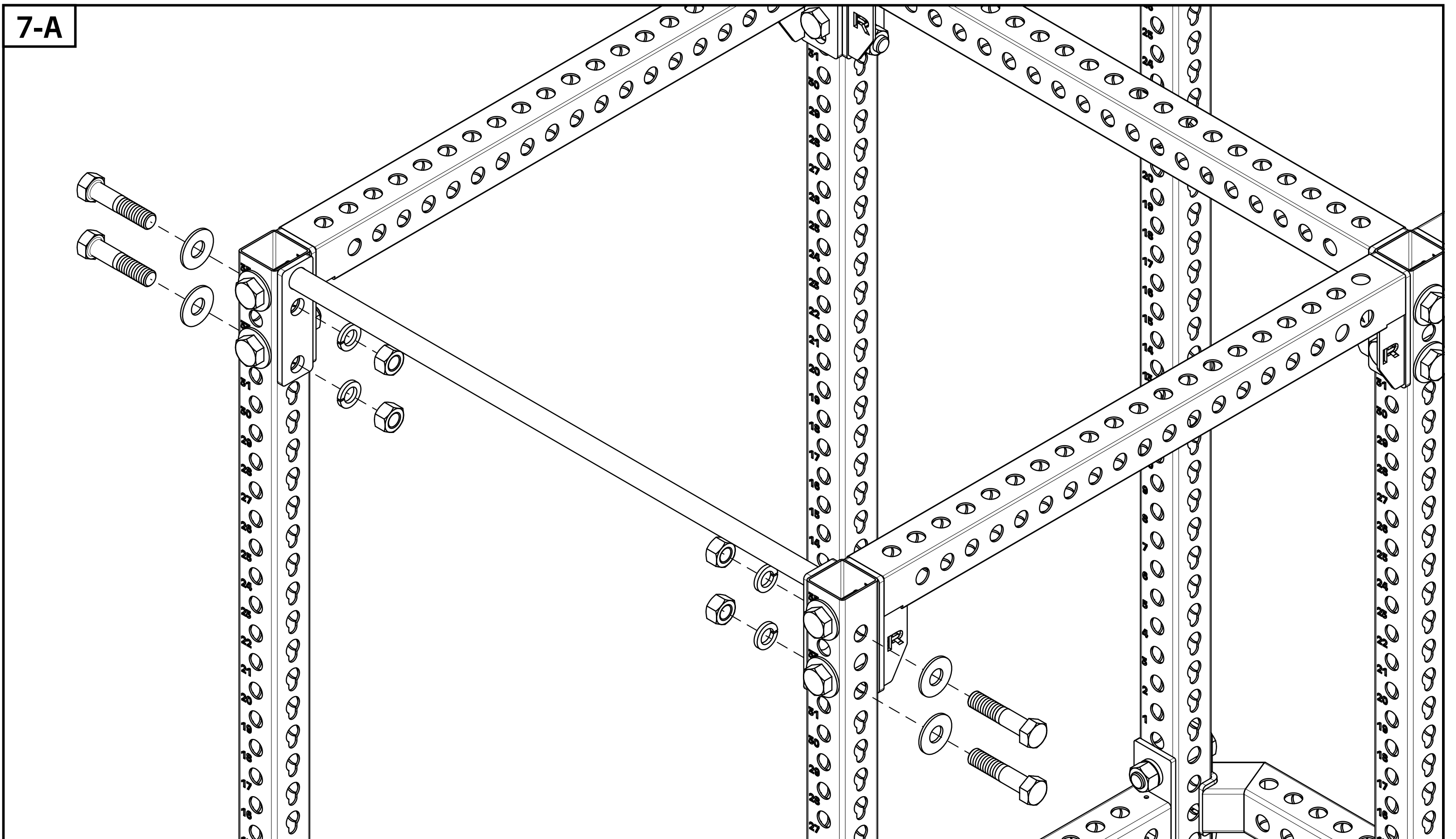
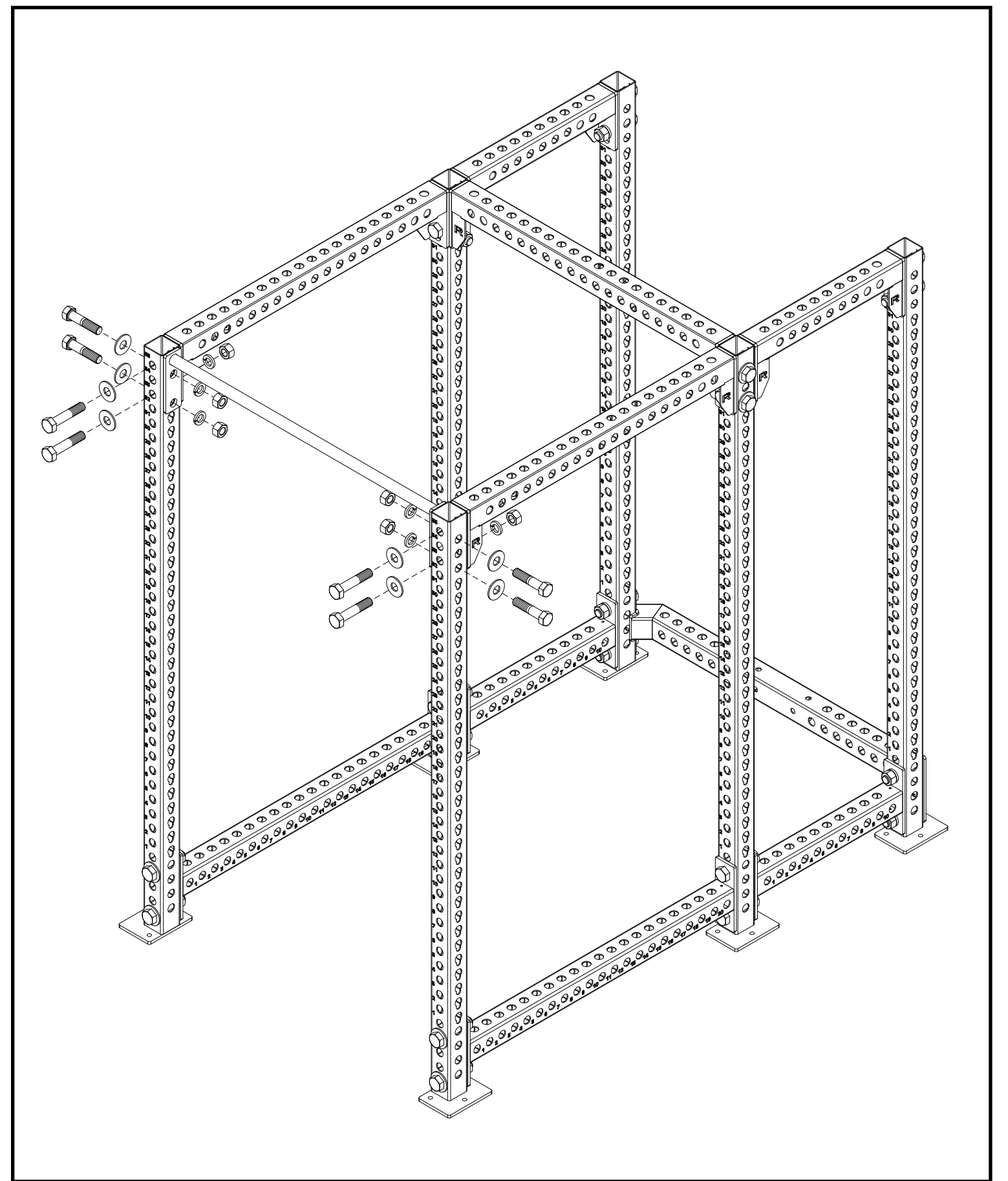

## STEP 8 (ADD-ON KIT ONLY)

- While tilting Upright forward, pull the handle triggers and slide LH Swivel Trolley [20] down the front left Upright.
- Repeat this process to assemble RH Swivel Trolley [19] on front right Upright.
- Slide down the Uprights and release triggers when the viewing window is showing the number 24 (refer to **STEP 2-B**).

- Assemble hardware removed in **STEP 7**.

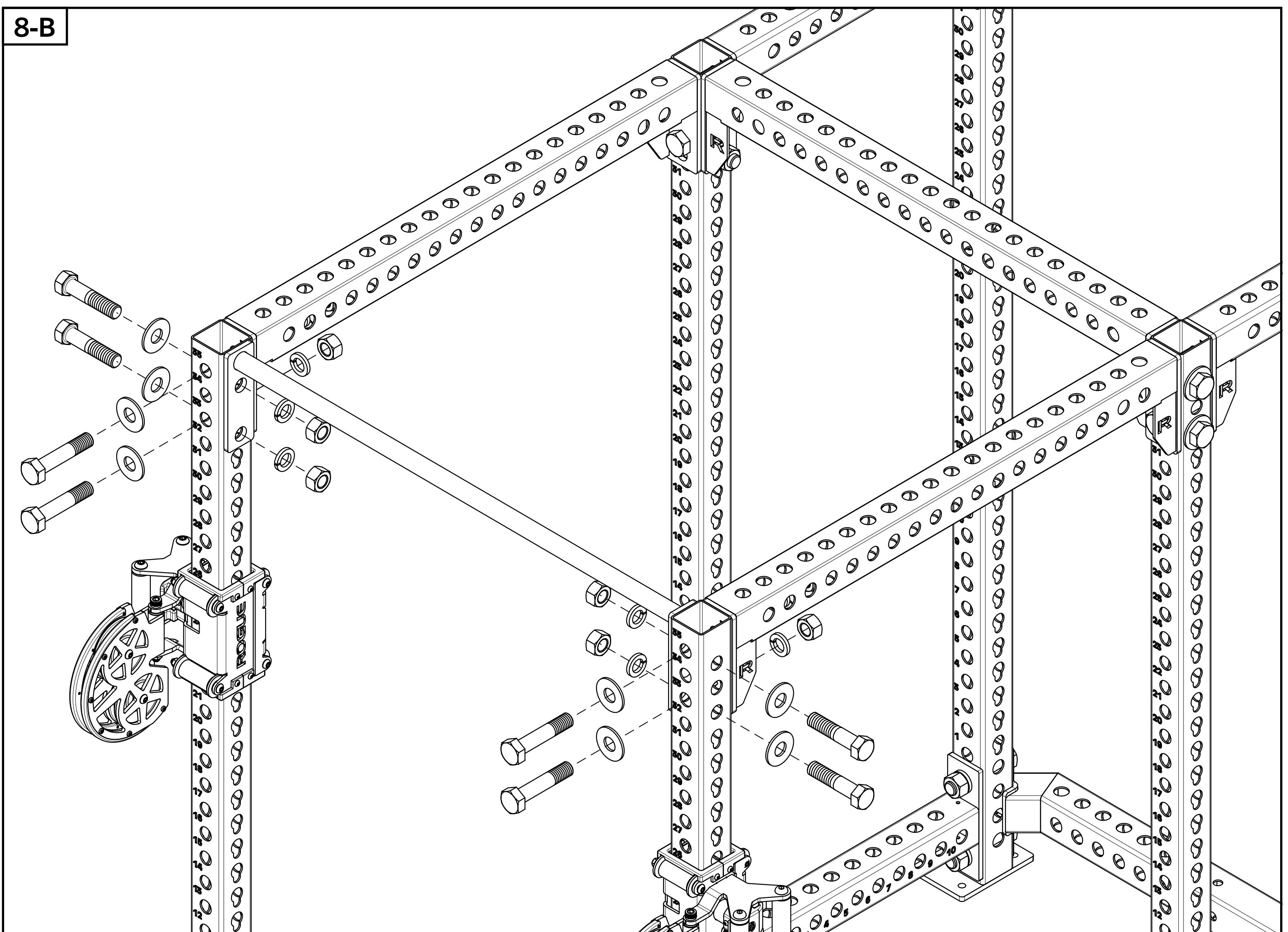
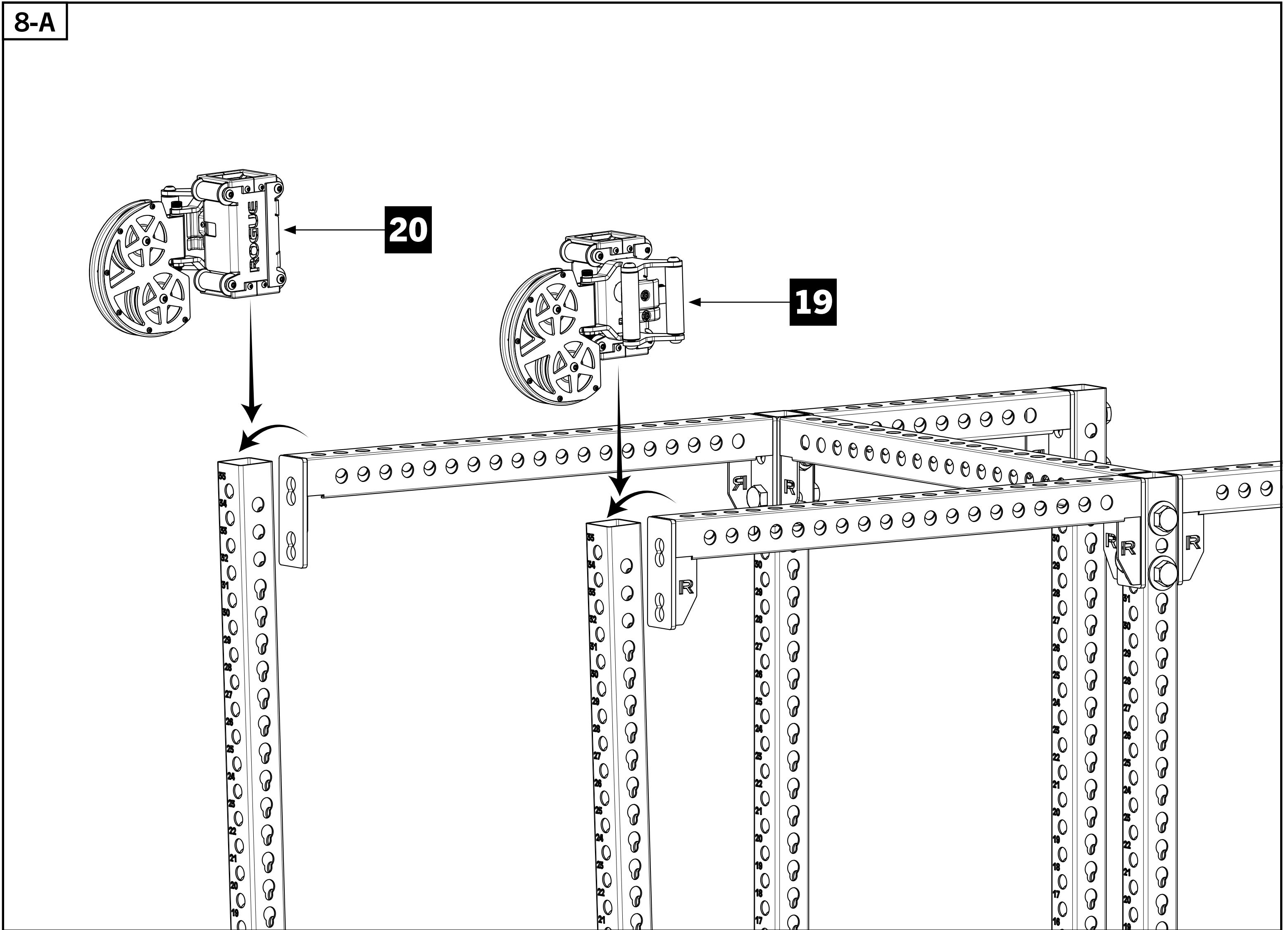

## STEP 9

### Tools Required:

- 7/32" Allen Key, 9/16" Wrench
- Swivel Trolleys [19,20] need to be calibrated for your specific rack.
- Keeping the Swivel Trolleys locked in place, tighten the Button Head Screws shown in **9-A** using 7/32" Allen Key until looseness or "wobble" is gone.

- Unlock pop pins and roll Trolleys up and down Upright several inches to feel tightness. If wobble persists, tighten the Screws in **9-A** again. If any friction is felt, Trolleys are too tight and Screws should be loosened a quarter turn.
- Once calibrated, tighten both rollers on rear of Trolleys using Allen Key and Wrench.

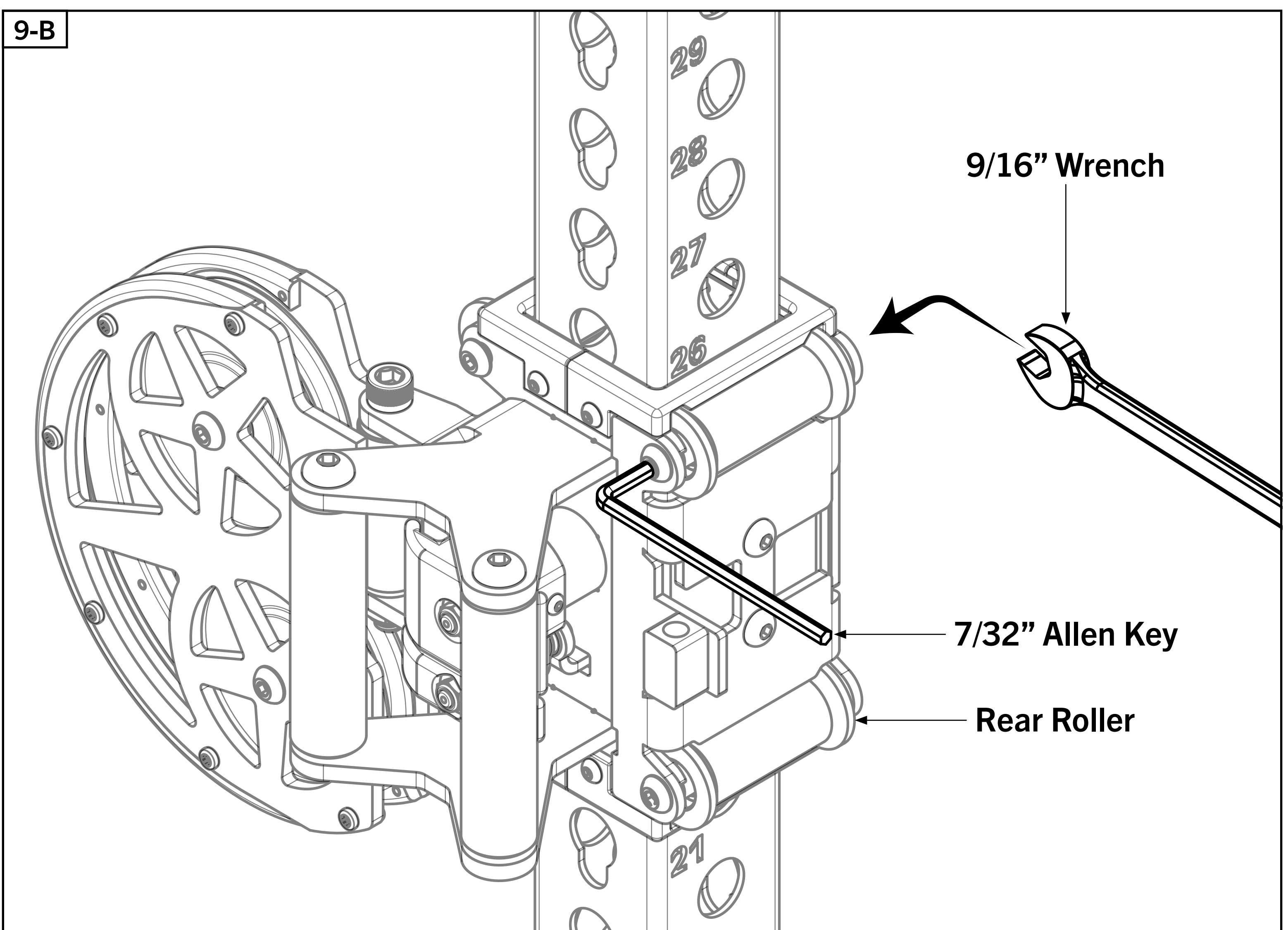
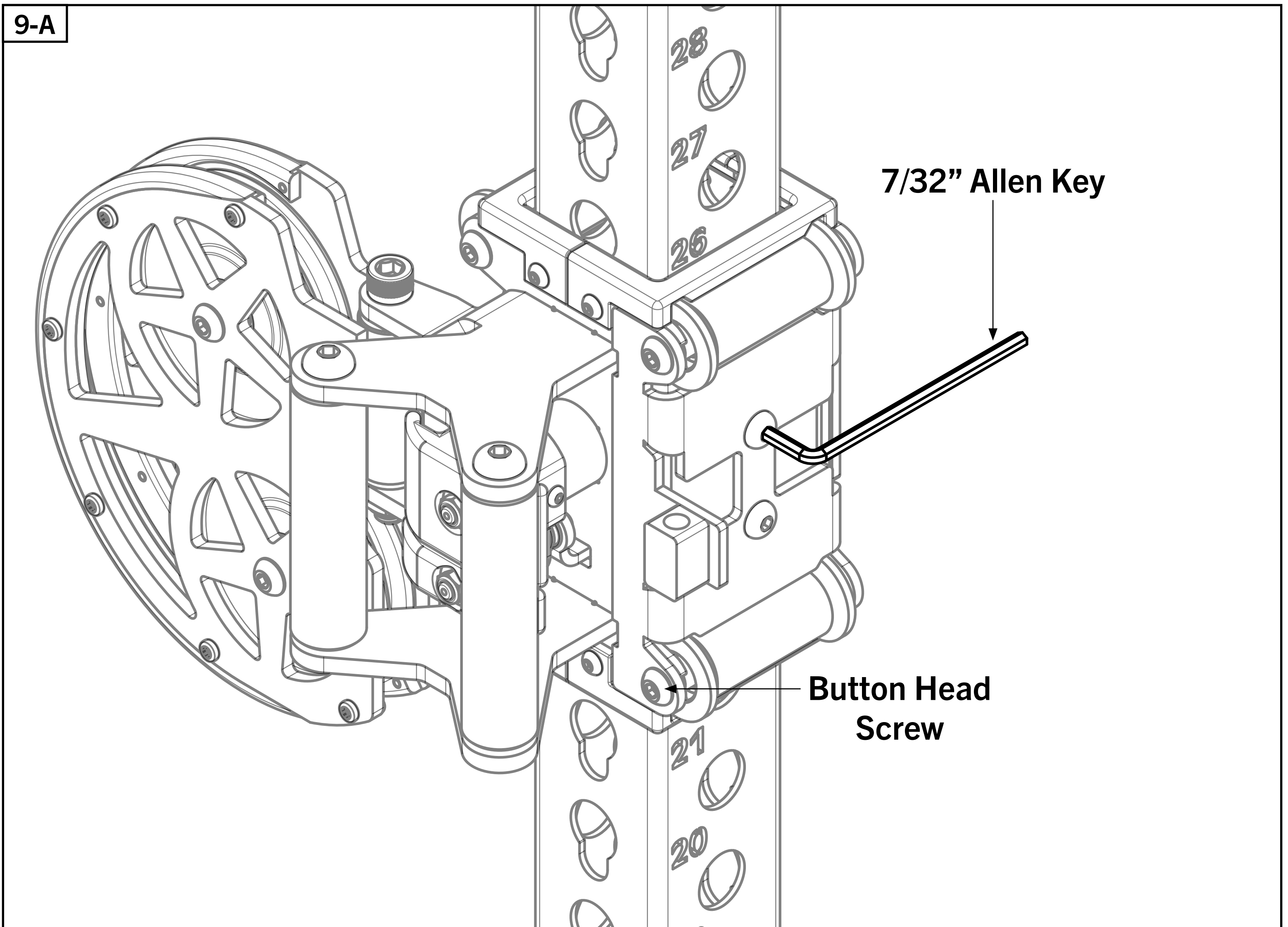

# STEP 10

- For ease of assembly, pull the pop-pin and remove Foot Catch [26] from Low Row Foot Plate Assembly [27] as shown in detail view (right).
- Attach Foot Plate Assembly [27] and Low Row Connector Plate [28] to Low Row Crossmember [18] using indicated 5/8" and 1/2" hardware below.

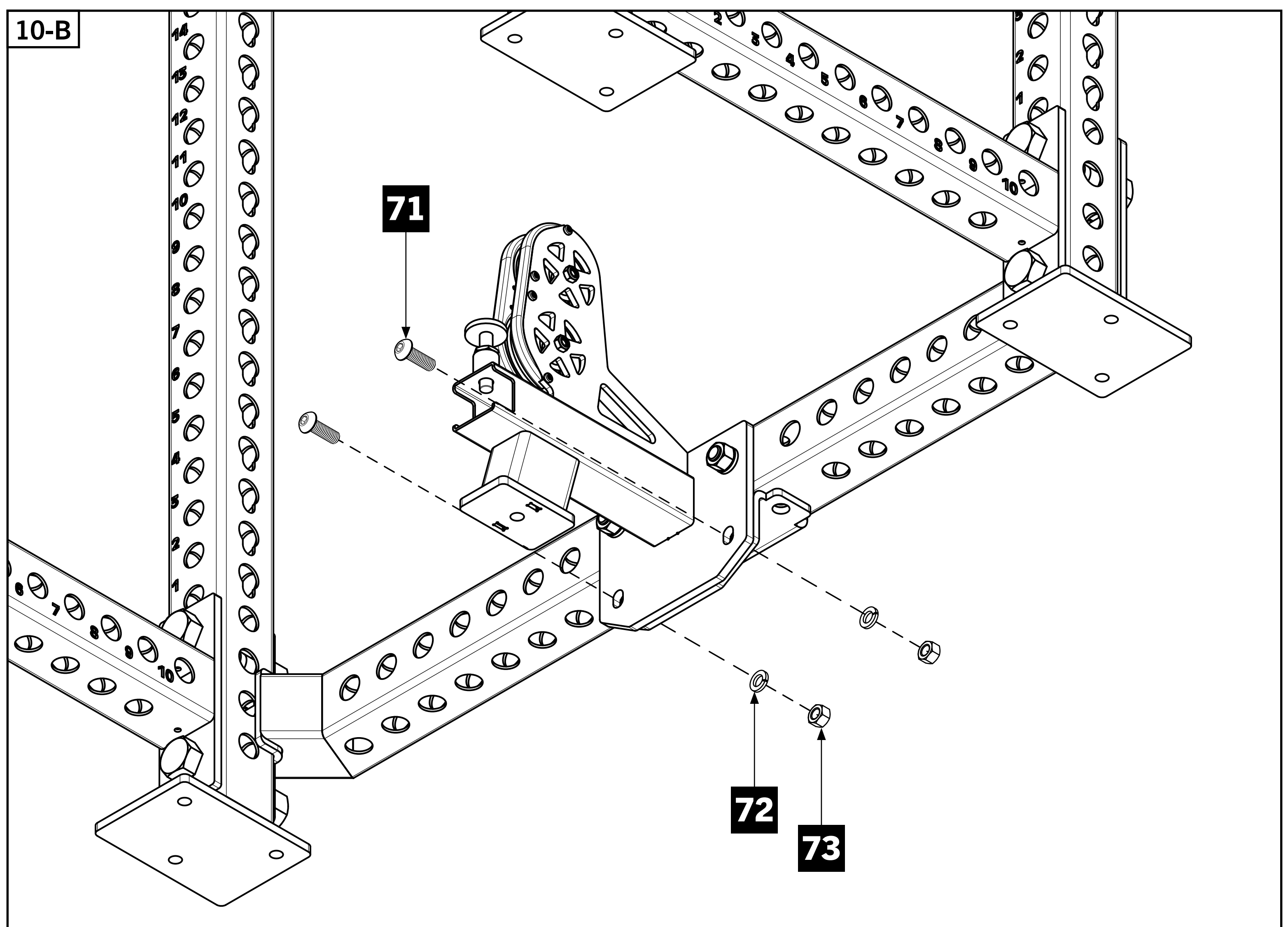
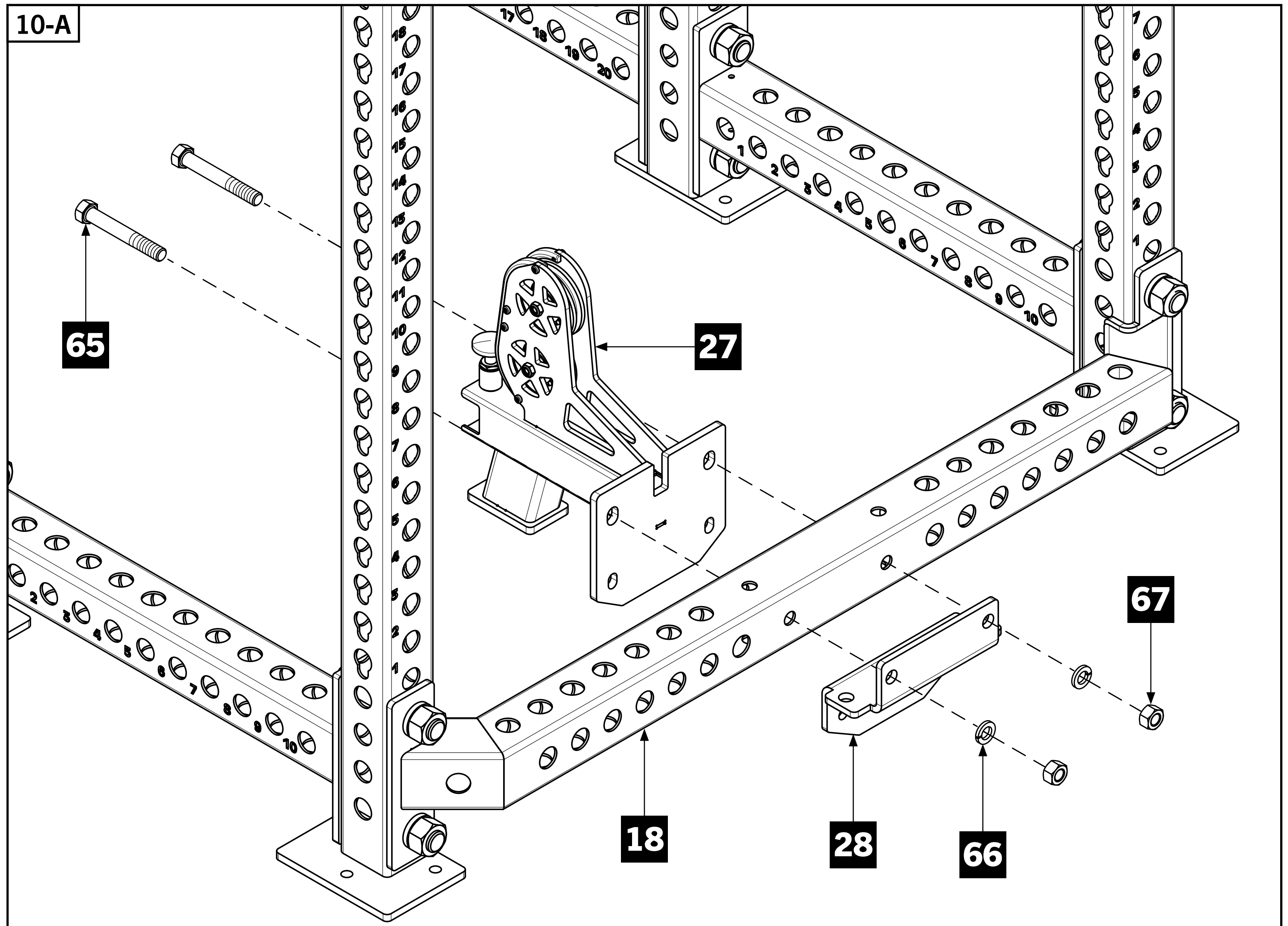
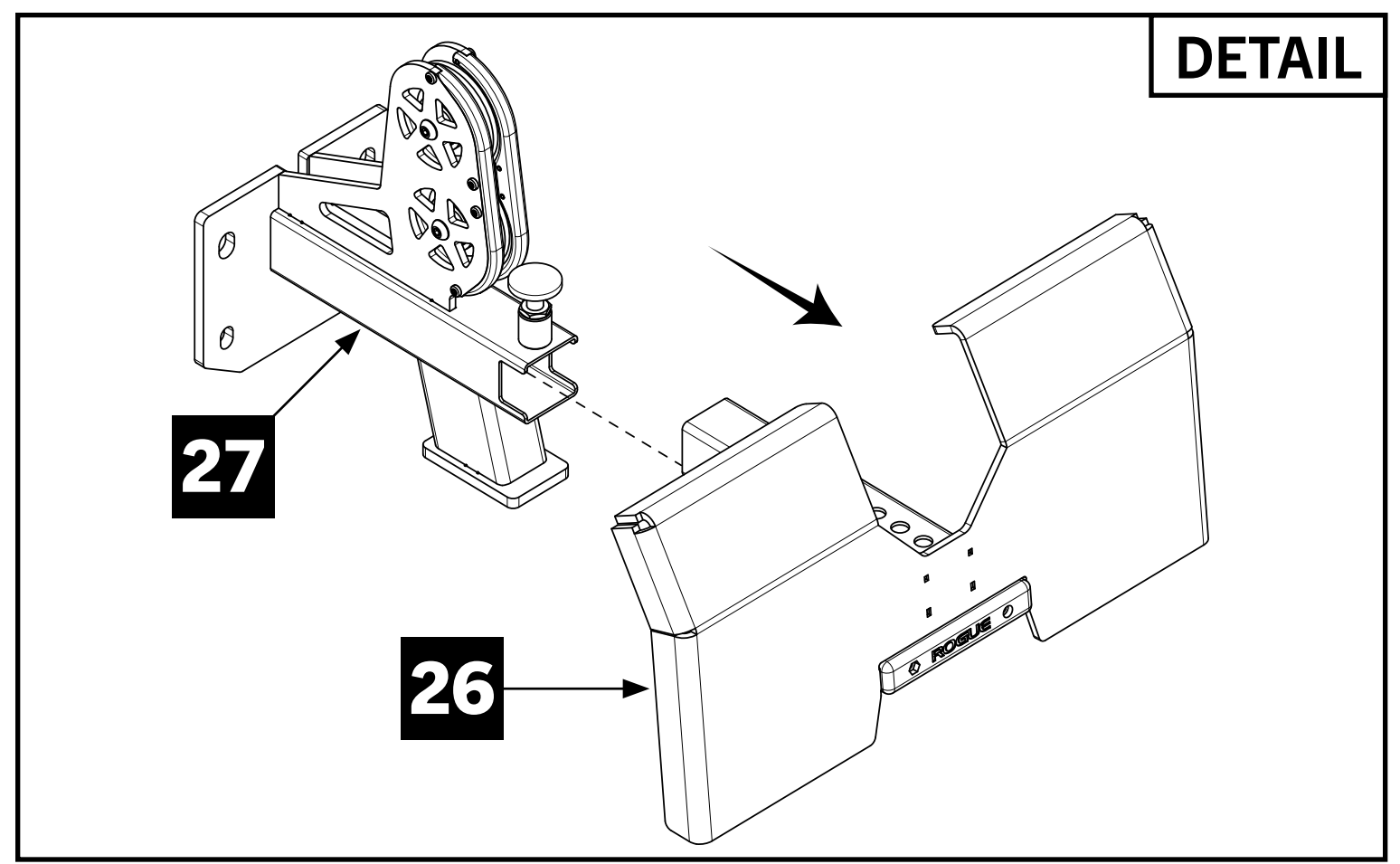

# STEP 11

## Tools Required:

- 1-1/2" Wrench
- Attach Weight Stack Shroud Brackets [78] and Bottom Weight Stack Spacers [33] to Rear Low Crossmembers [5] by using 1" x 5" Hex Bolts [60], 1" Flat Washers [62], 1" Lock Washers [63], and 1" Hex Nuts [64].
- Fully tighten 1" vertical hardware in 11-A.

- Secure Rear 3X3 Upright [17] to Low Row Crossmember by attaching 5/8" x 4-1/2" Hex Bolts [65], 5/8" Lock Washers [66], and 5/8" Hex Nuts [67].

## Note:

- Ensure notches on Bottom Weight Stack Spacers are oriented towards the back of rack.

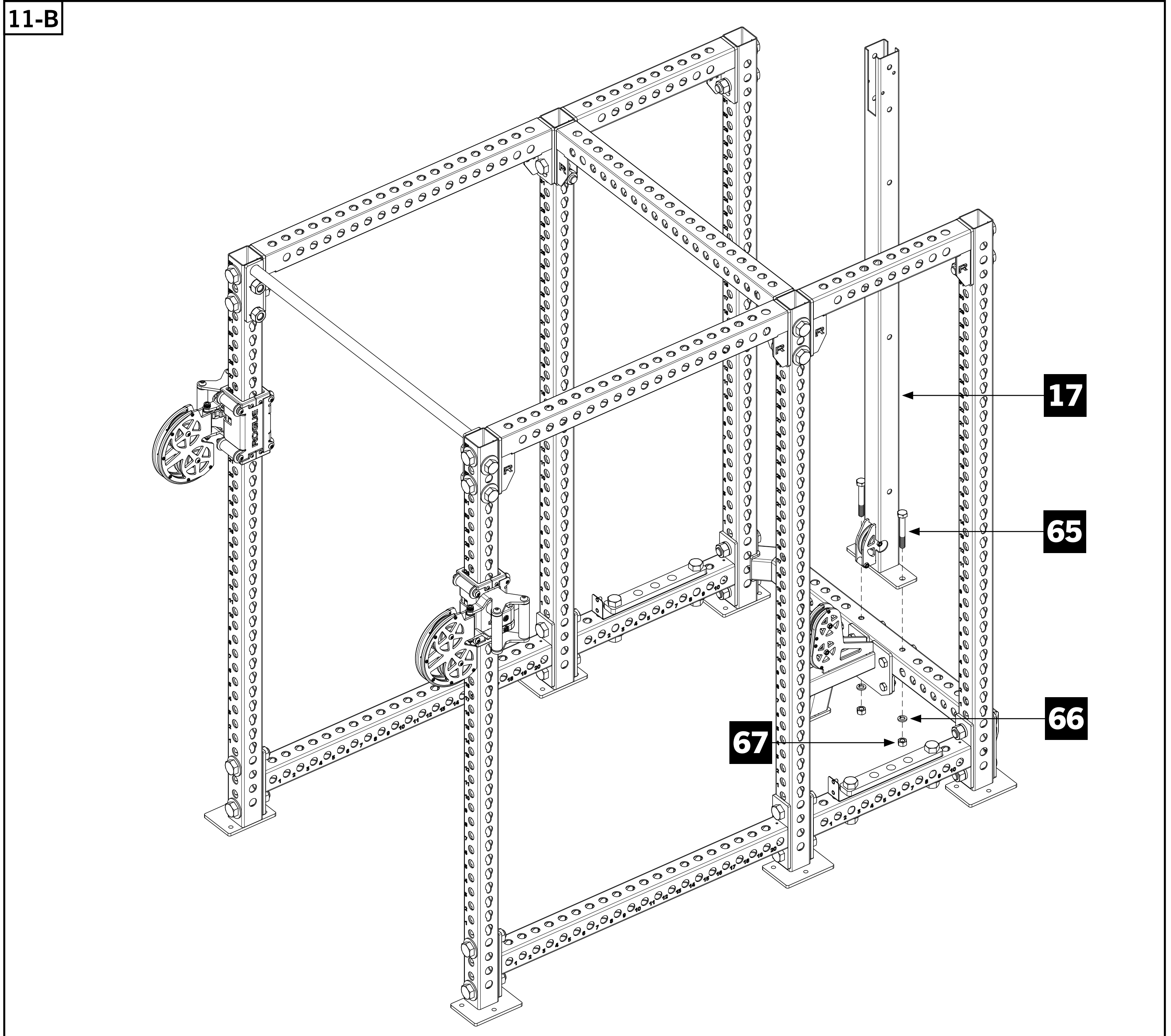
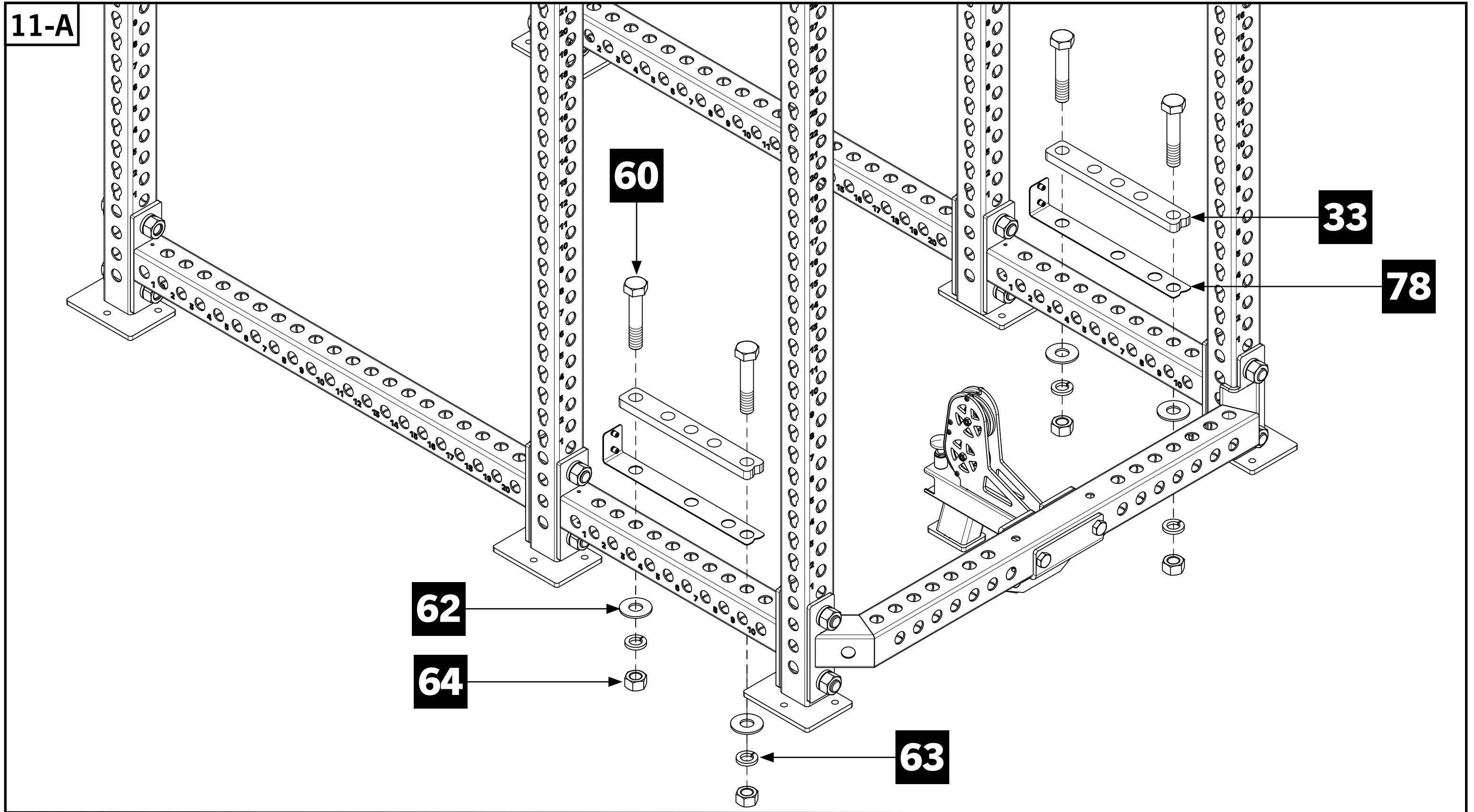

## STEP 12

- Place Weight Stack Bumpers [35] over outer 1" holes on the Weight Stack Spacer and insert Guide Rods [29] until they rest on top of the Rear Low Crossmember.

### Note:

- Allow guide rods to angle outward while completing weight stack assembly on the following steps.

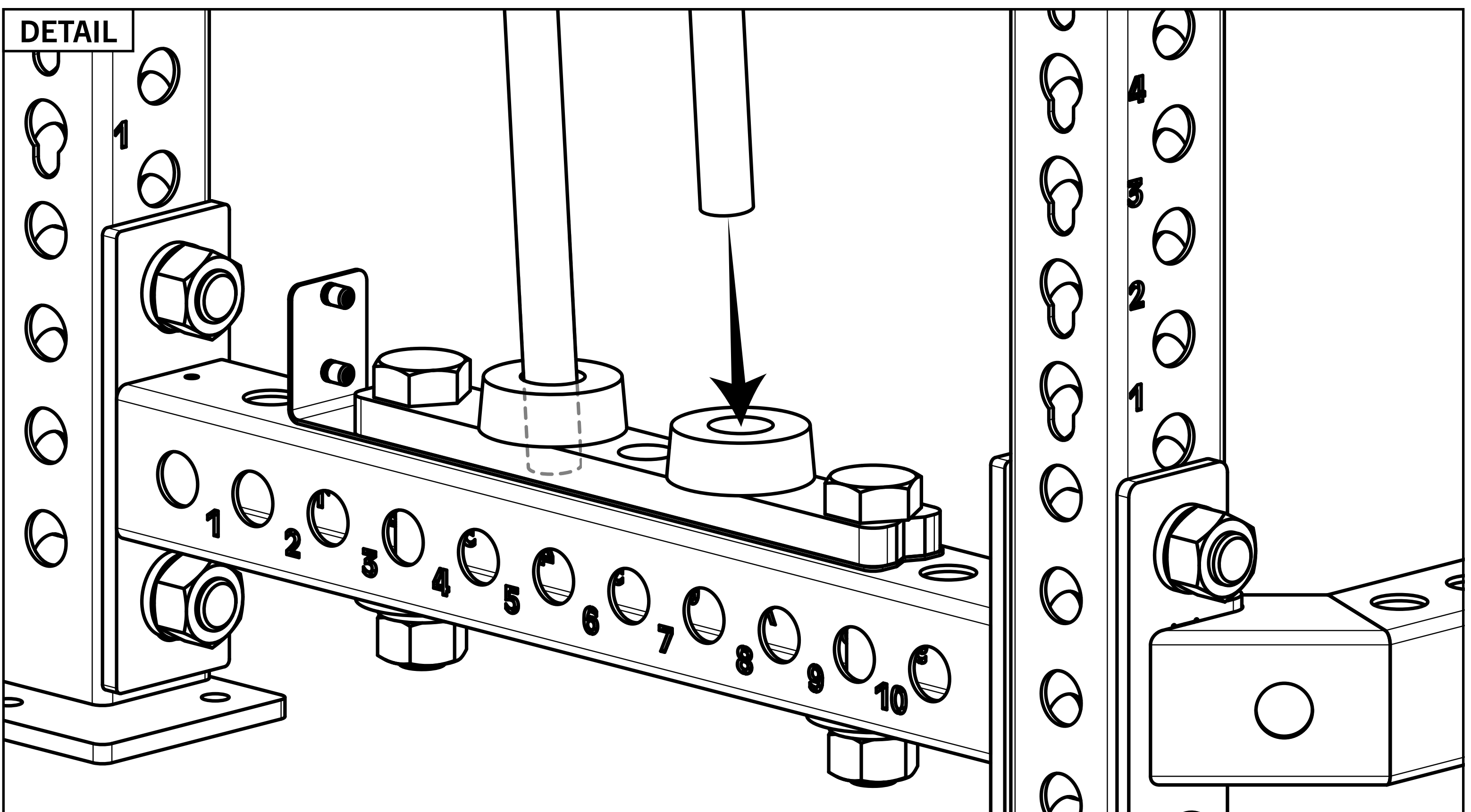
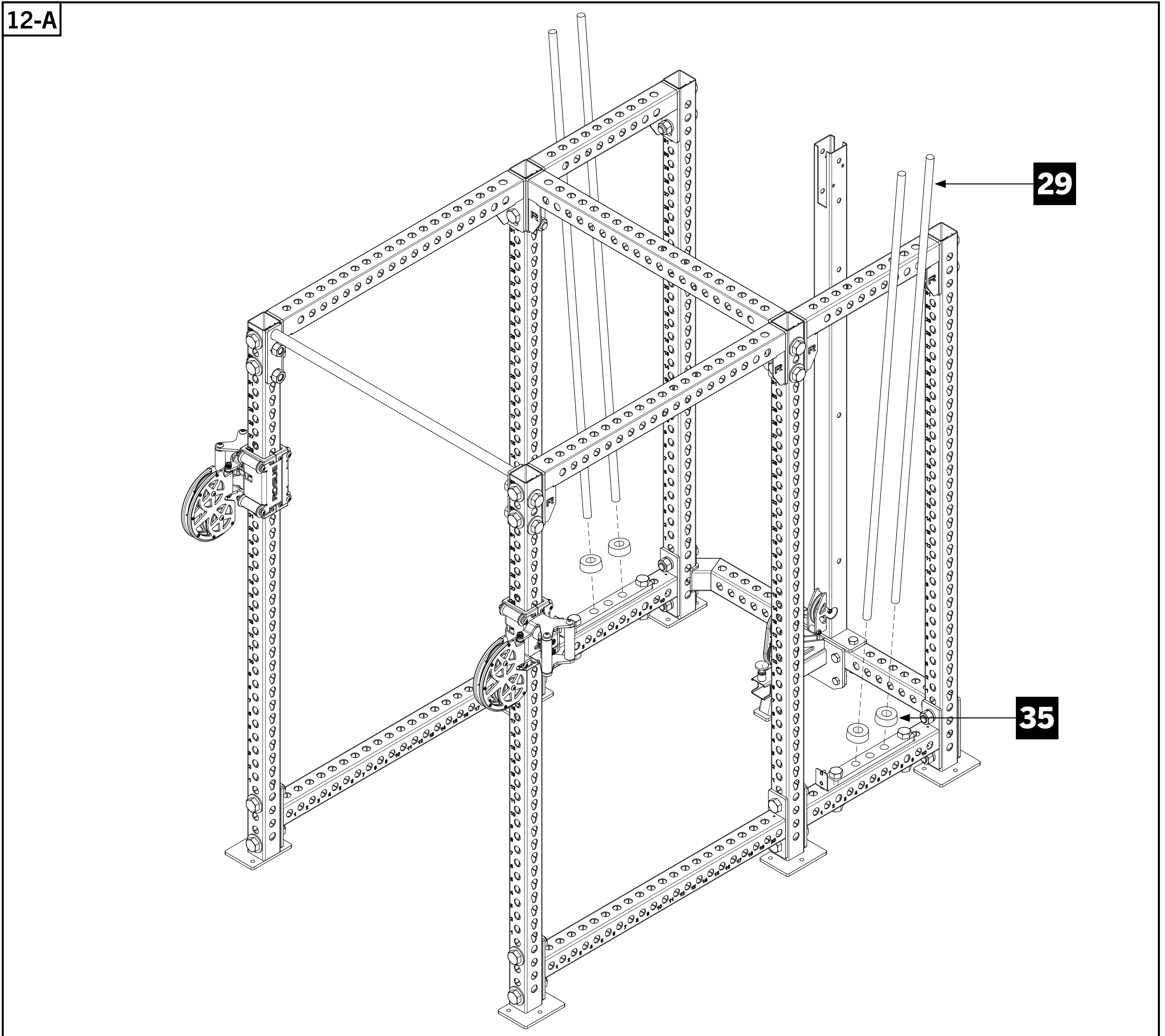

# STEP 13

## Note:

- This step is best accomplished with two or three people.
- One at a time, carefully stack all included 10LB Weight Stack Plates [31] down the Guide Rods [29], ensuring not to drop them.

- Once 28 weights are stacked on each side, slide the Weight Stack Stem [30] down the Guide Rods until resting on top of weight stack.
- Ensure '20LB' Weight Stack Stickers on the top plate of Weight Stack Stems are both facing inward towards the middle of the rack.

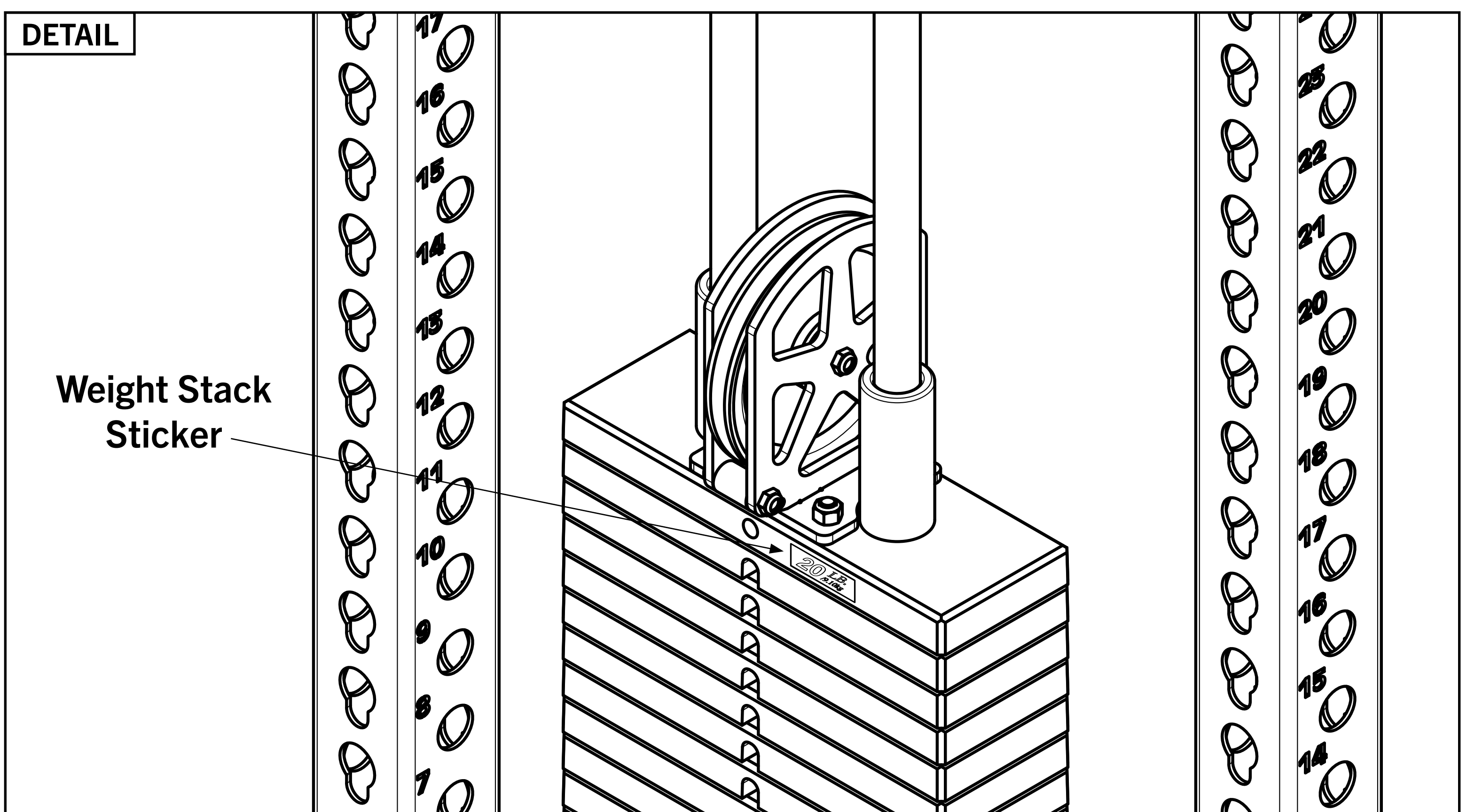
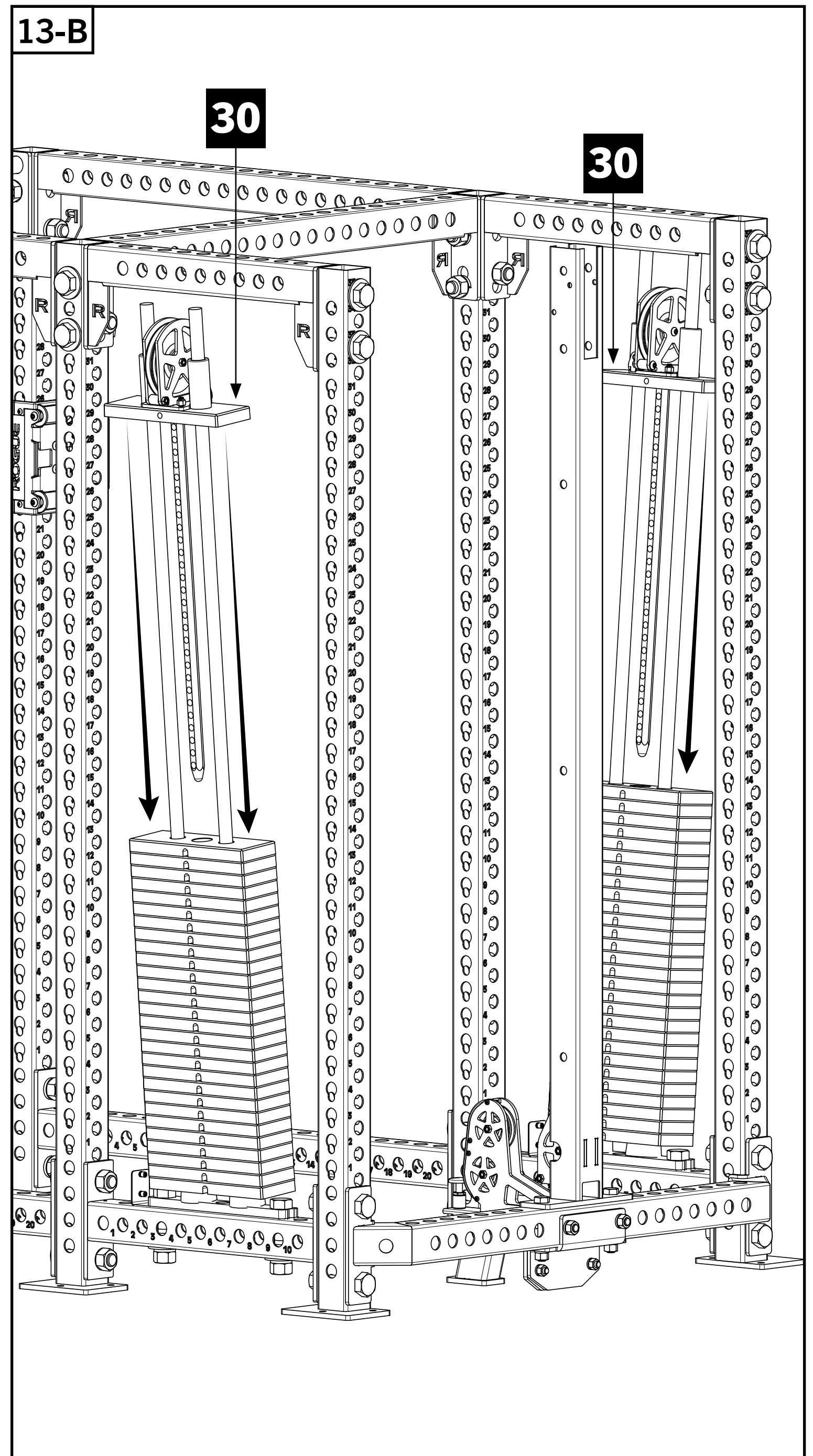
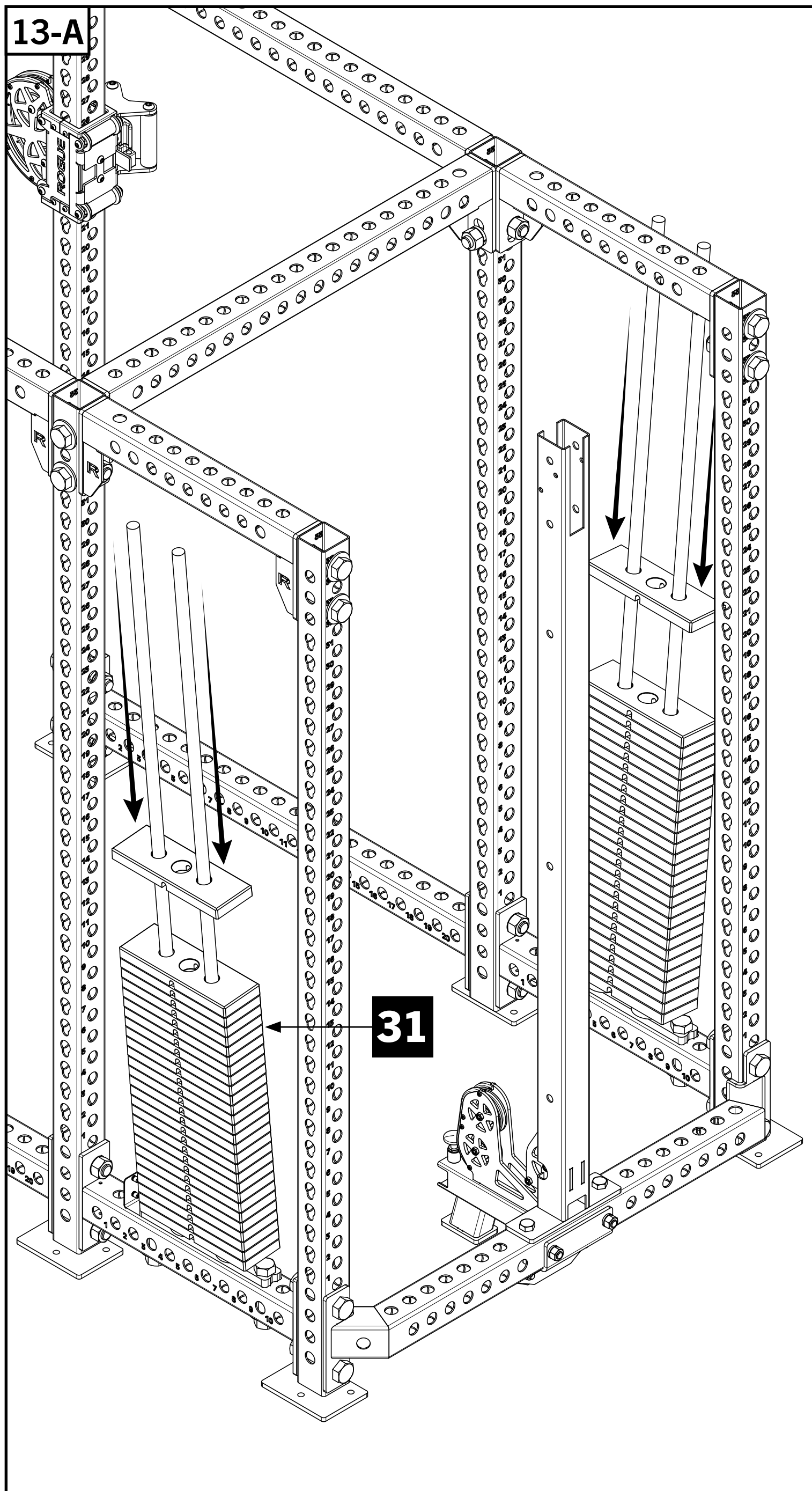

# STEP 14

- Slide Top Weight Stack Spacers [34] on top of guide rods with notches oriented towards the rear of rack.
- Position Guide Rods vertically. Slide in the Weight stack Shroud Brackets above the Guide Rods. Attach components to Rear Top Crossmembers using 1" Shoulder Bolts - Female and Male [58,59].

- Attach Weight Stack Pulley Top Bumpers [36] through center holes on Top Weight Stack Spacers using 1/2" x 4-1/2" Socket Head Screws [68], 1/2" Flat Washers [69], and 1/2" Thin Nylock Nuts [70].
- Fully tighten the 1/2" hardware and the 1" Shoulder Bolts.

**Note:**

- Shroud Bracket [79] only included if shroud kit was purchased.

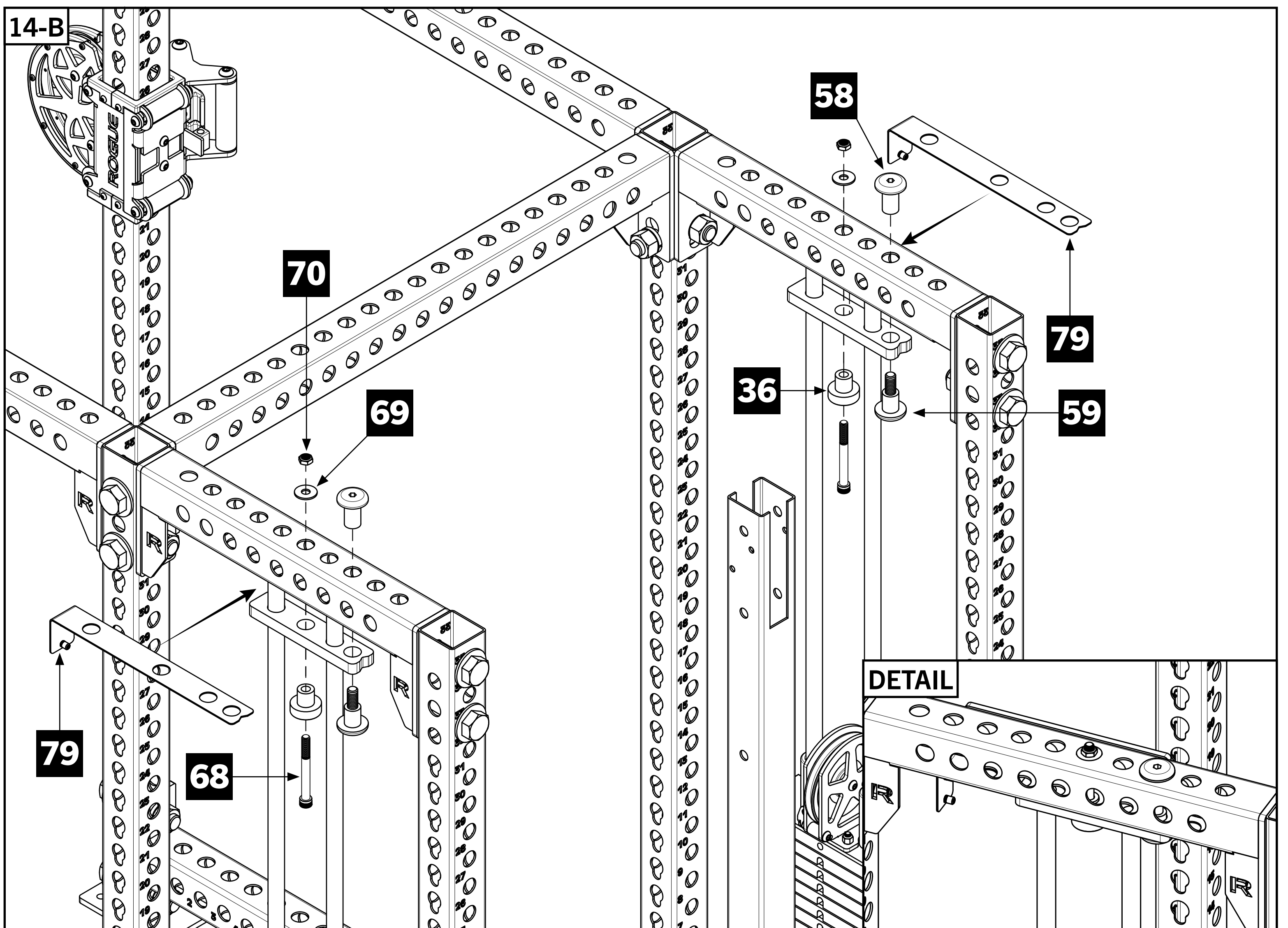
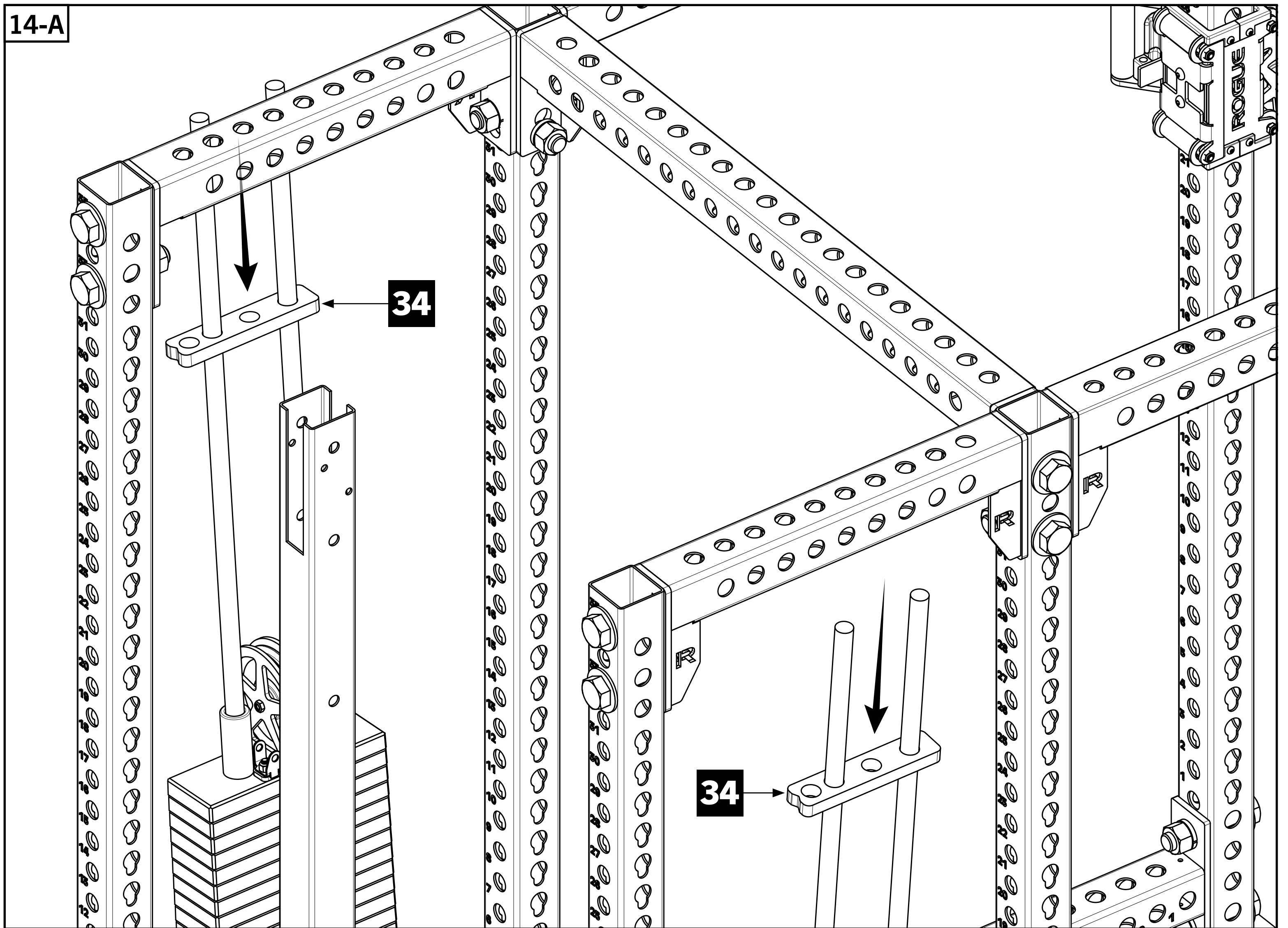

# STEP 15

- Bolt Lat Pulldown Pulley Bracket [25], and Top Center Crossmember [21] to Top Crossmember using 1" x 5" Hex Bolts [60], 1" Lock Washers [63], and 1" Hex Nuts [64] as shown in **15-A**.

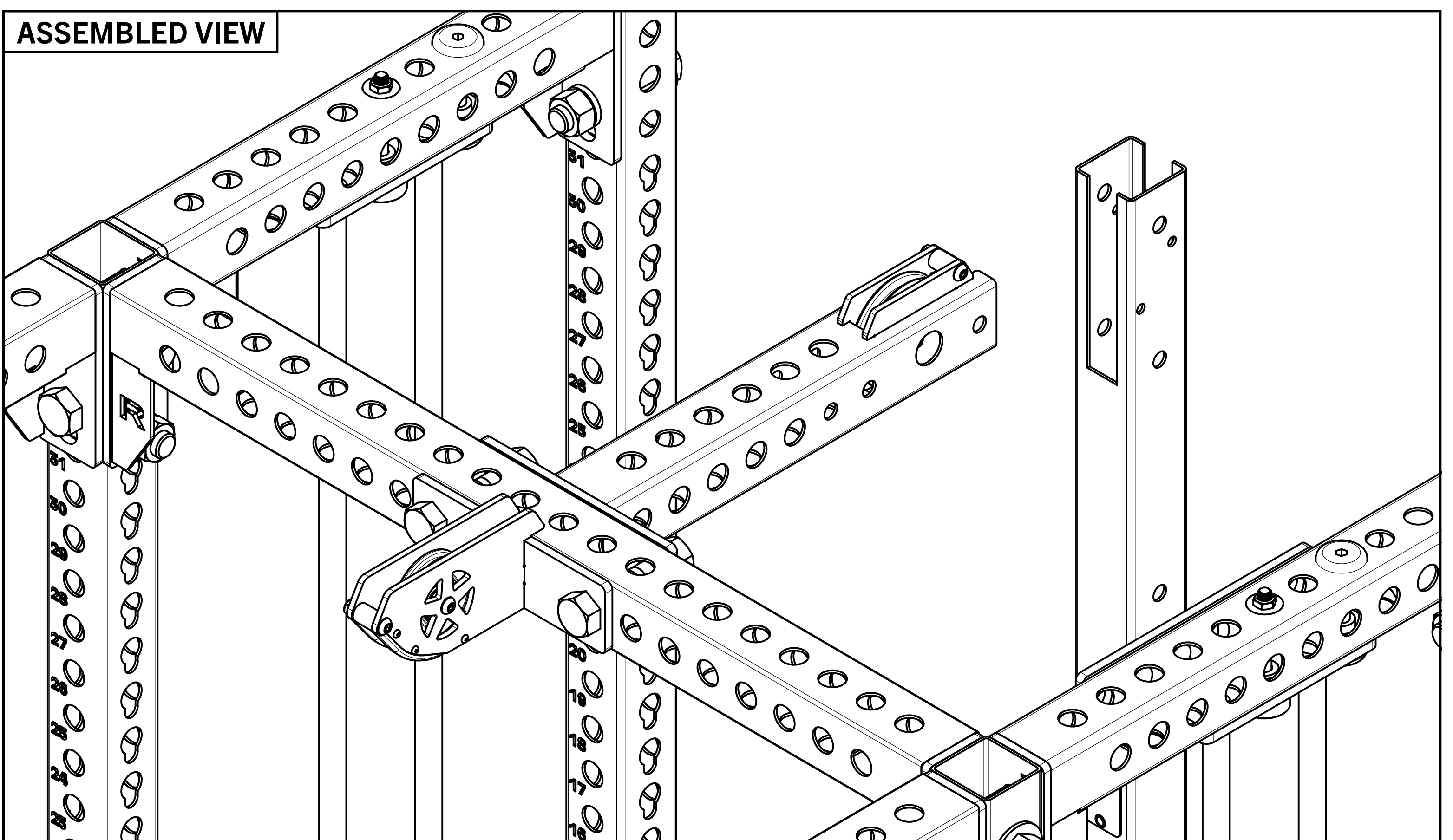
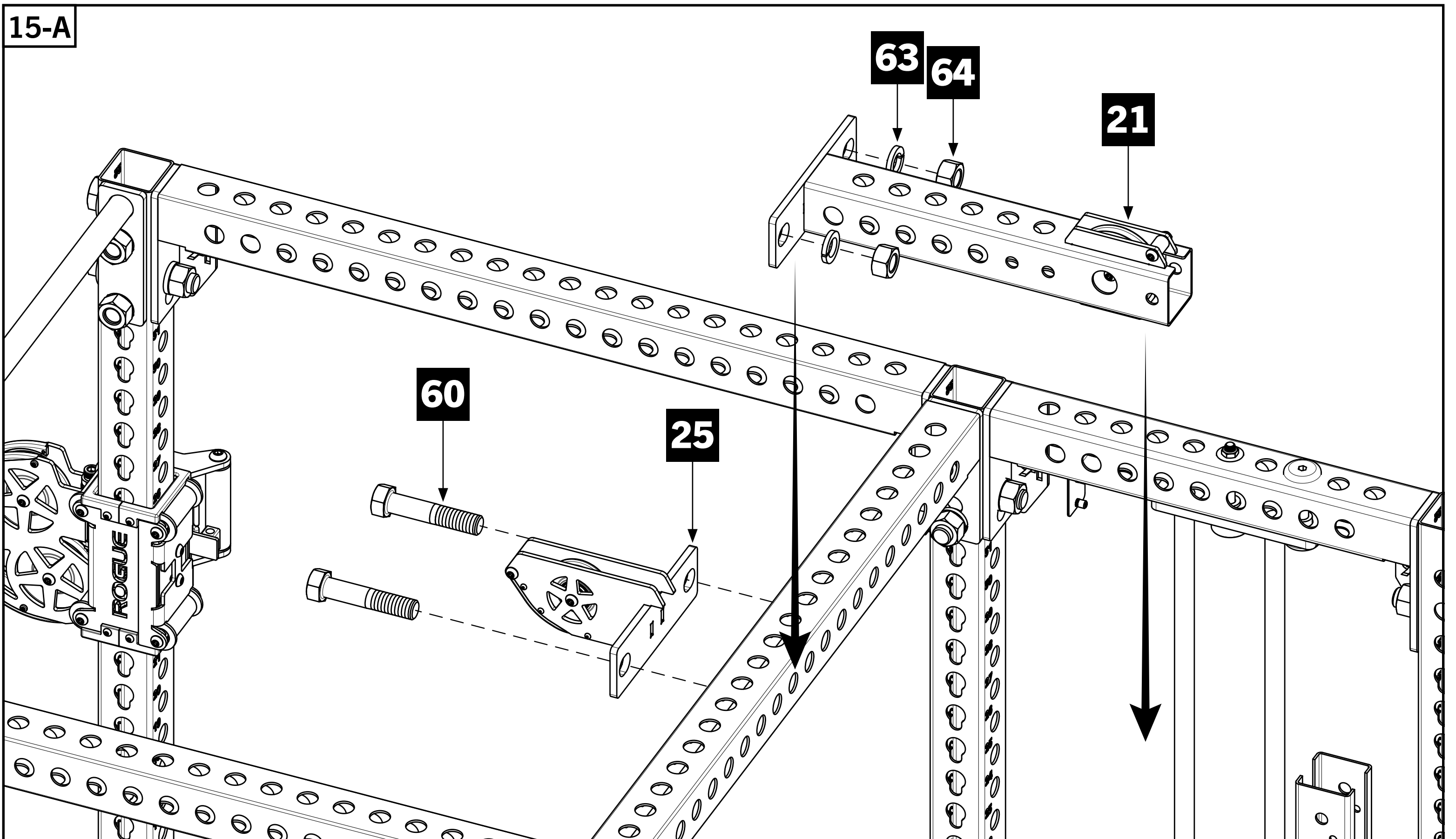
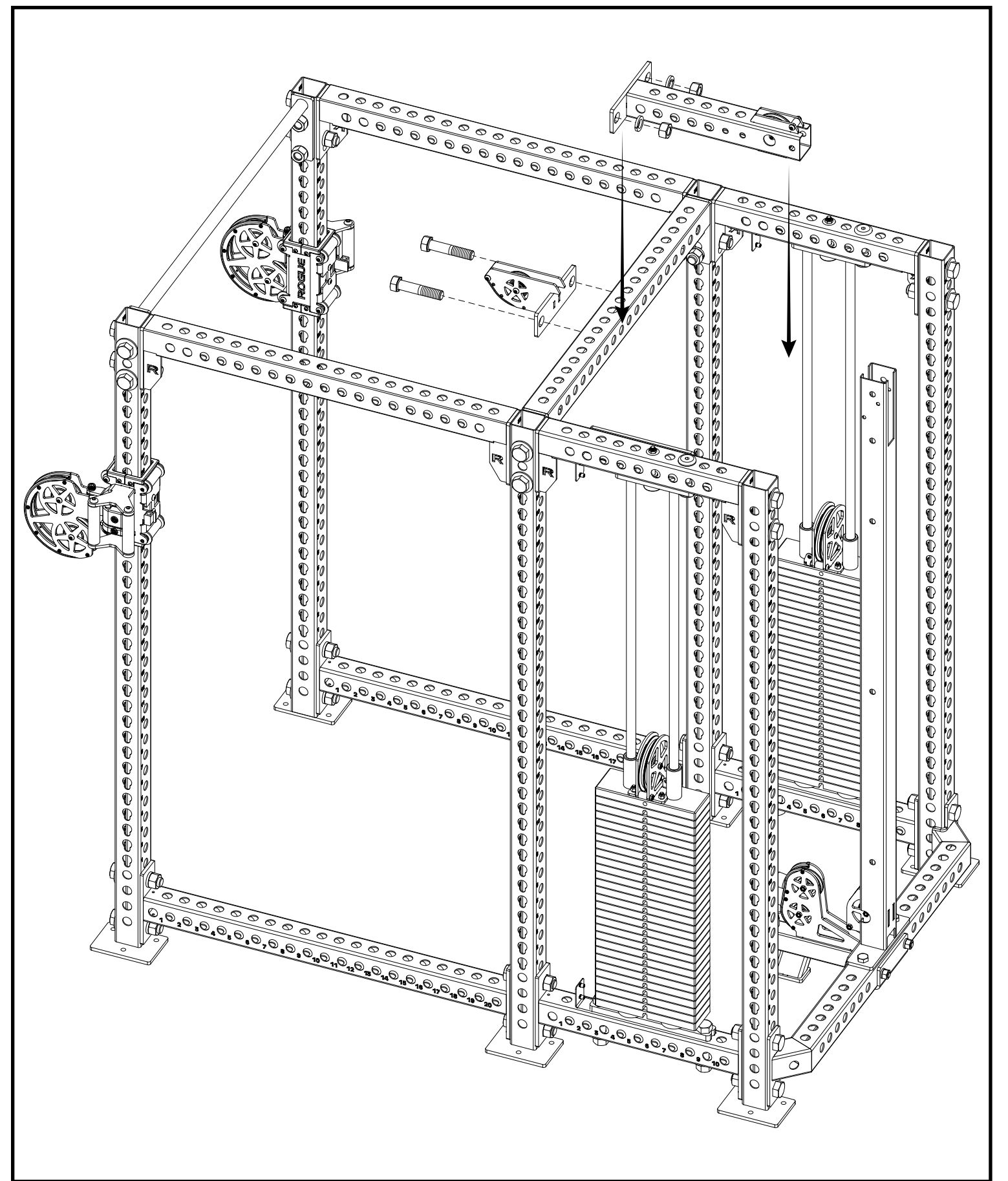

# STEP 16

- Attach Top Rear Angle Crossmember - RH and Top Rear Side Pulley Assembly - RH in position shown using 1" x 5" Hex Bolts, 1" x 3/8" Pulley Bracket Spacers, 1" Lock Washers, and 1" Hex Nuts.
- Attach Top Rear Angle Crossmember - LH and Top Rear Side Pulley Assembly - LH in position shown using 1" x 5" Hex Bolts, 1" x 3/8" Pulley Bracket Spacers, 1" Lock Washers, and 1" Hex Nuts.
- Ensure rear plates of Top Rear Angle Crossmembers are placed inside of slot of the Rear Upright as shown in **DETAIL**.

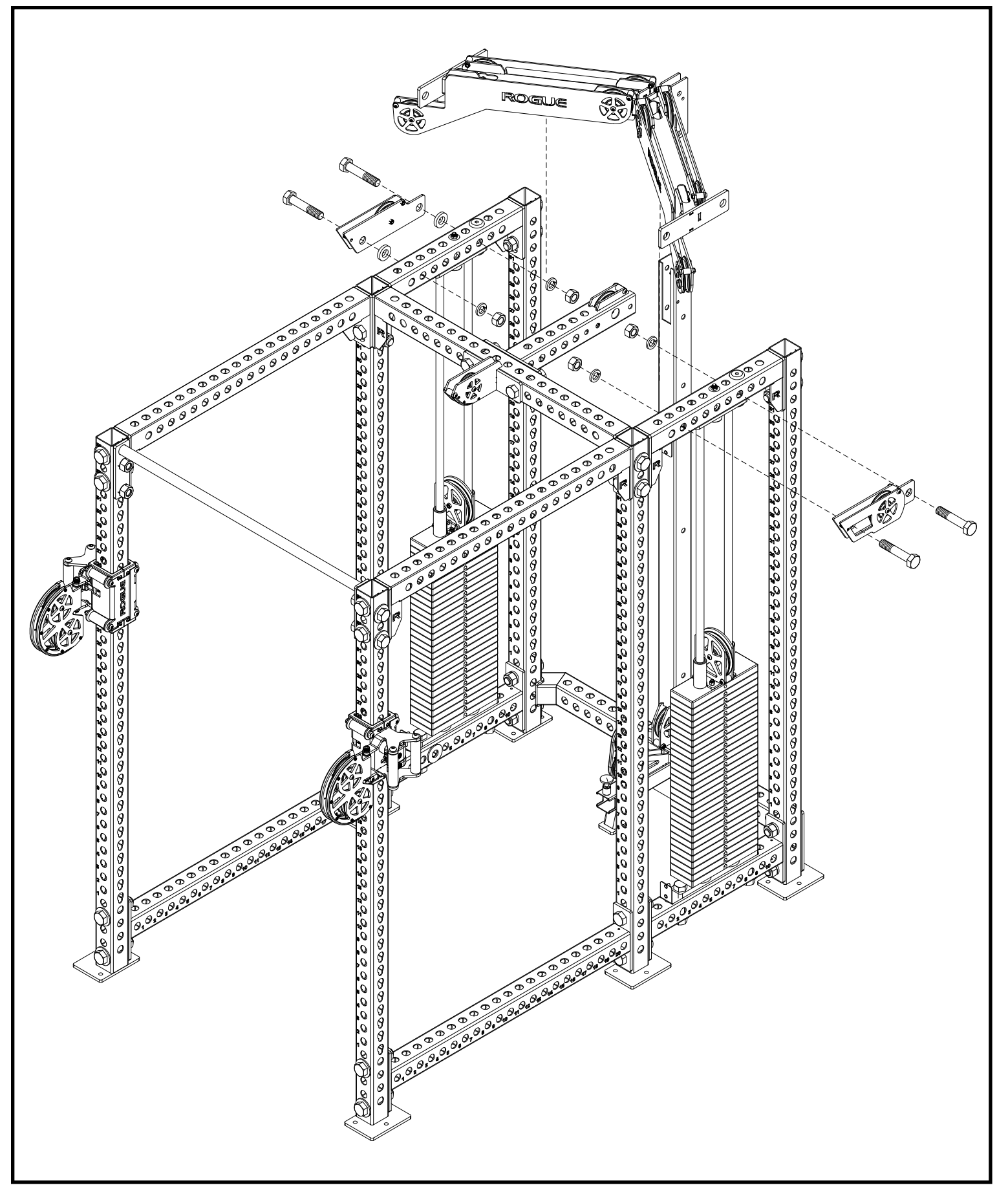

16-A

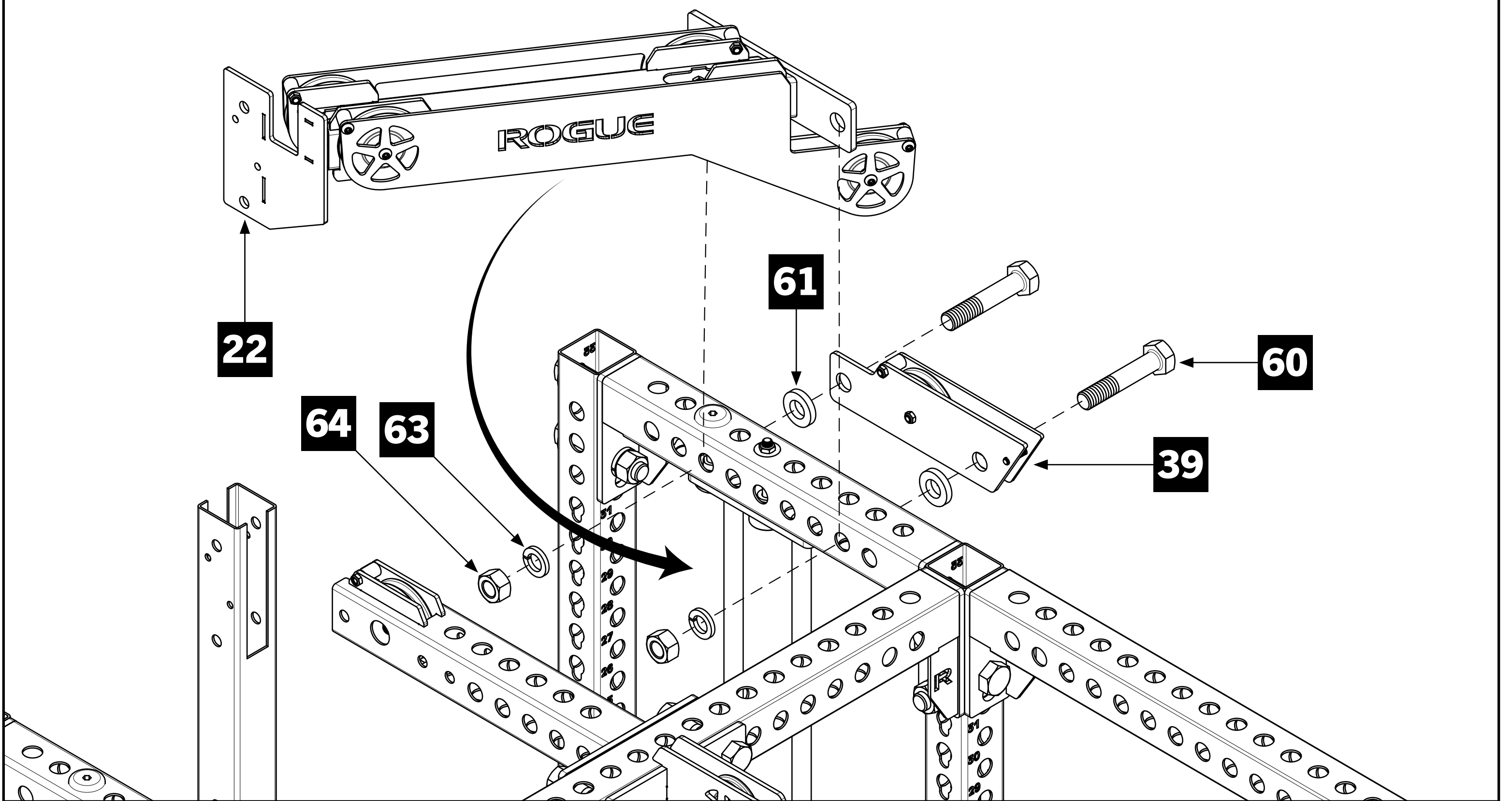

16-B

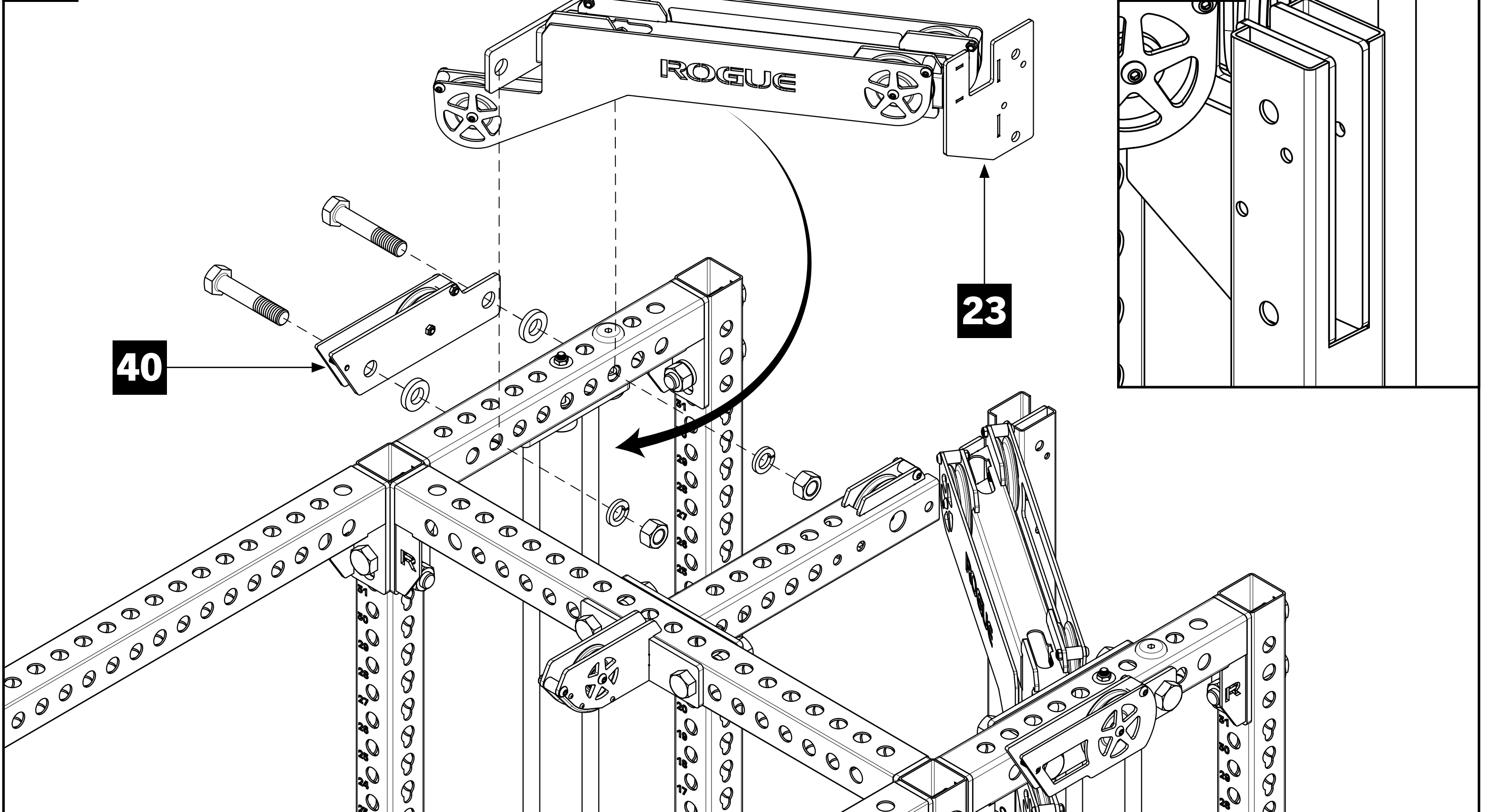

# STEP 17

- Secure 4.5" Pulley [48] and 3/4" x 1" Cable Retainer [49] inside Rear 3X3 Upright using 3/8" x 3-1/2" Button Head Screws [74] and 3/8" Thin Nylock Nuts [75] through the indicated holes.

- Bolt Connector Plates [24] to Top Center Crossmember [21] and Rear 3X3 Upright using 5/8" x 4-1/2" Hex Bolts [65], 5/8" Lock Washers [66], and 5/8" Hex Nuts [67].

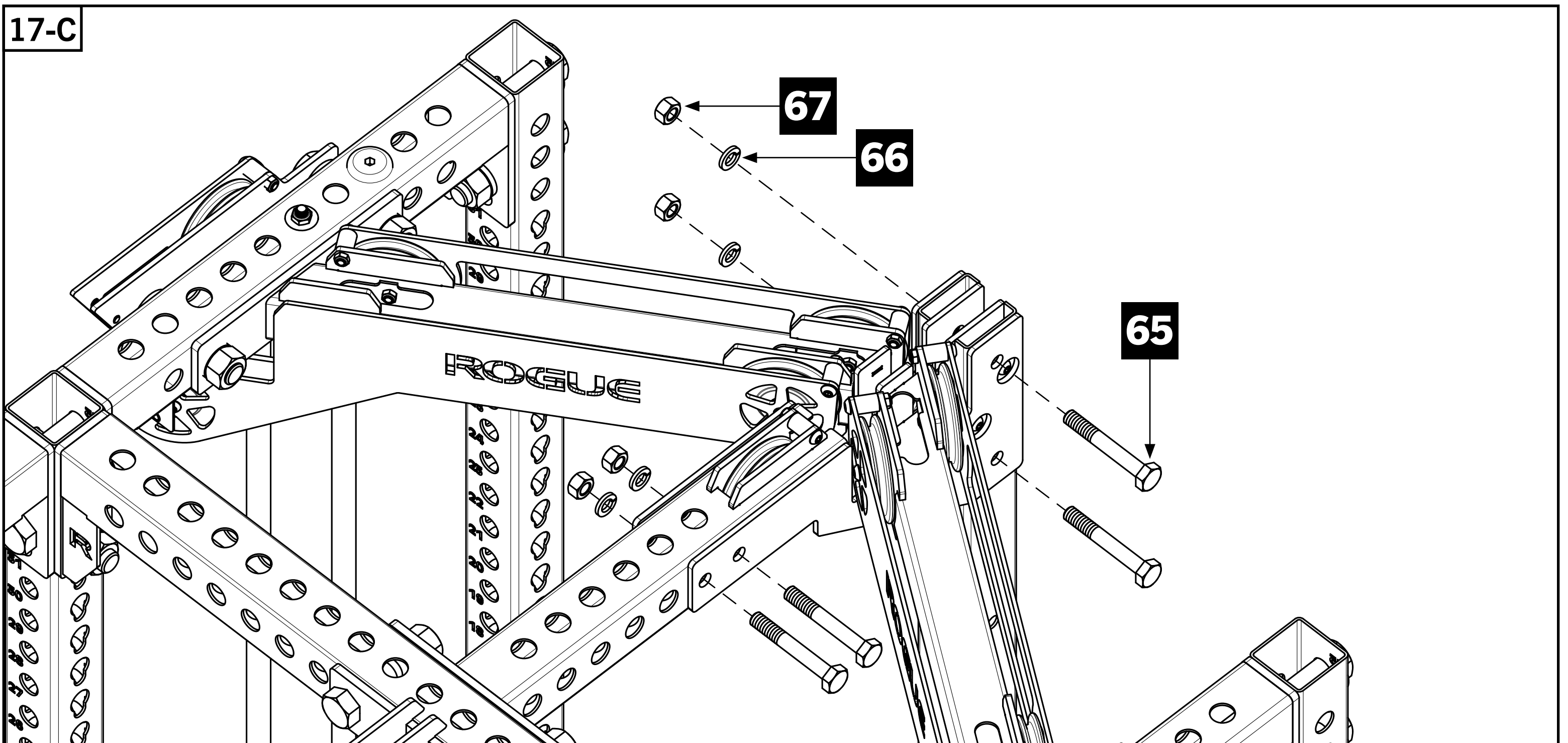
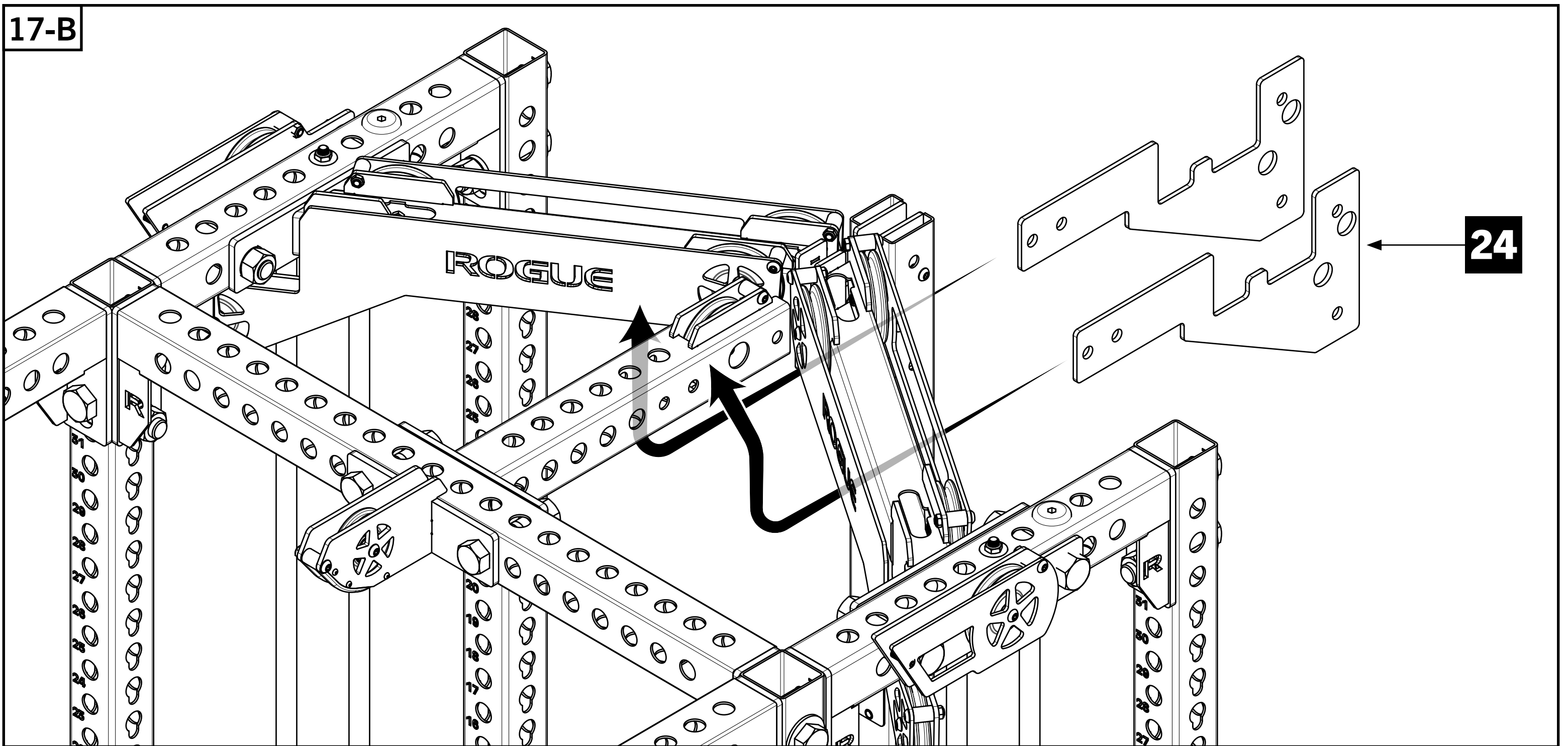
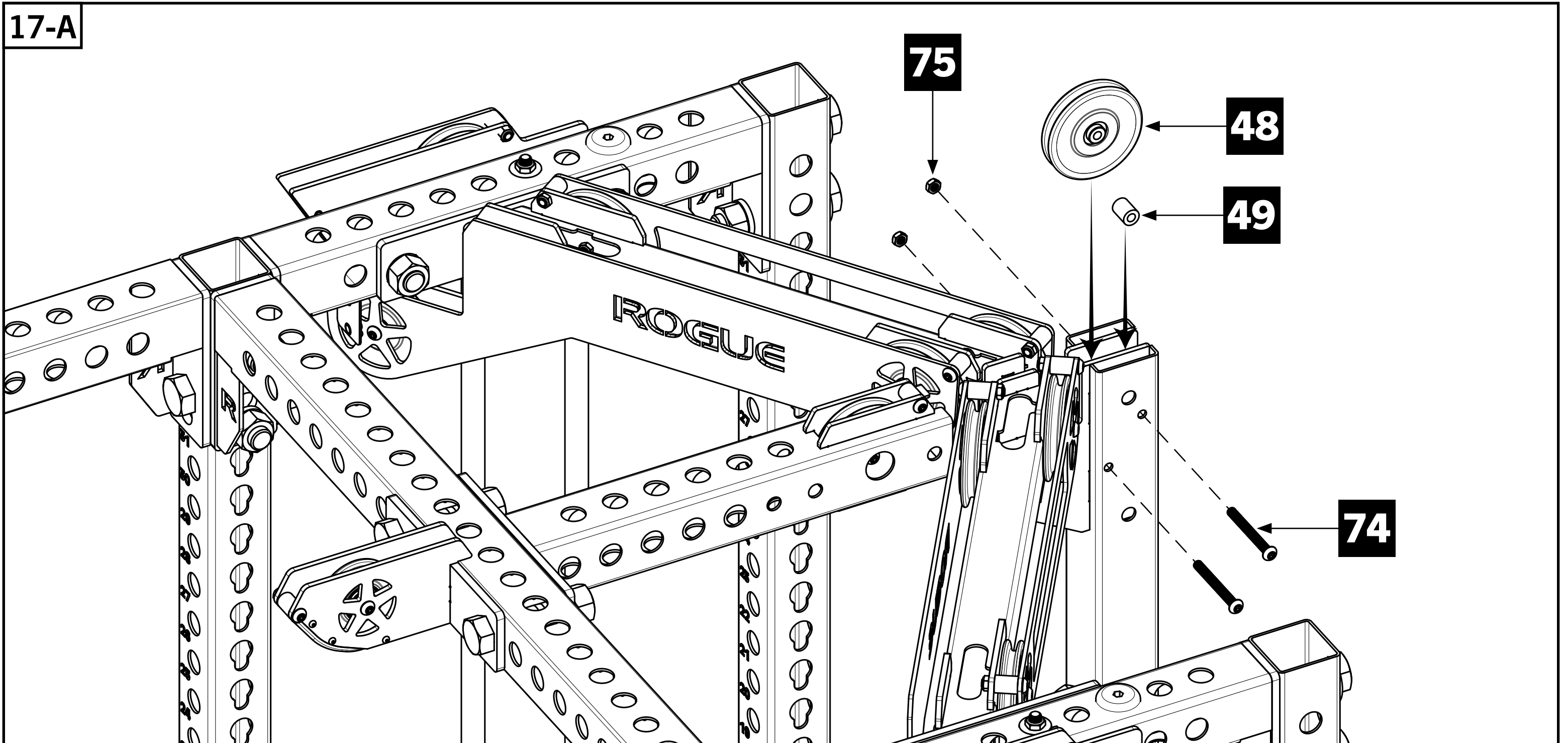

# STEP 18

- Bolt Top Front Side Pulley Assembly - RH [41] and -LH [42] to the Front Top Crossmembers using 1" x 5" Hex Bolts [60], 1" x 3/8" Pulley Bracket Spacers [61], 1" Flat Washers [62], 1" Lock Washers [63], 1" Lock Washers [63], and 1" Hex Nuts [64] as shown.

- **!** 43" Front Top Crossmember is shown. The Top Front Side Pulley Assembly holes utilized will depend on length of your Front Crossmembers. Use the diagram below to determine which holes to use.

**Note:**

- Bolt hardware through the 4th and 6th holes on your Front Top Crossmembers [2] regardless of crossmember length.

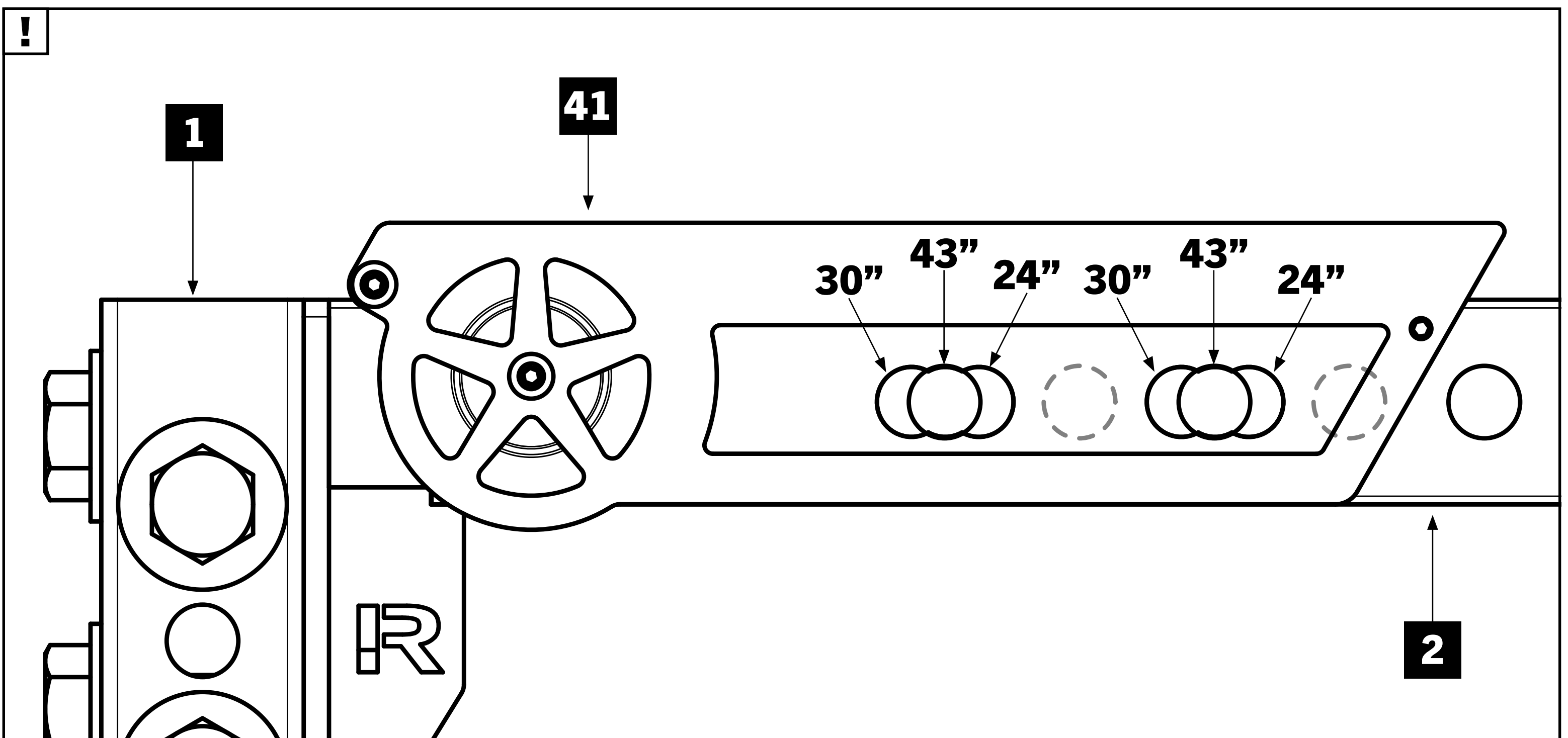
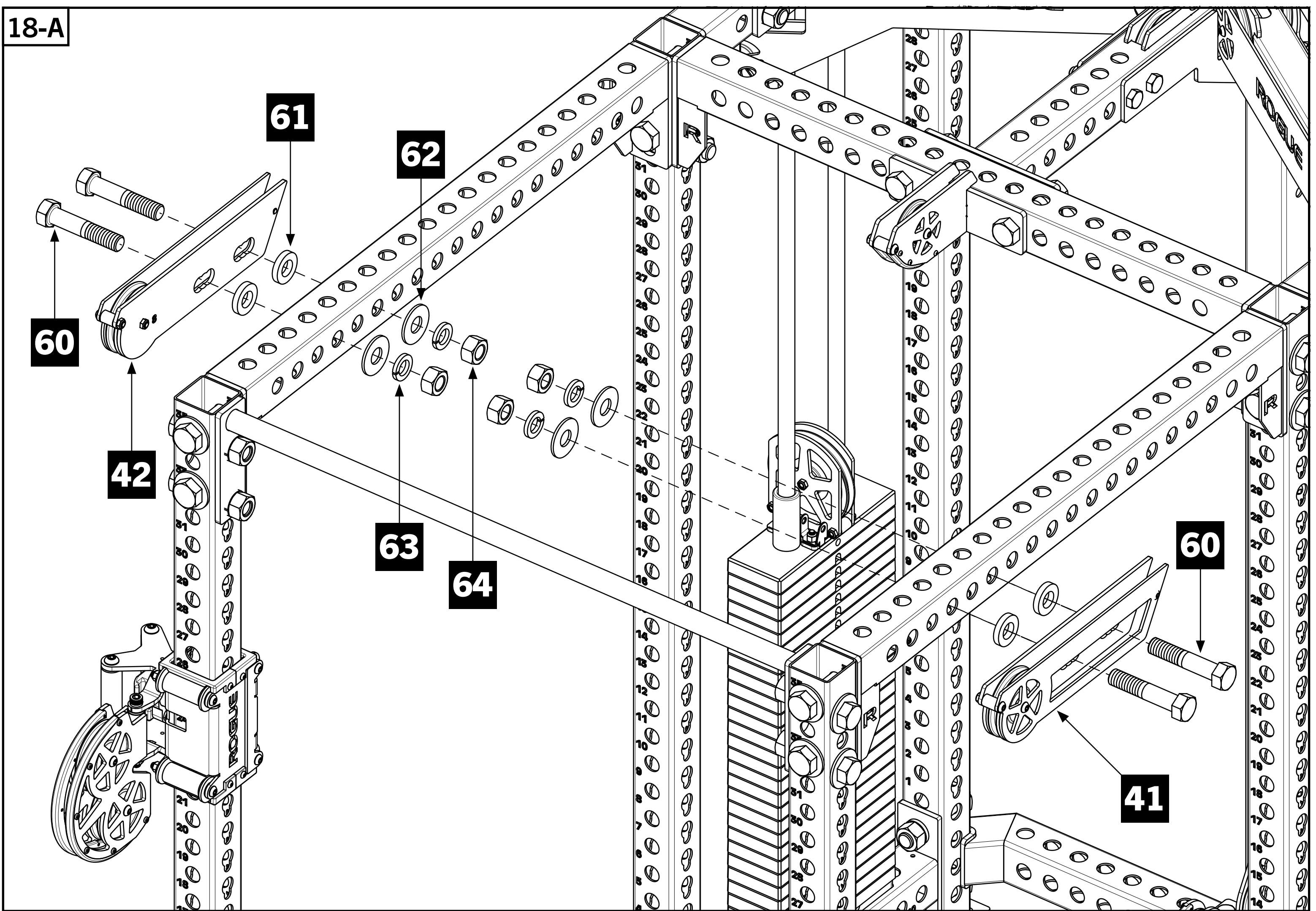
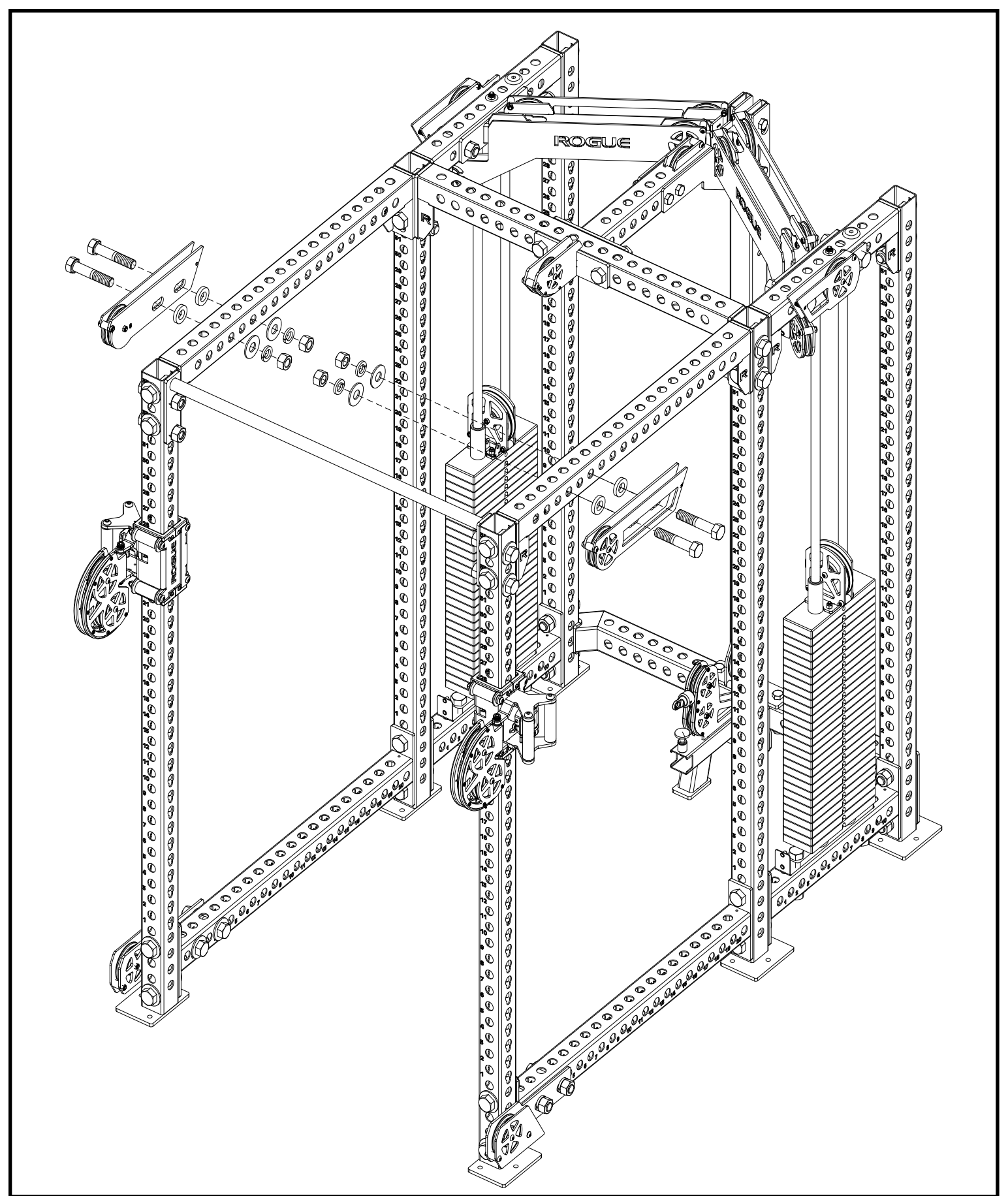

# STEP 19

- Bolt Bottom Front Side Pulley Assembly - RH [43] and -LH [44] to the Front Low Crossmembers using 1" x 5" Hex Bolts [60], 1" x 3/8" Pulley Bracket Spacers [61], 1" Flat Washers [62], 1" Lock Washers [63], and 1" Hex Nuts [64] as shown.

- **!** 43" Front Low Crossmember is shown. The Bottom Front Side Pulley Assembly holes utilized will depend on length of your Front Crossmembers. Use the diagram below to determine which holes to use.

**Note:**

- Bolt hardware through the holes between number cutouts '1' & '2' and '3' & '4' on your Front Low Crossmembers [3].
- Bolt heads should be oriented on the inside of rack as shown.

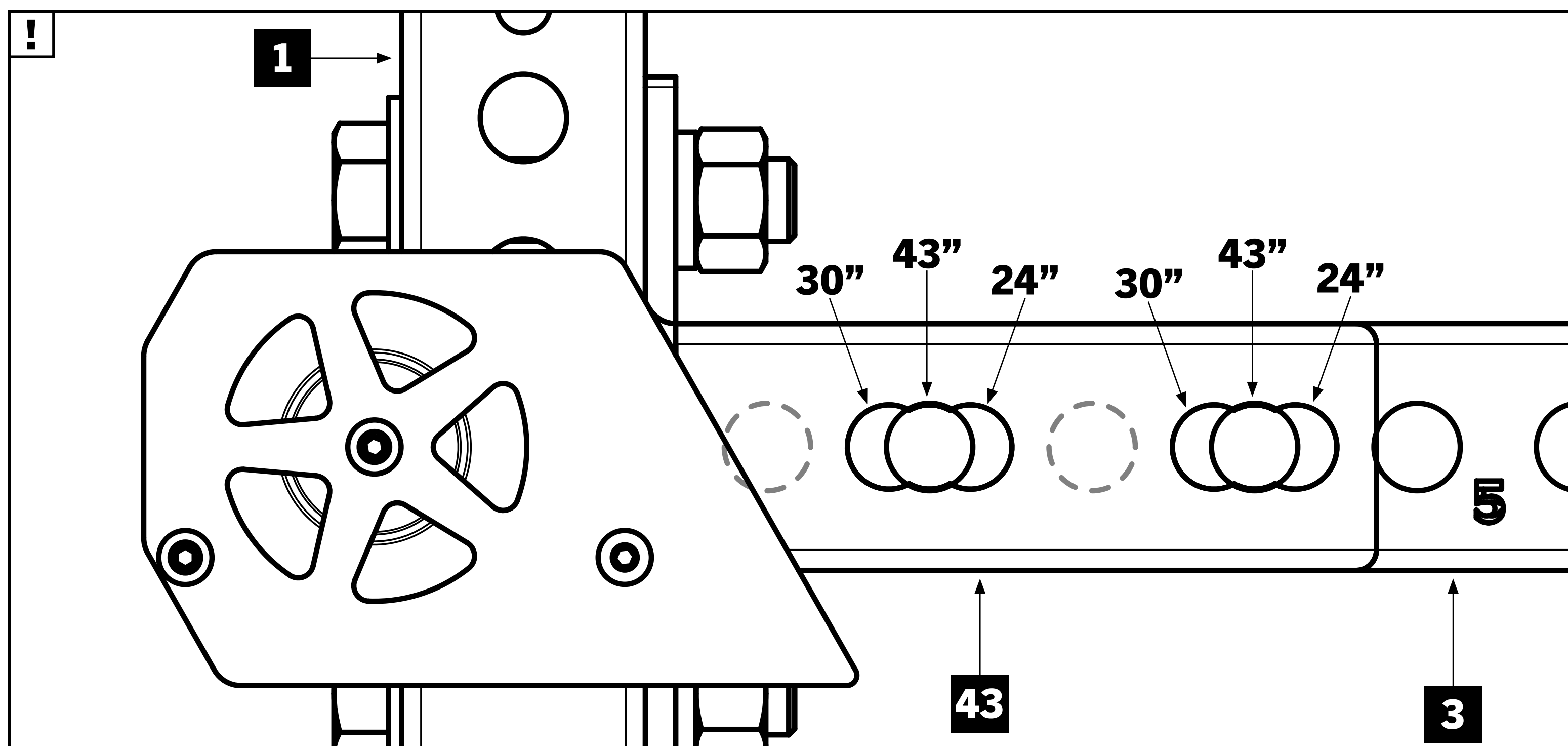
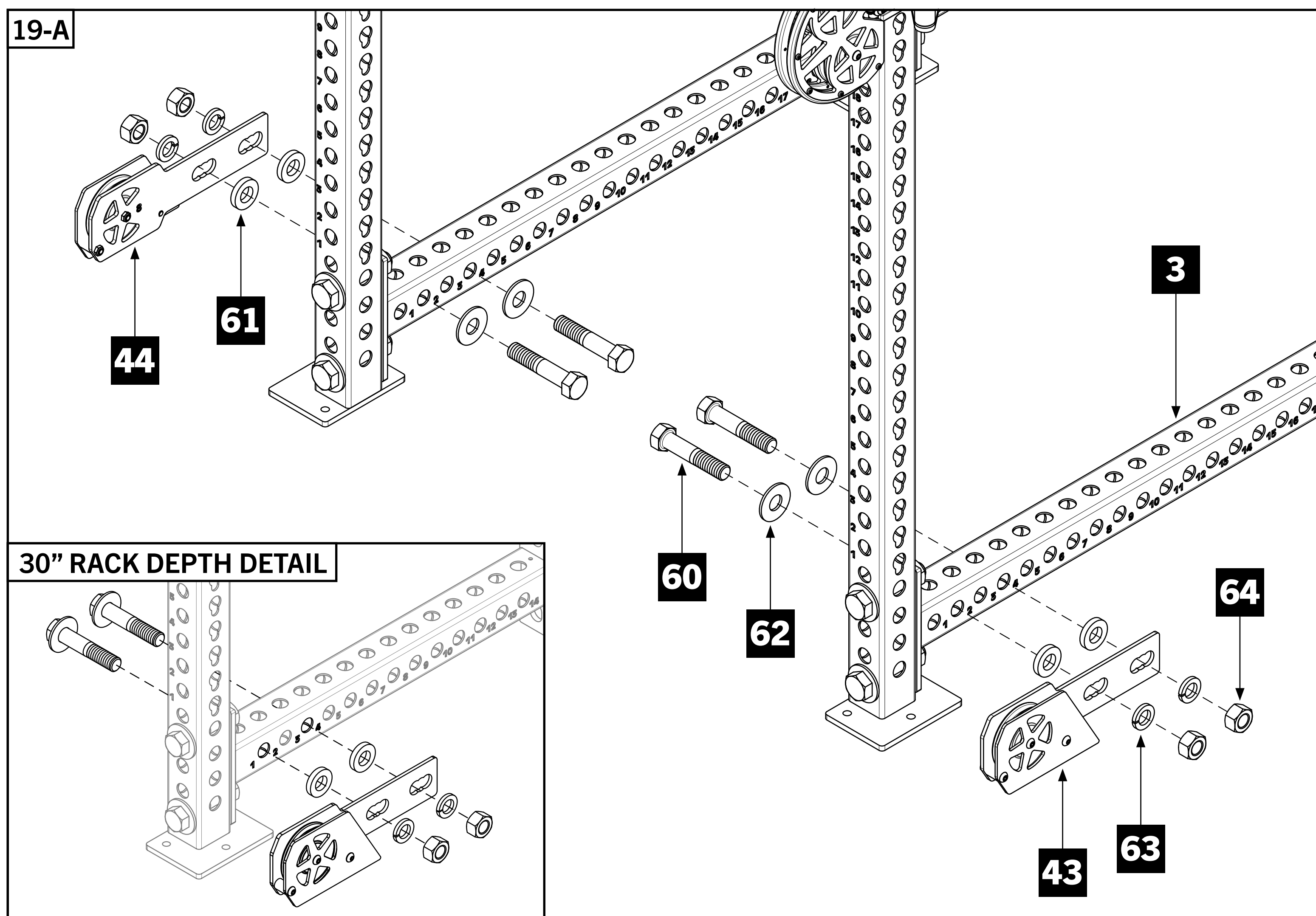
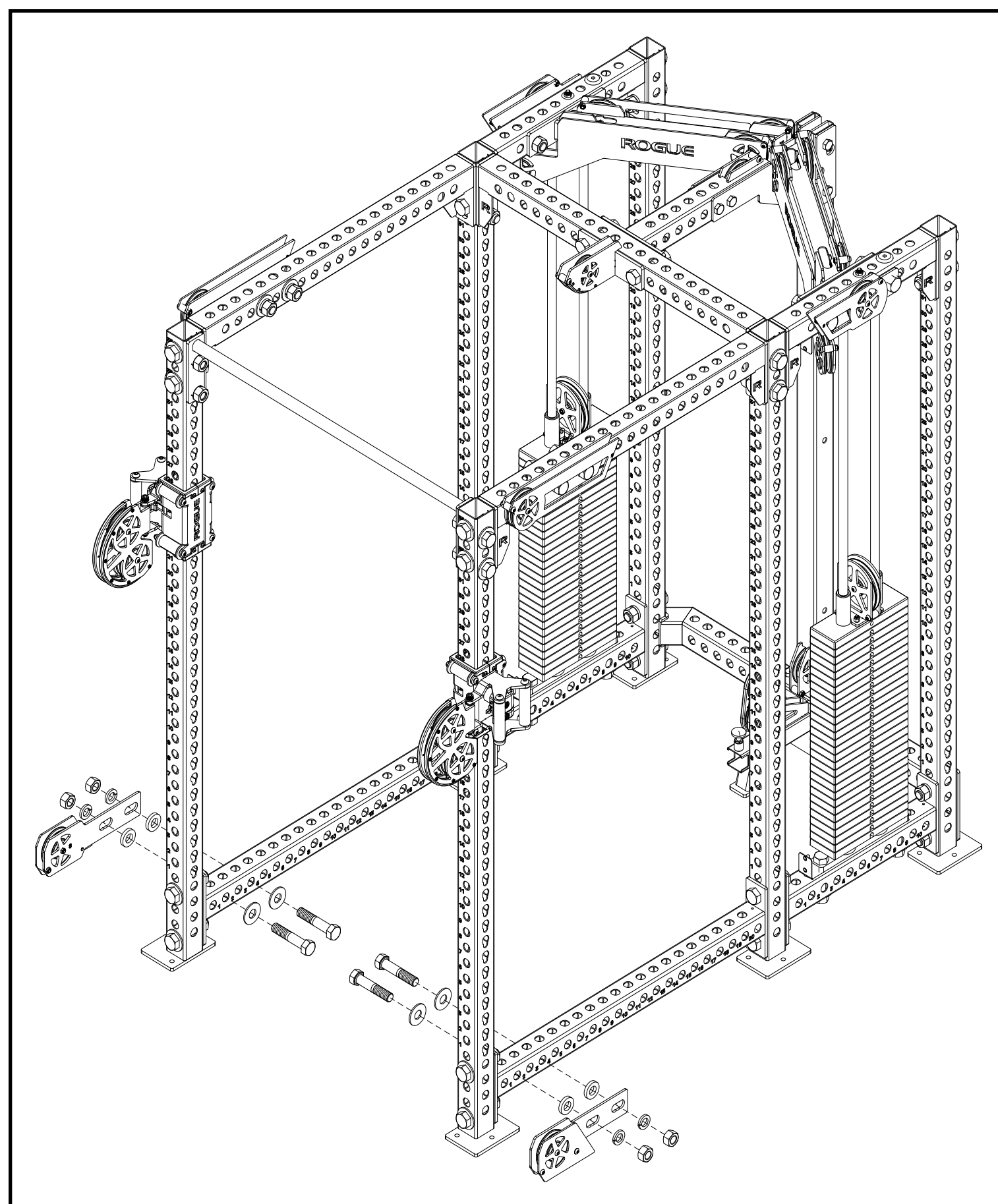

## STEP 20

- Bolt Bottom Rear Side Pulley Assembly - RH [45] and -LH [46] to the 24" Rear Low Crossmembers using 1" x 5" Hex Bolts [60], 1" x 3/8" Pulley Bracket Spacers [61], 1" Flat Washers [62], 1" Lock Washers [63], and 1" Hex Nuts [64] as shown.

### Note:

- Bolt hardware through the holes between number cutouts '3' & '4' and '5' & '6' on 24" Rear Low Crossmembers [5] with the bolt heads oriented inside of rack as shown.

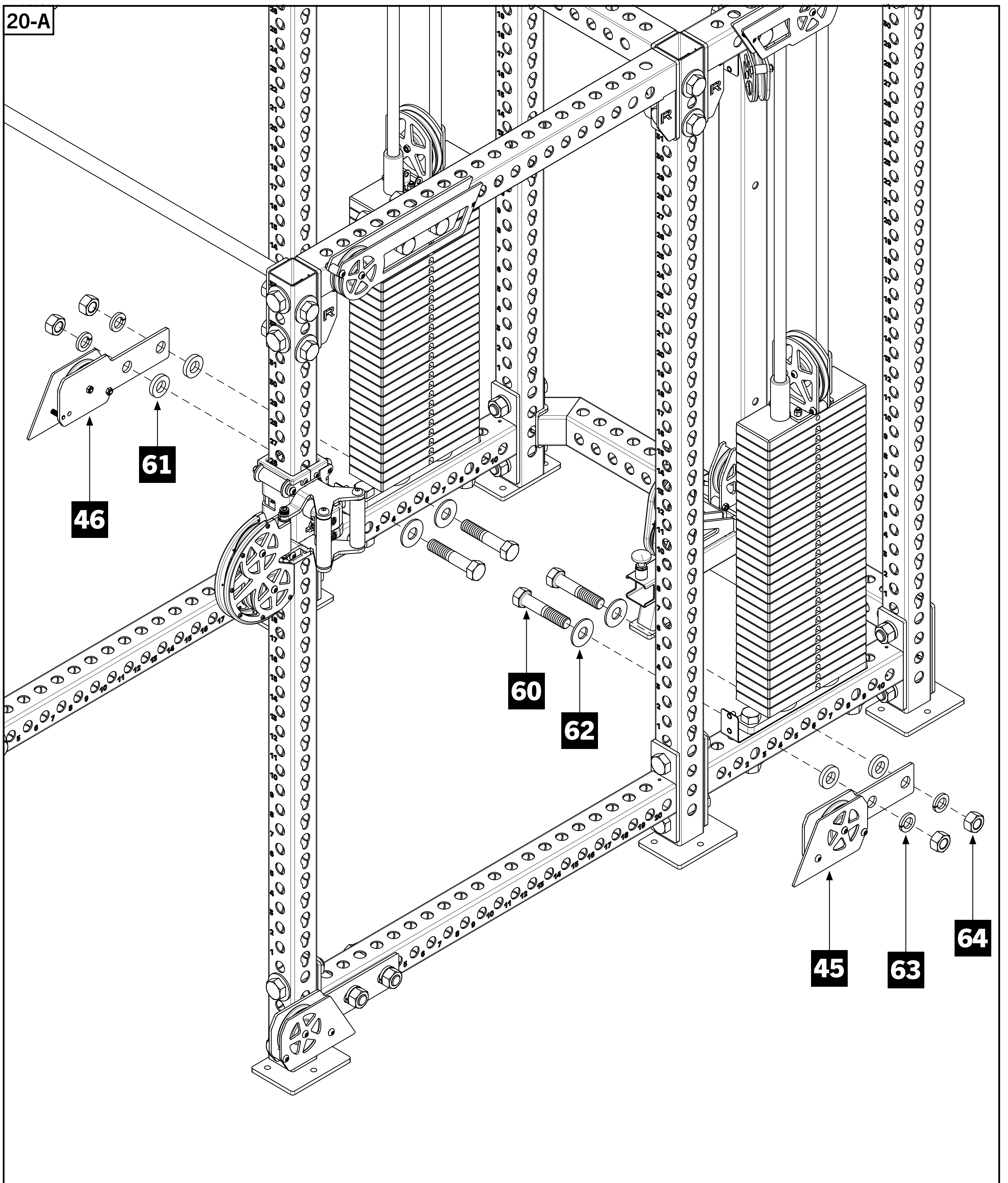
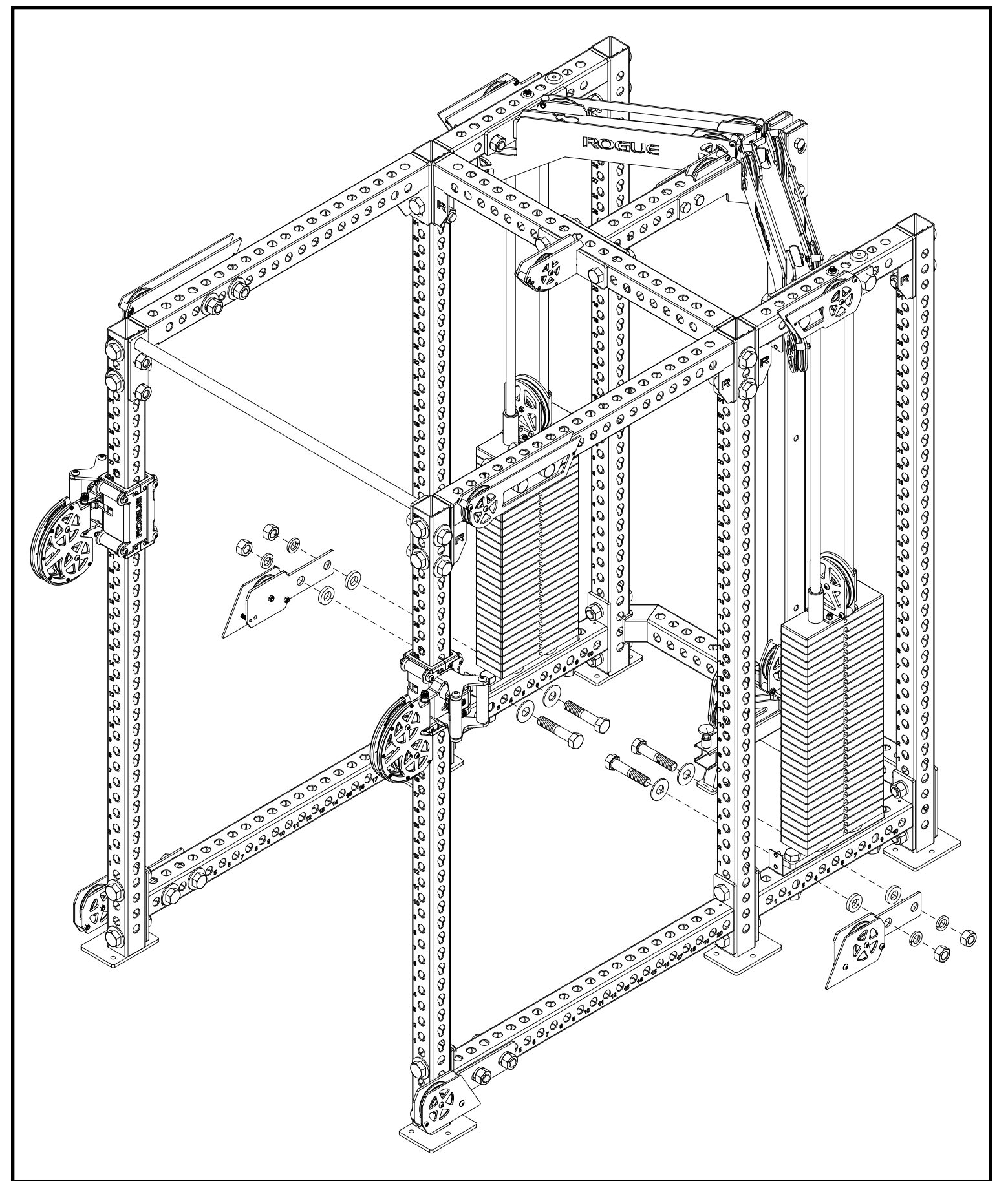

## STEP 21

- Unwind Trolley Cable (Blue Tag) [50] to remove twists/kinks.
- Starting on the Right Side of the rack, screw bolt ends of Trolley Cables [50] into stop block on back of RH Trolleys [19].
- Loosen the hex nut if needed to ensure approximately 1/2" of threads are showing between the bolt head and nut.
- Feed cable up to the Top Front Side Pulley Assembly - RH, feeding around the pulley shown in **21-B** and then immediately towards the back of the rack.
- Feed cable up to the Top Rear Side Pulley Assembly - RH, feeding around the pulley shown in **21-C** and then immediately towards the bottom of the rack.

- Continuing down towards the Weight Stack, feed cable around the large 6" Pulley located on top of the Weight Stack Stem. **Tip:** a flathead screwdriver may be used to help guide cable through turn 16.

### Note:

- Arrow directions and numbers on parts shown in **21-D** do not correspond to numbering sequence. (Will be represented by 16 and 17).

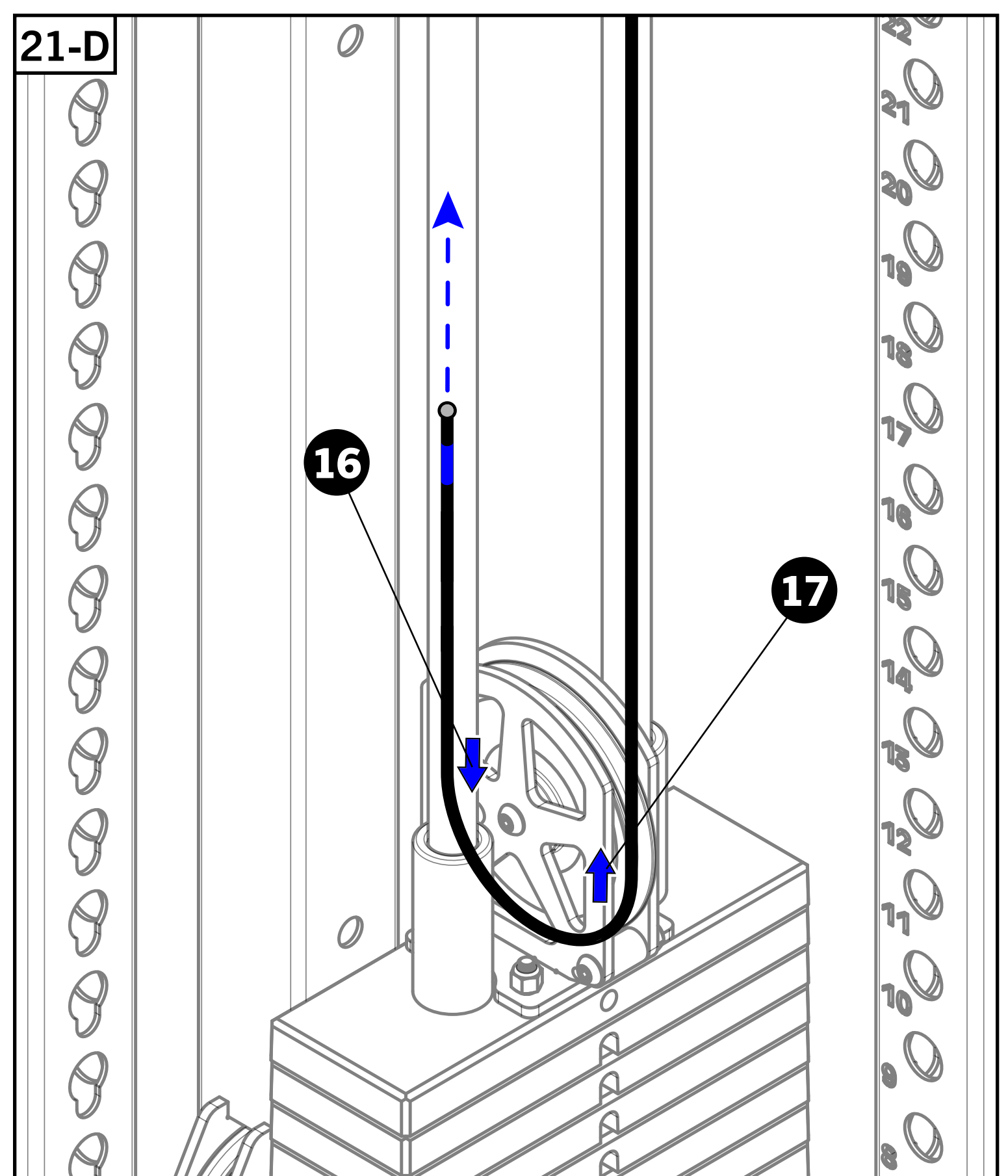
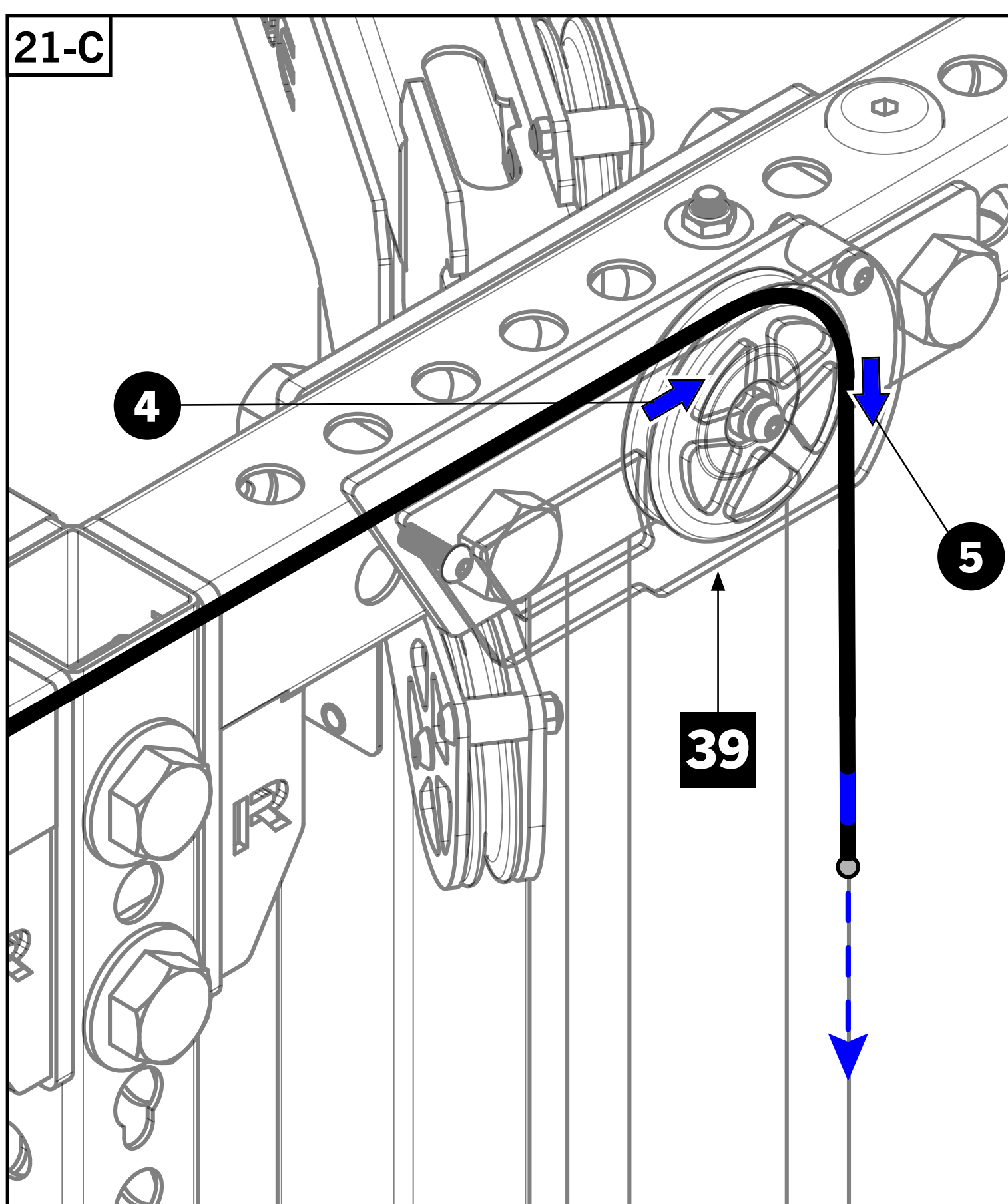
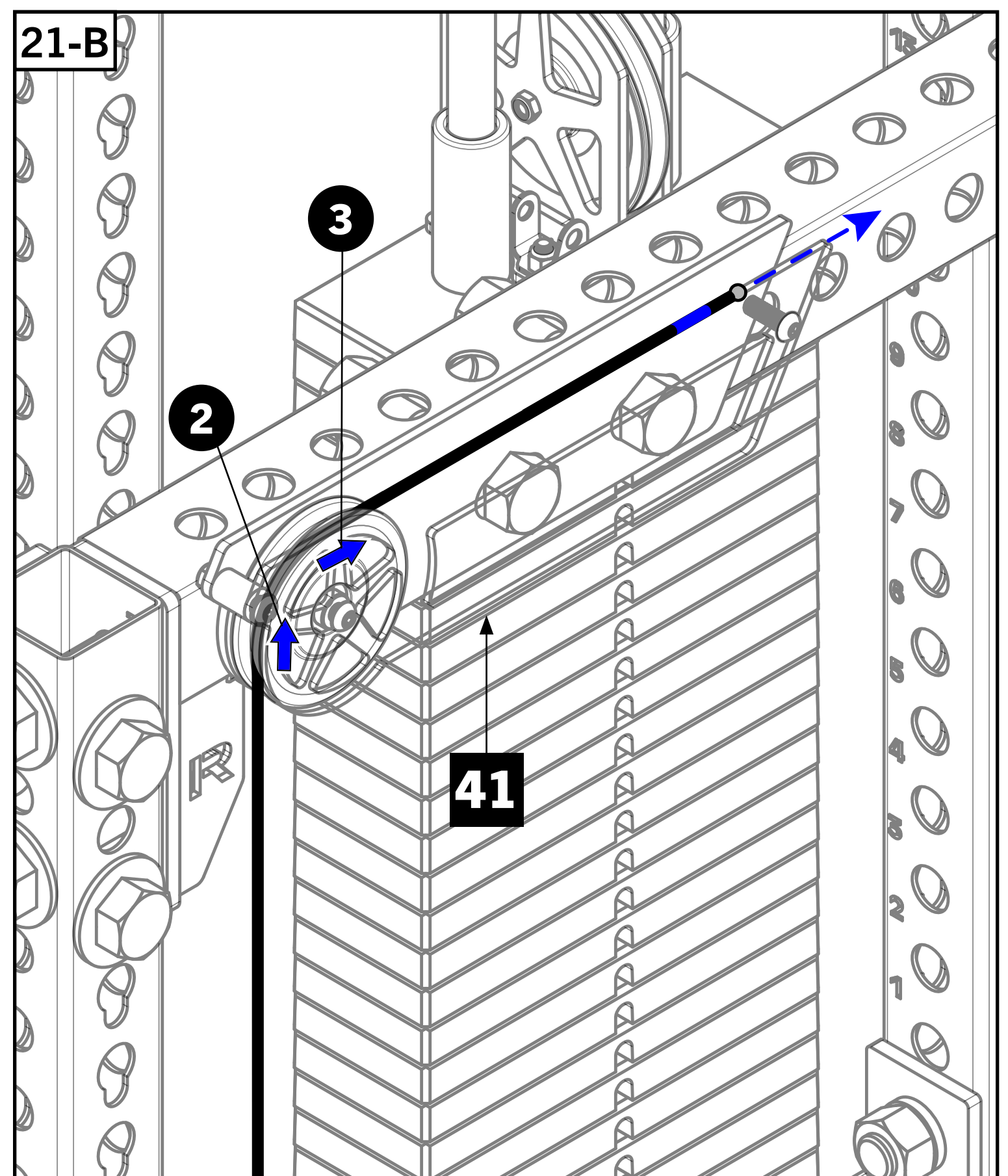
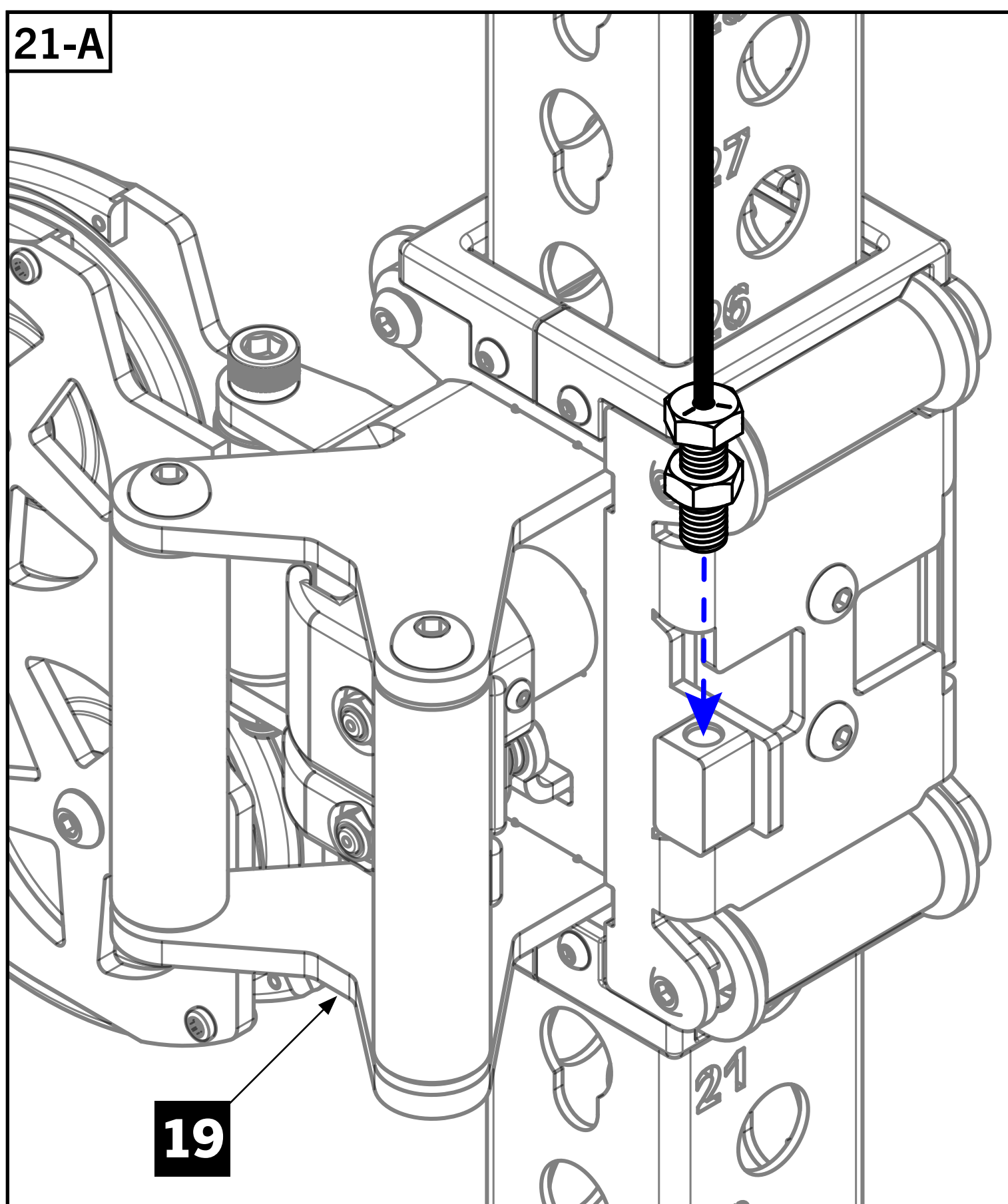

## STEP 22

- Continue feeding around the first pulley on Top Rear Angle Crossmember - RH following the arrow indicator (6,7) directions towards the back of the rack.
- Feed cable around the next angled pulley at the back of the Top Rear Angle Cross member - RH and downward.
- Hold the Peanut Pulley [47] in the air, ensuring the arrow stickers correspond to diagram **22-B**.
- Feed the cable down and around the upper pulley of Peanut Pulley and then back up towards the Top Rear Angle Crossmember - RH [22].

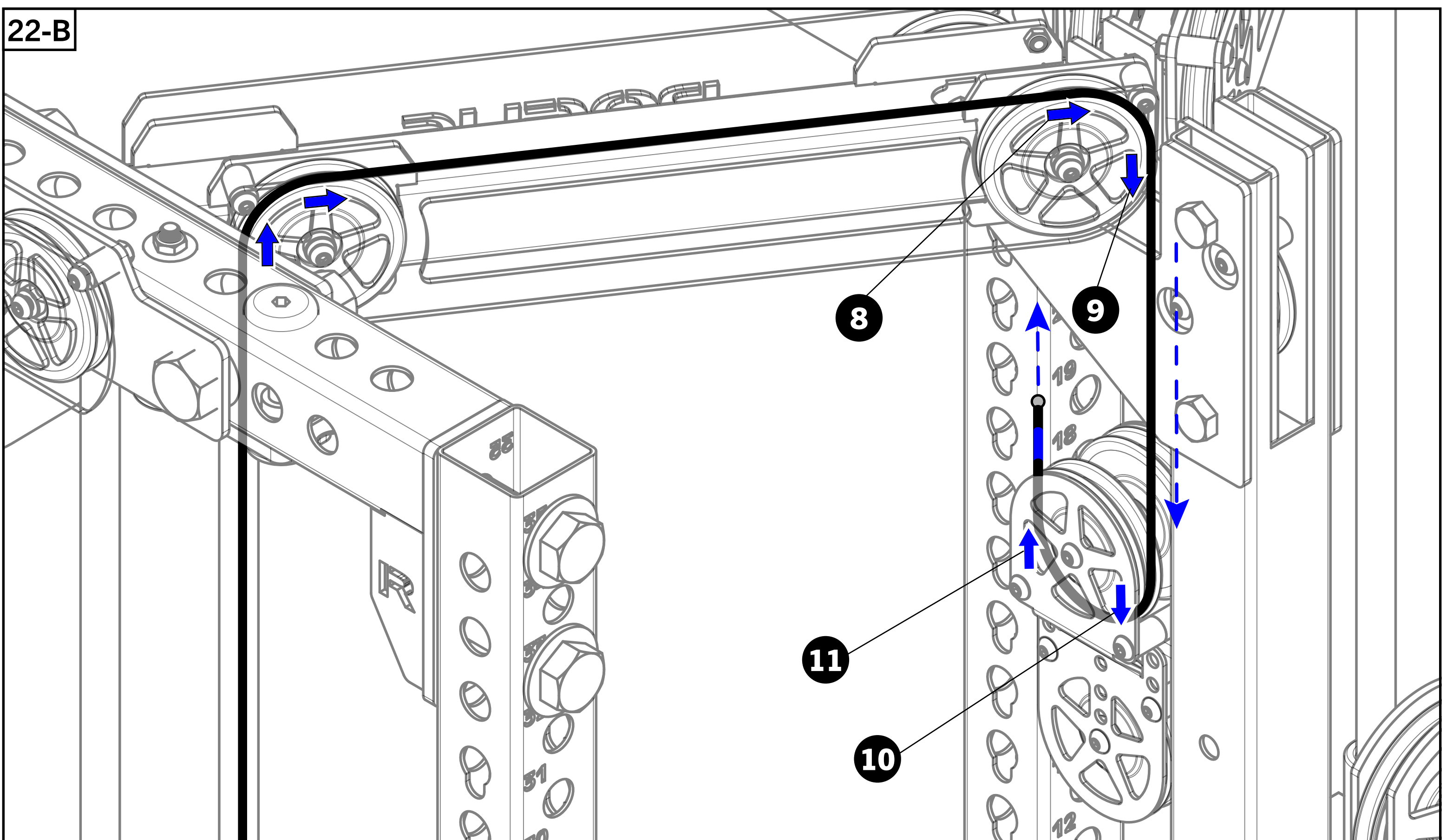
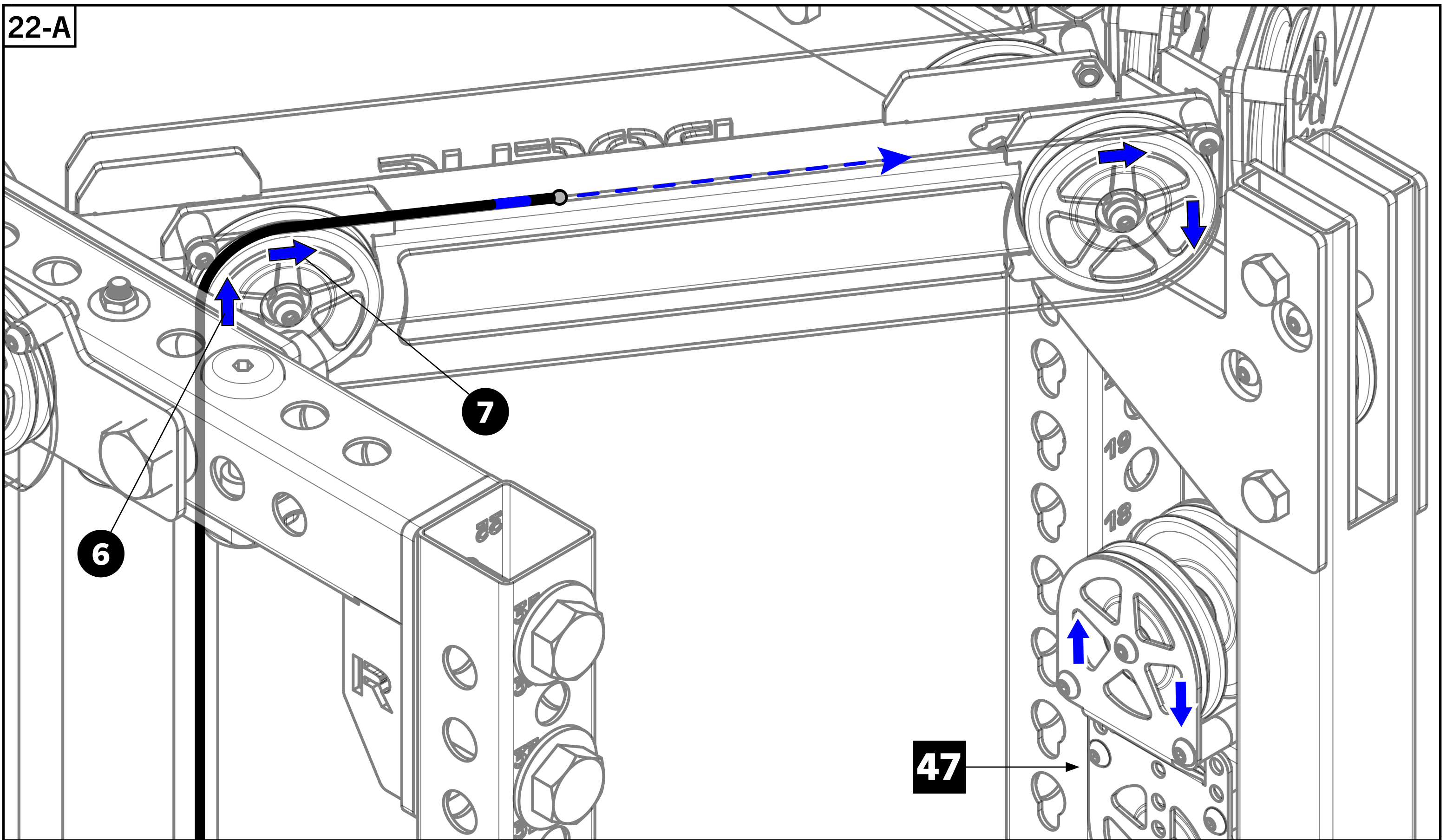
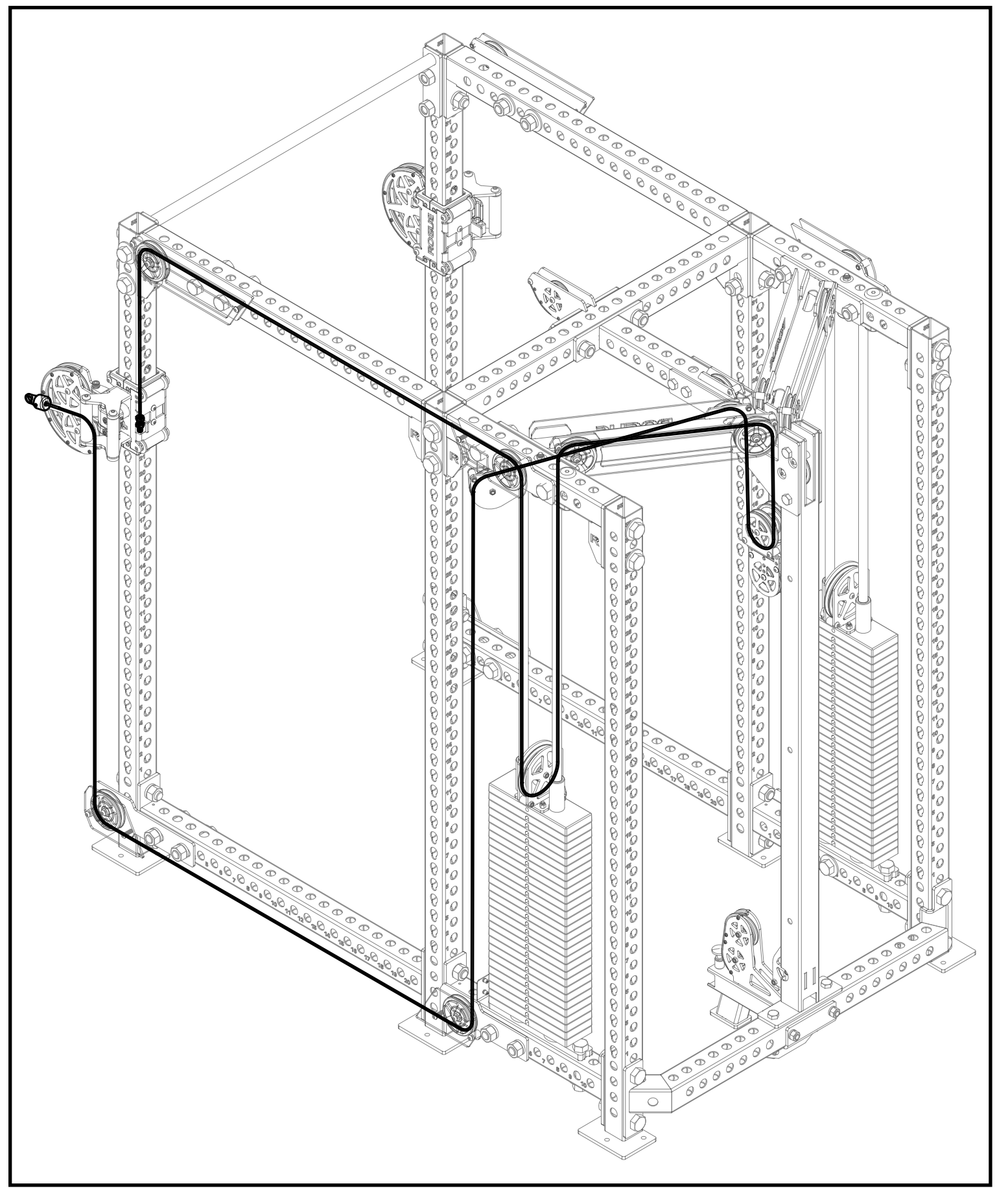

## STEP 23

- From the Peanut Pulley, continue to feed the cable up and around the rear pulley in the Top Rear Angle Crossmember - RH [22] following arrows 12 and 13.
- Continue towards the outside of the rack and feed cable around the angled pulley shown in 23-B and down towards the Bottom Rear Side Pulley Assembly - RH [45].

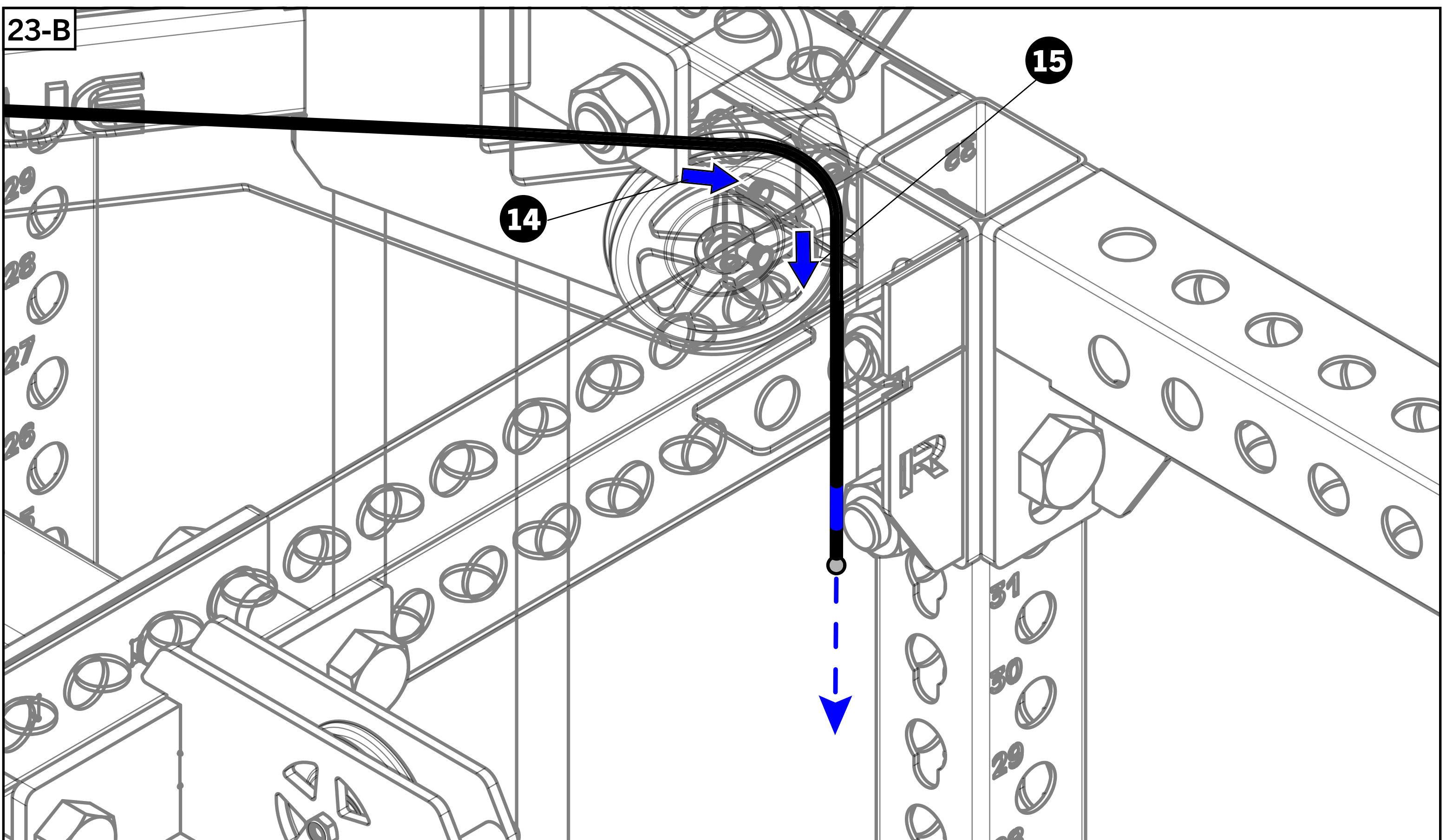
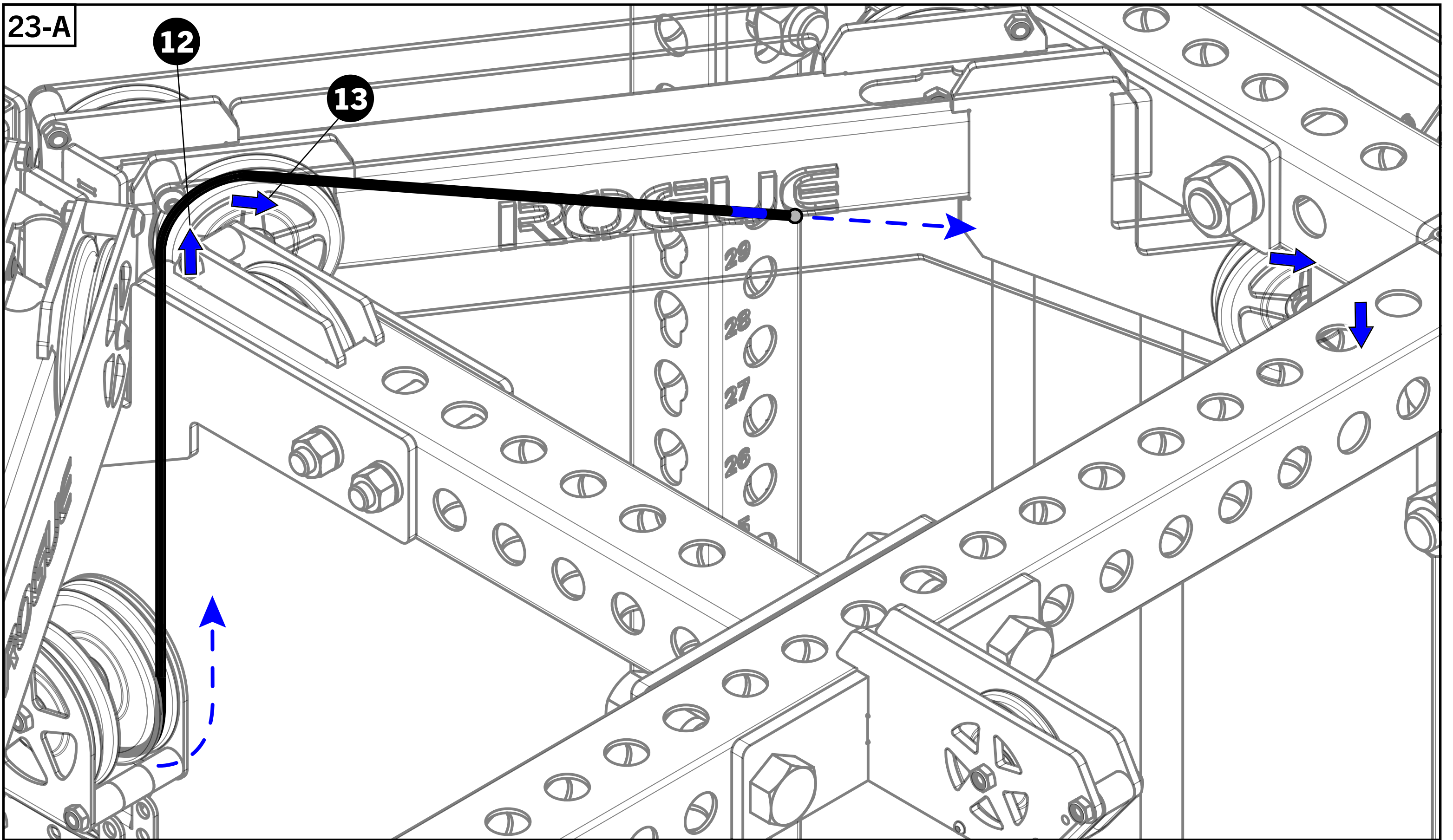
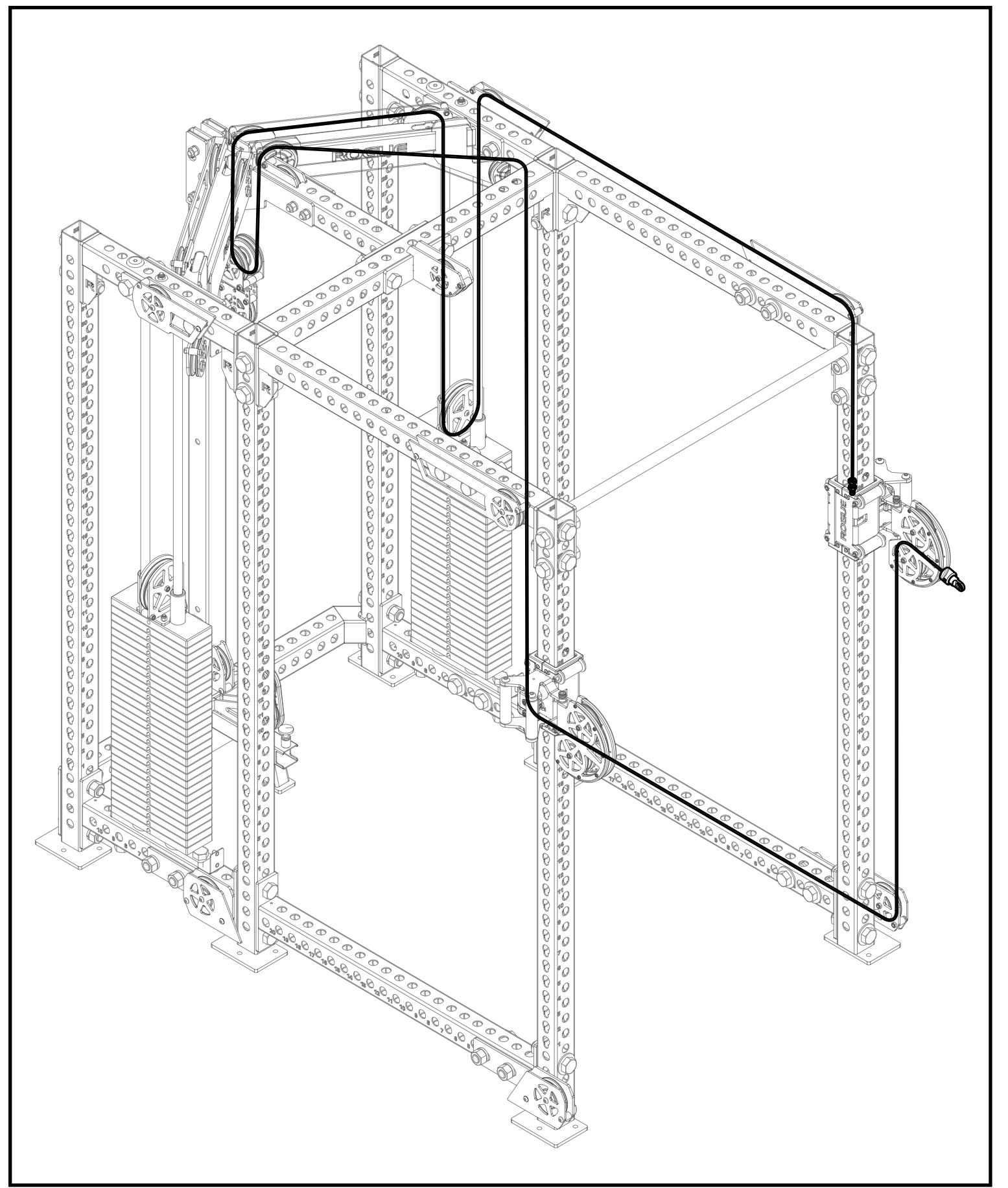

## STEP 24

- Note: Skip from arrow 15 to arrow 18 and continue on.
- Feed the Ball End of Trolley Cable [50] around the pulley on Bottom Rear Pulley Assembly (arrows 18 & 19) and continue towards the front of rack.
- Continue around the Bottom Front Side Pulley Assembly - RH and then up and out through the Swivel Trolley - RH [19].

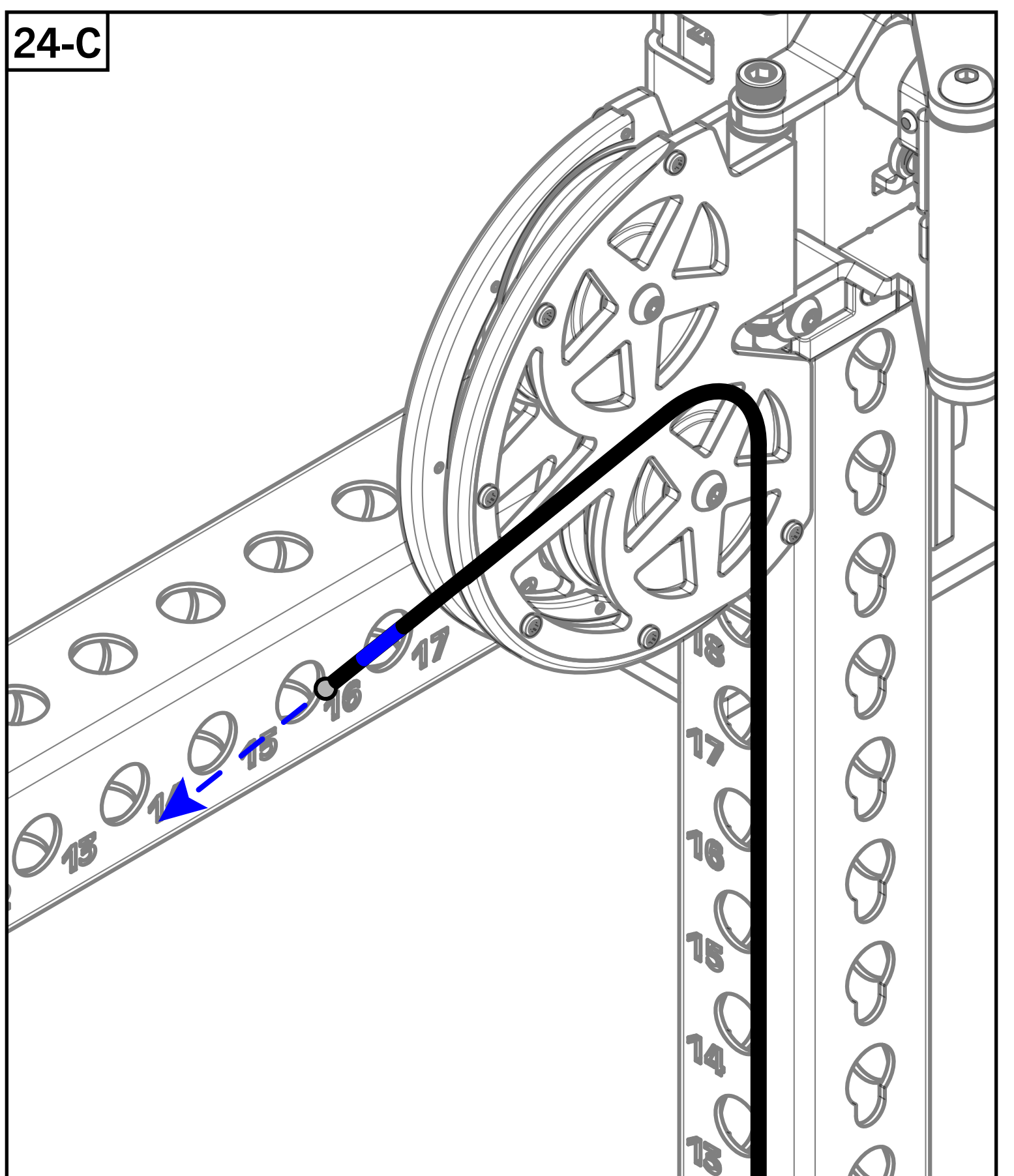
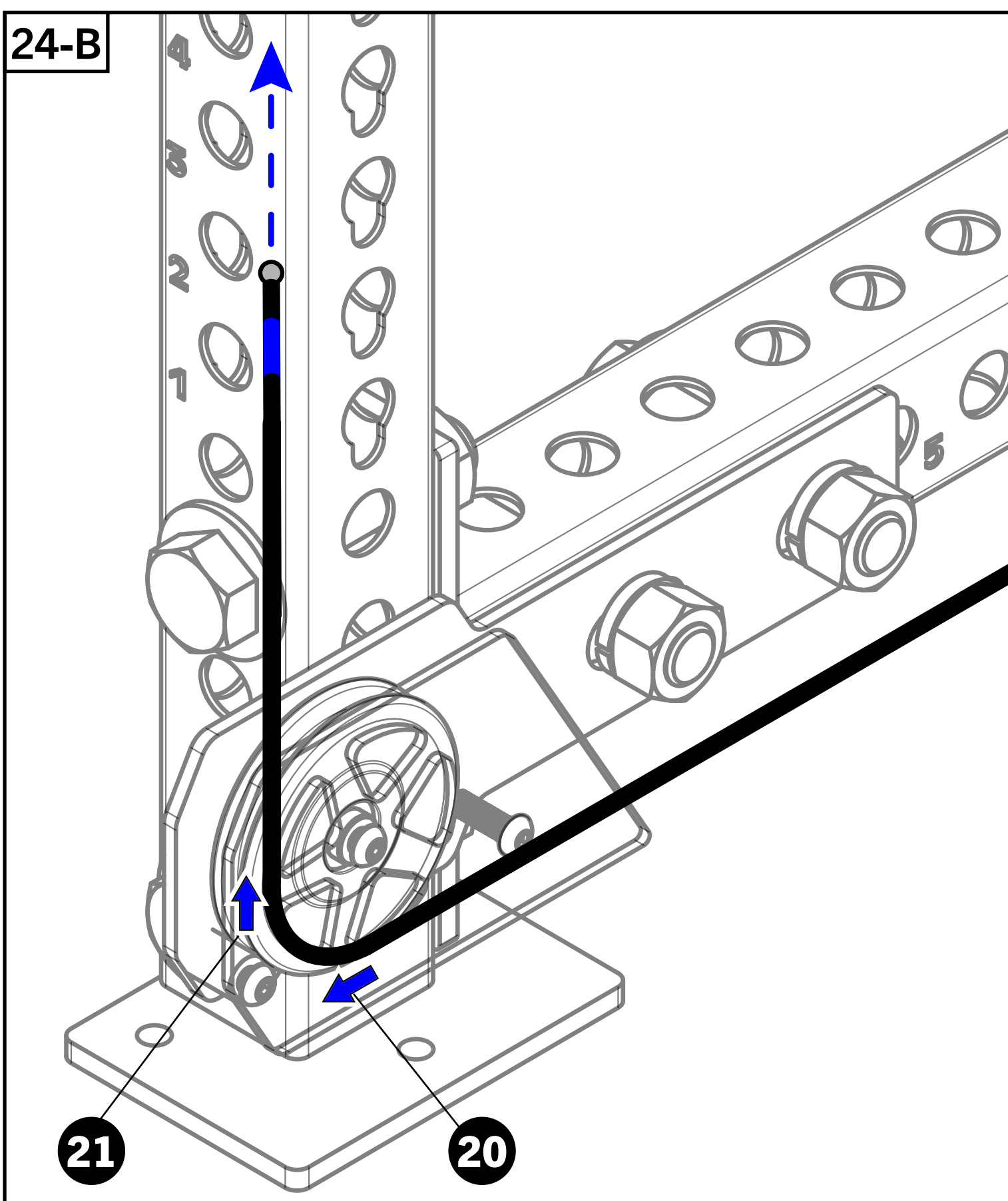
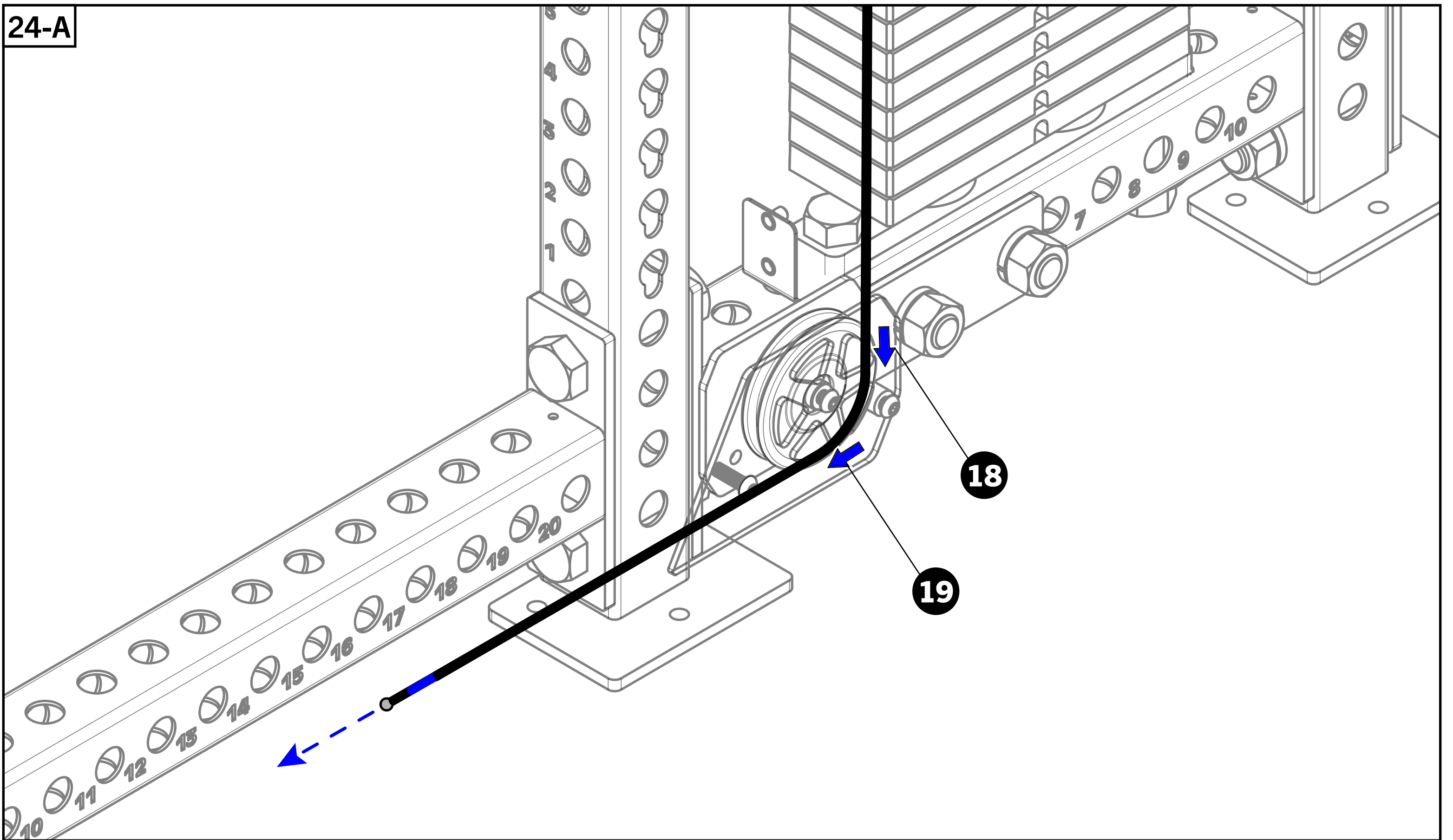
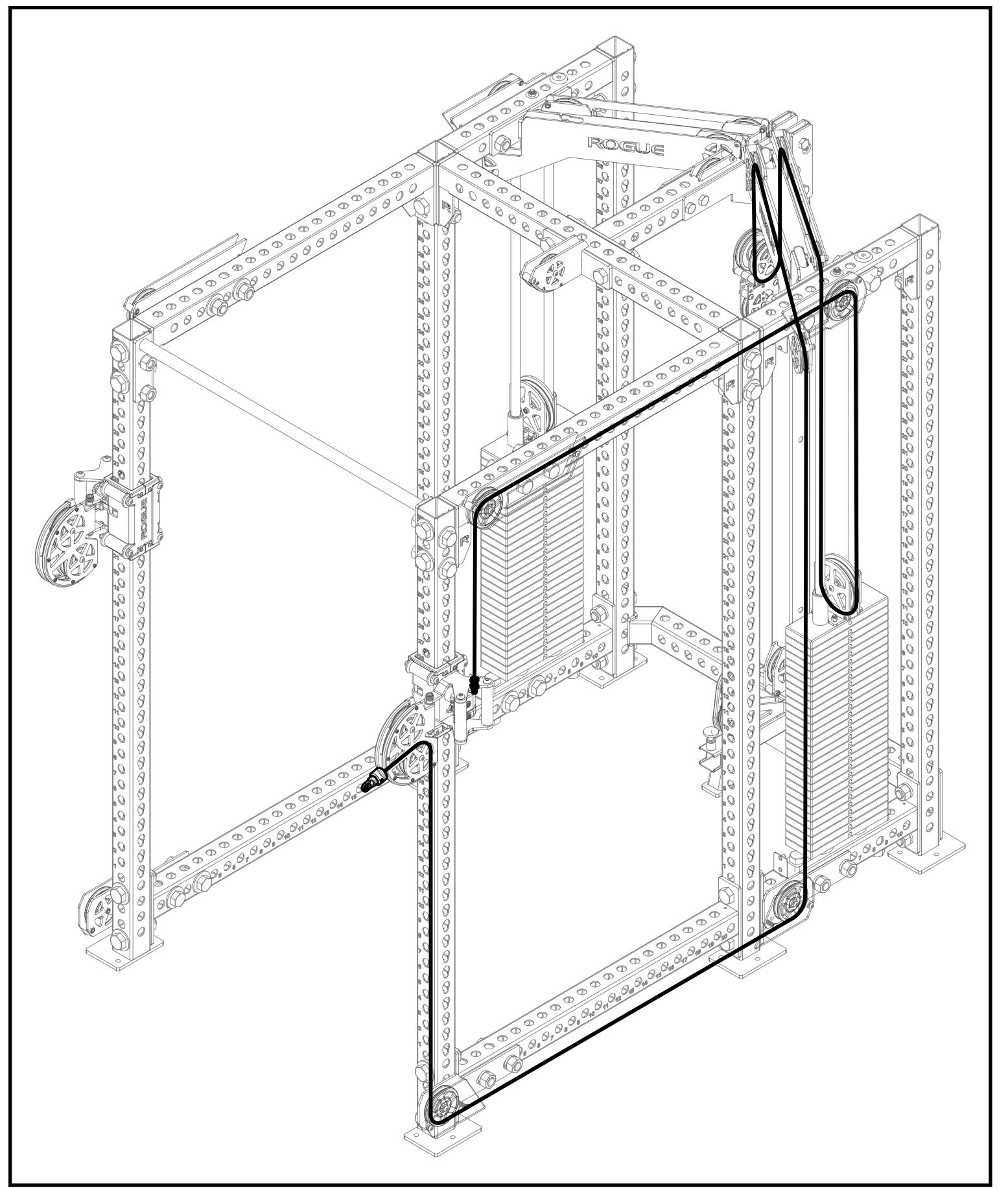

# STEP 25

## Tools Required:

- 3/32" Allen Key & 5/8" Wrench
- Completely disassemble the loose Clevis included with cable by unscrewing set screws and Split Threaded Insert, and remove blue tag on end of cable.
- Slide parts over the ball on cable as shown on 25-B.

- Insert Grommet into non-threaded side of Split Threaded Insert and screw Clevis End on threaded side using 5/8" Wrench.
- Slide Plastic Stop forward and align outer holes with threaded holes on Clevis End and re-insert Set Screws. Fully tighten Set Screws.

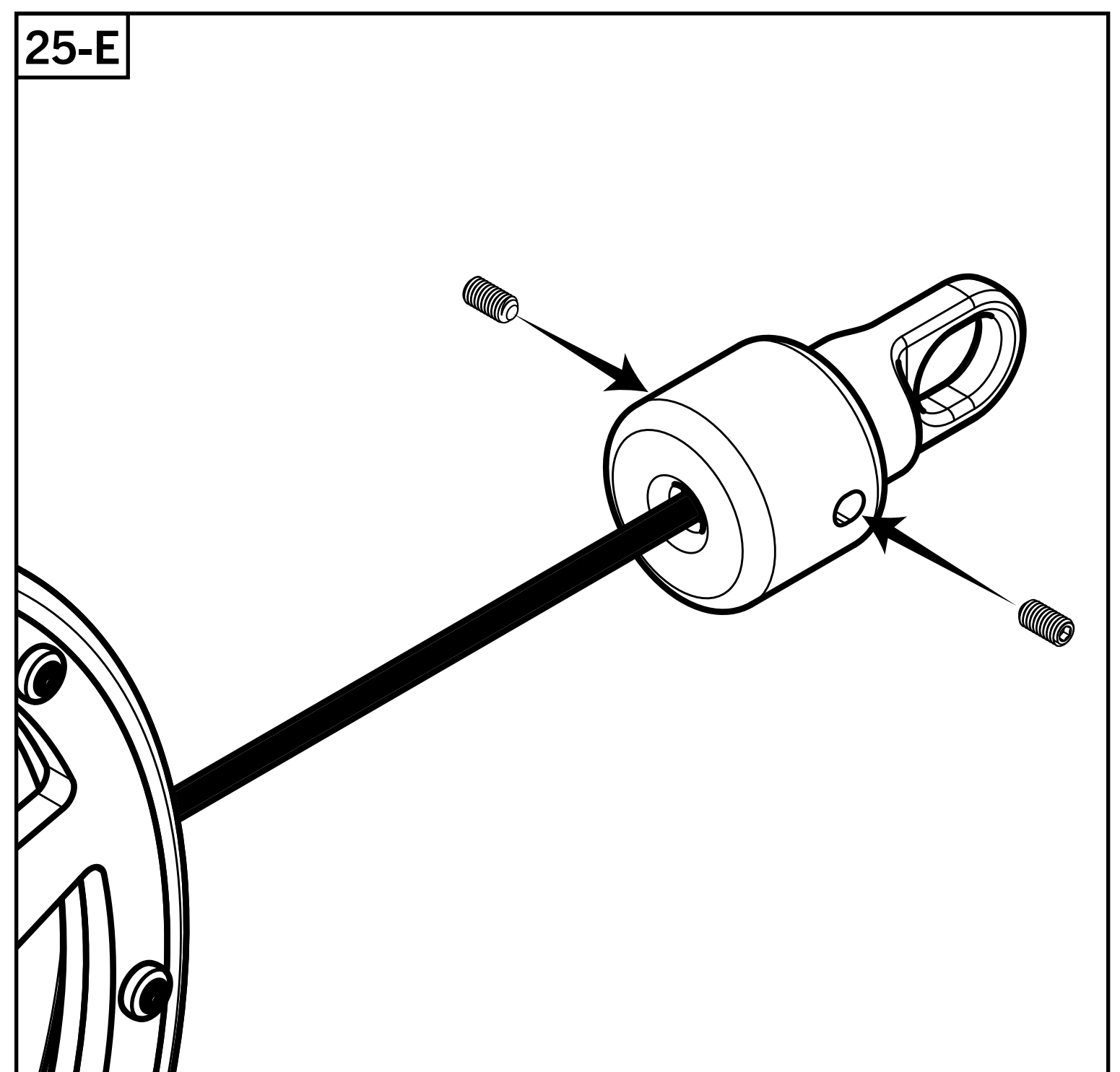
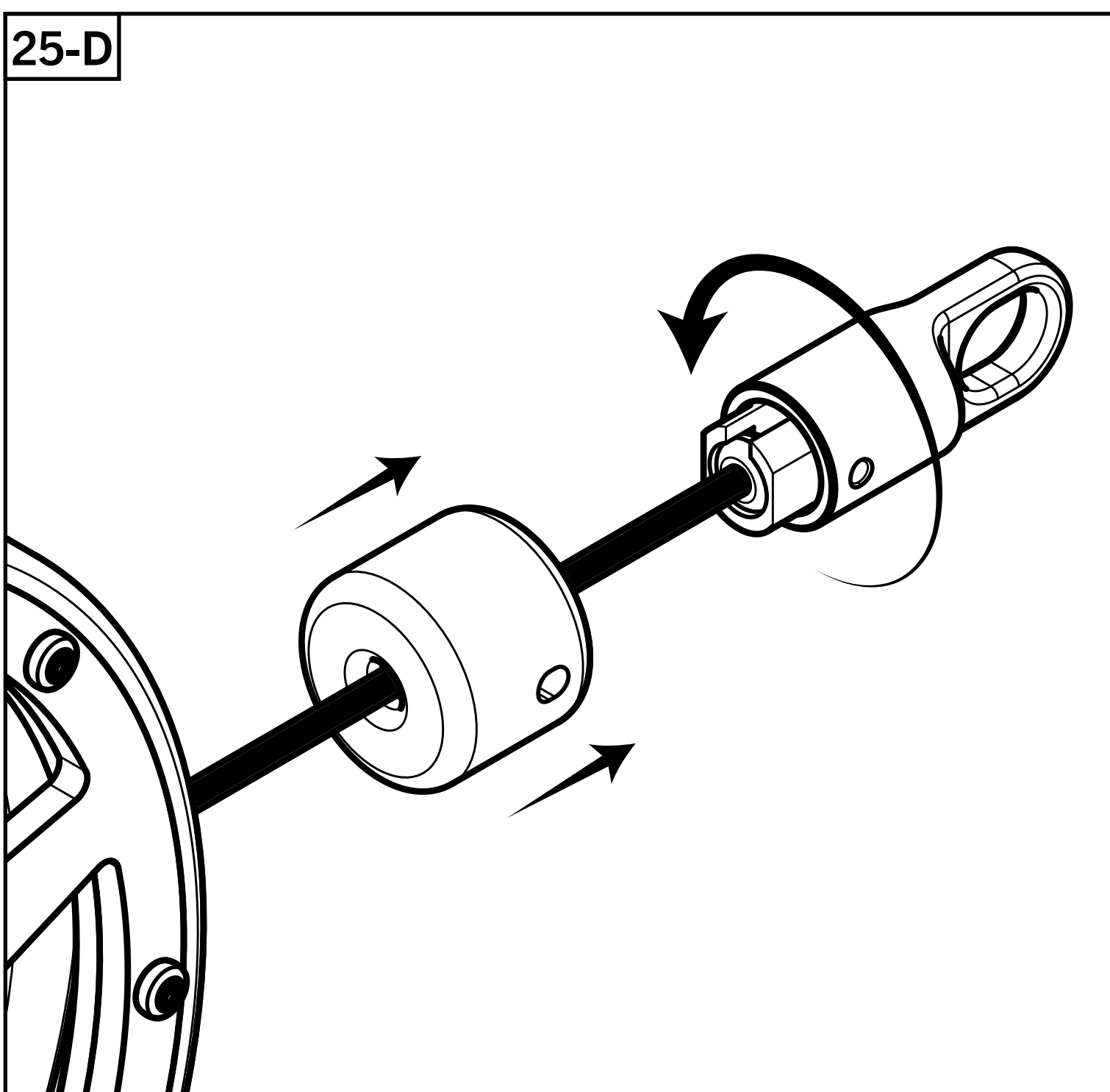
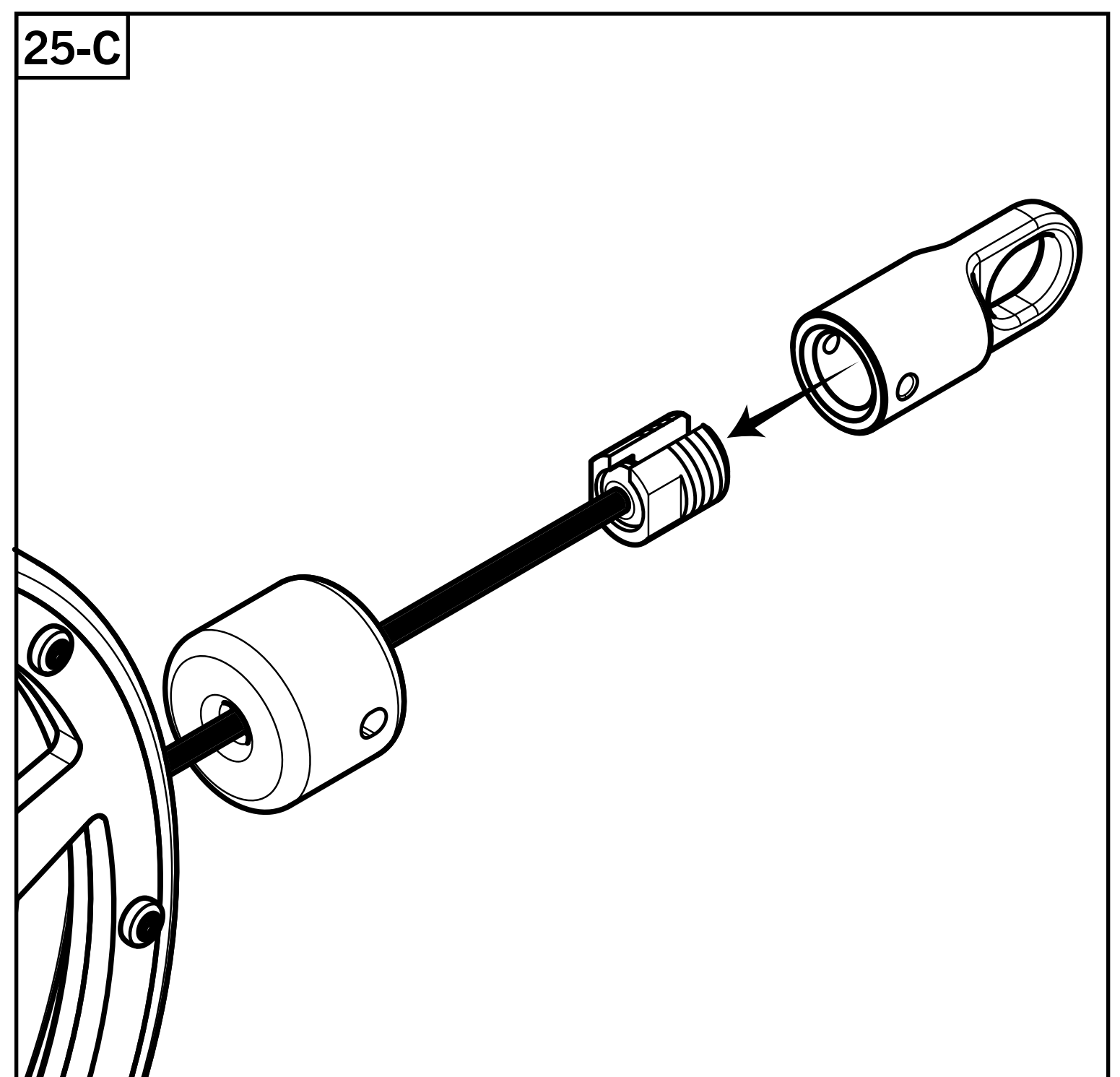
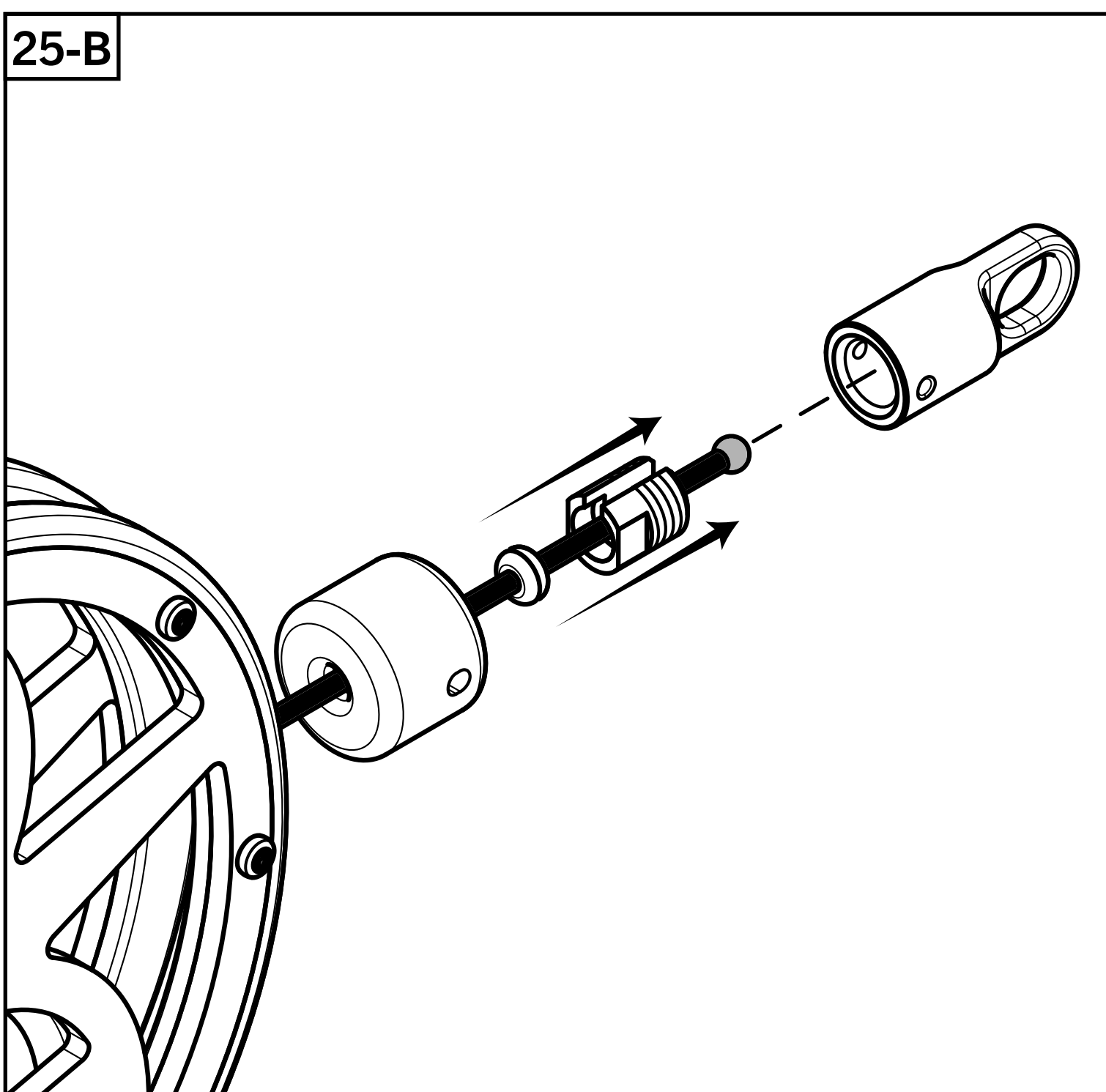
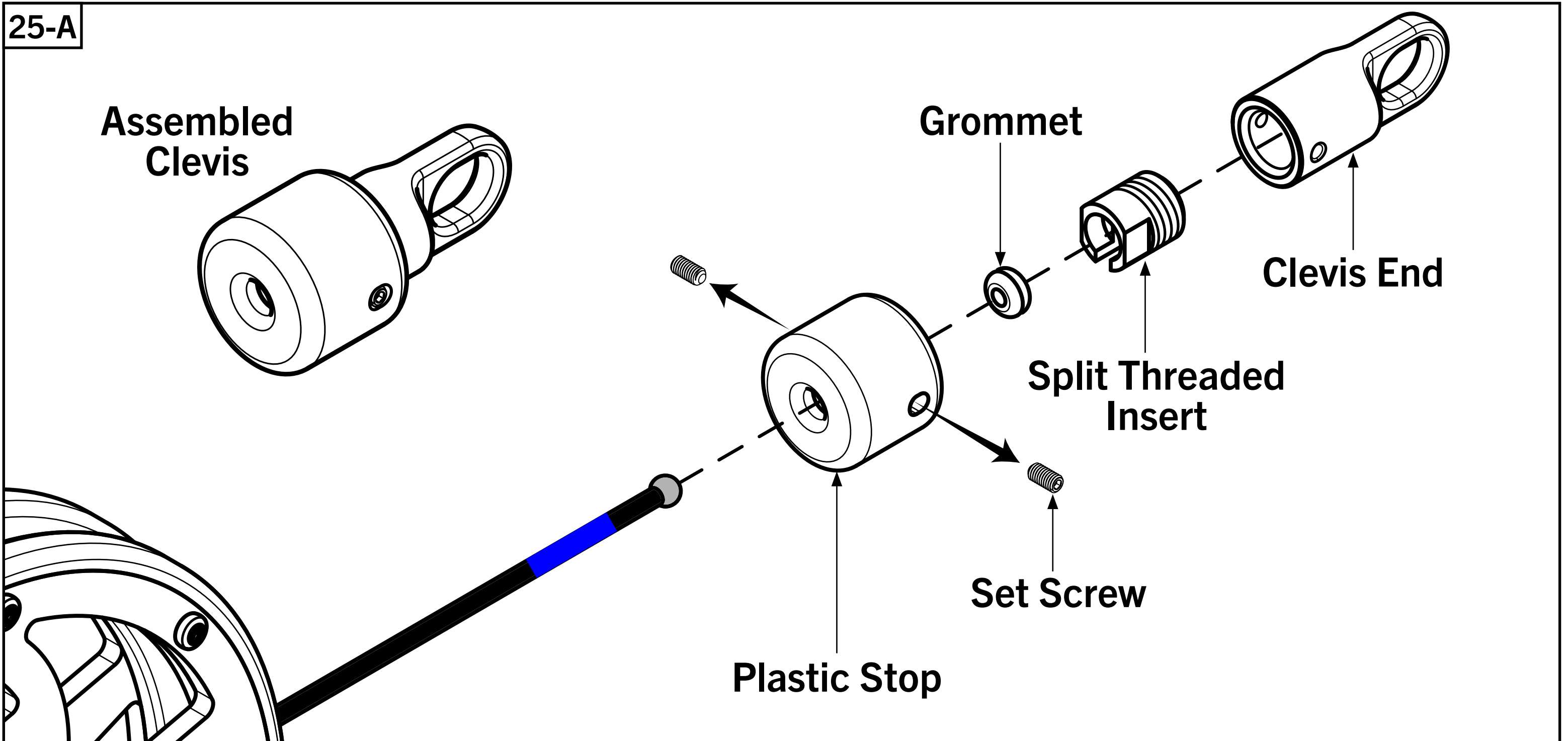

## STEP 26

### Tools Required:

- 3/32" Allen Key, and 5/8" Wrench
- Follow **STEPS 21–25** again to assemble the remaining Trolley Cable (blue tag) on the **Left Hand side of rack.**

26-A

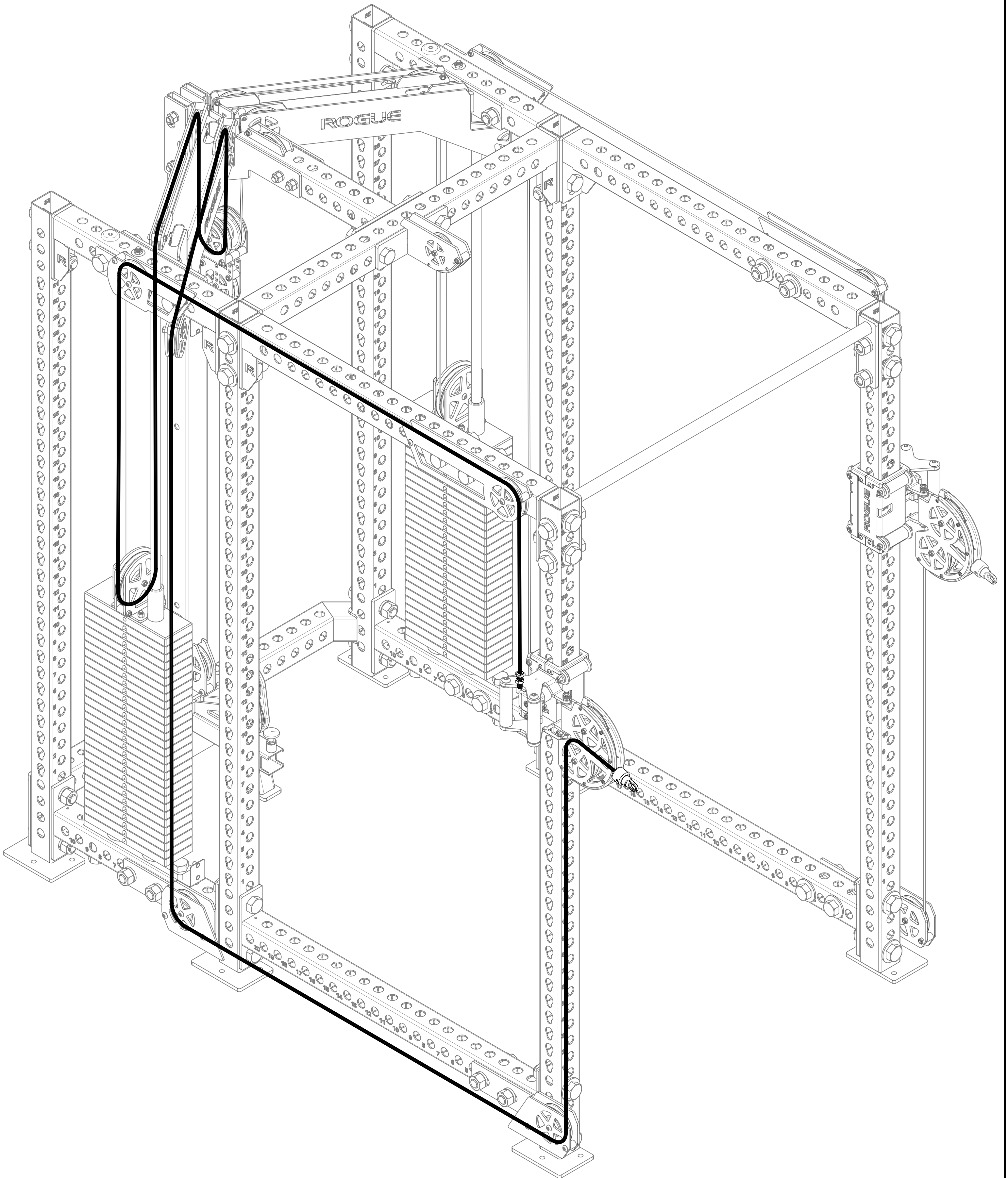

# STEP 27

## Note:

- Completely unwind and straighten out Lat Pull Cable [51] to remove any twists/kinks prior to installation.
- Next assemble the Lat Pull/Low Row cable indicated by the yellow indicator on Ball End of cable and corresponding yellow arrows shown in **STEPS 27–28**.
- Feed the Ball End of Lat Pull Cable [51] up and over the pulley in Lat Pulldown Pulley Bracket [25] and then towards the back of the rack.
- Feed around the pulley in the top of Rear 3X3 Upright [17] and then all the way down, ensuring cable runs **INSIDE THE UPRIGHT**.
- **!** Ensure cable sits in groove of pulley and runs beneath the spacer as shown.

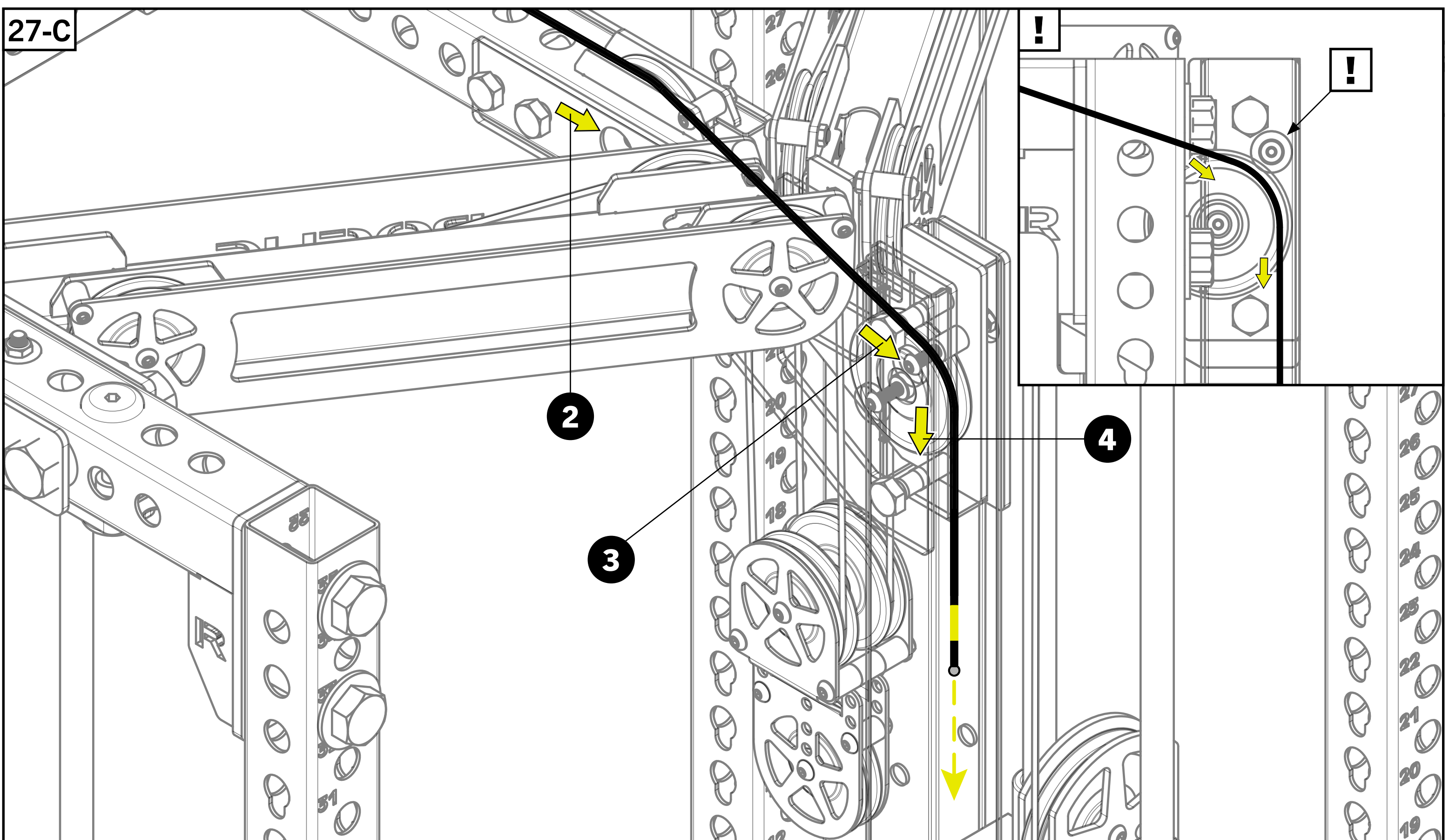
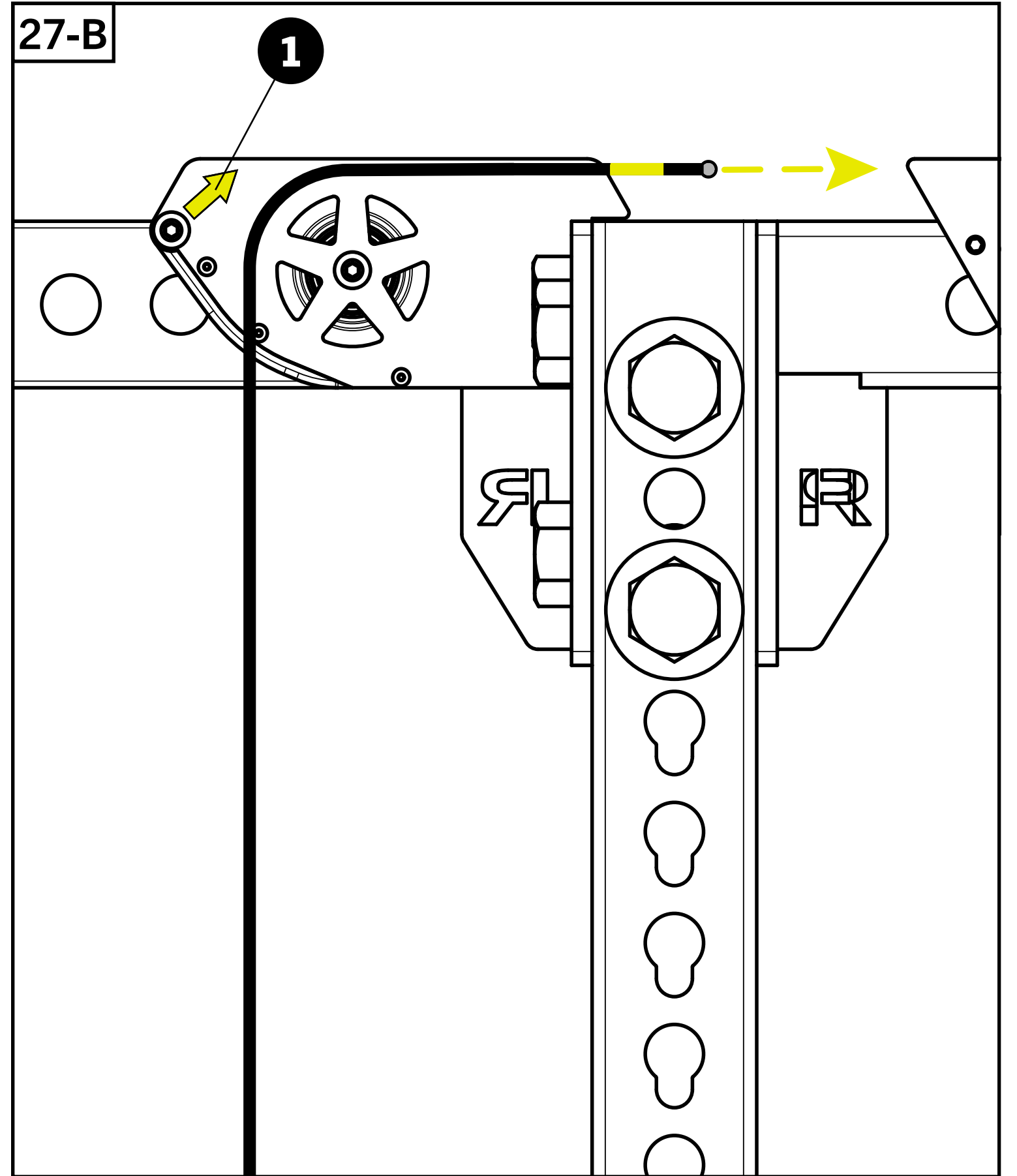
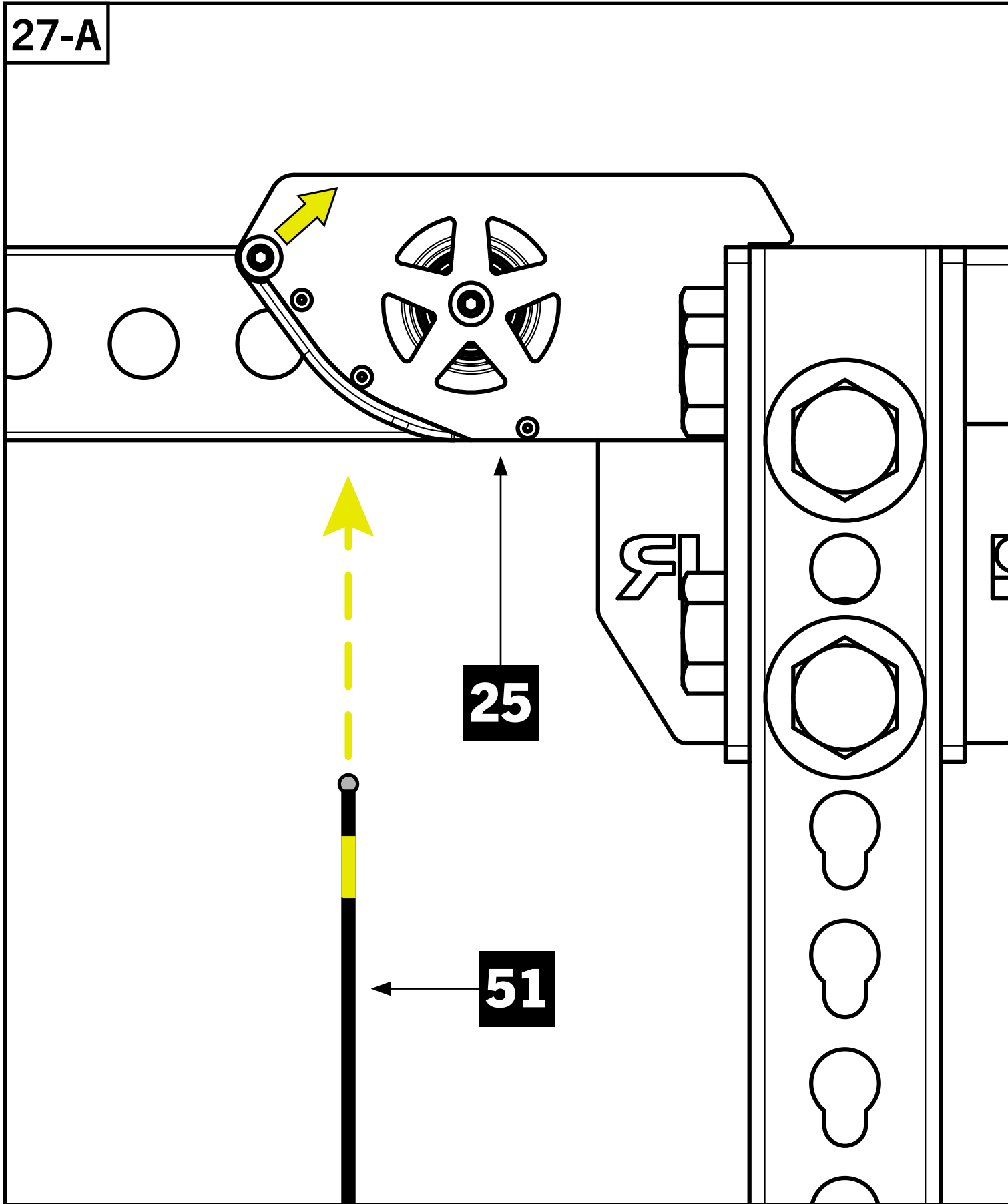
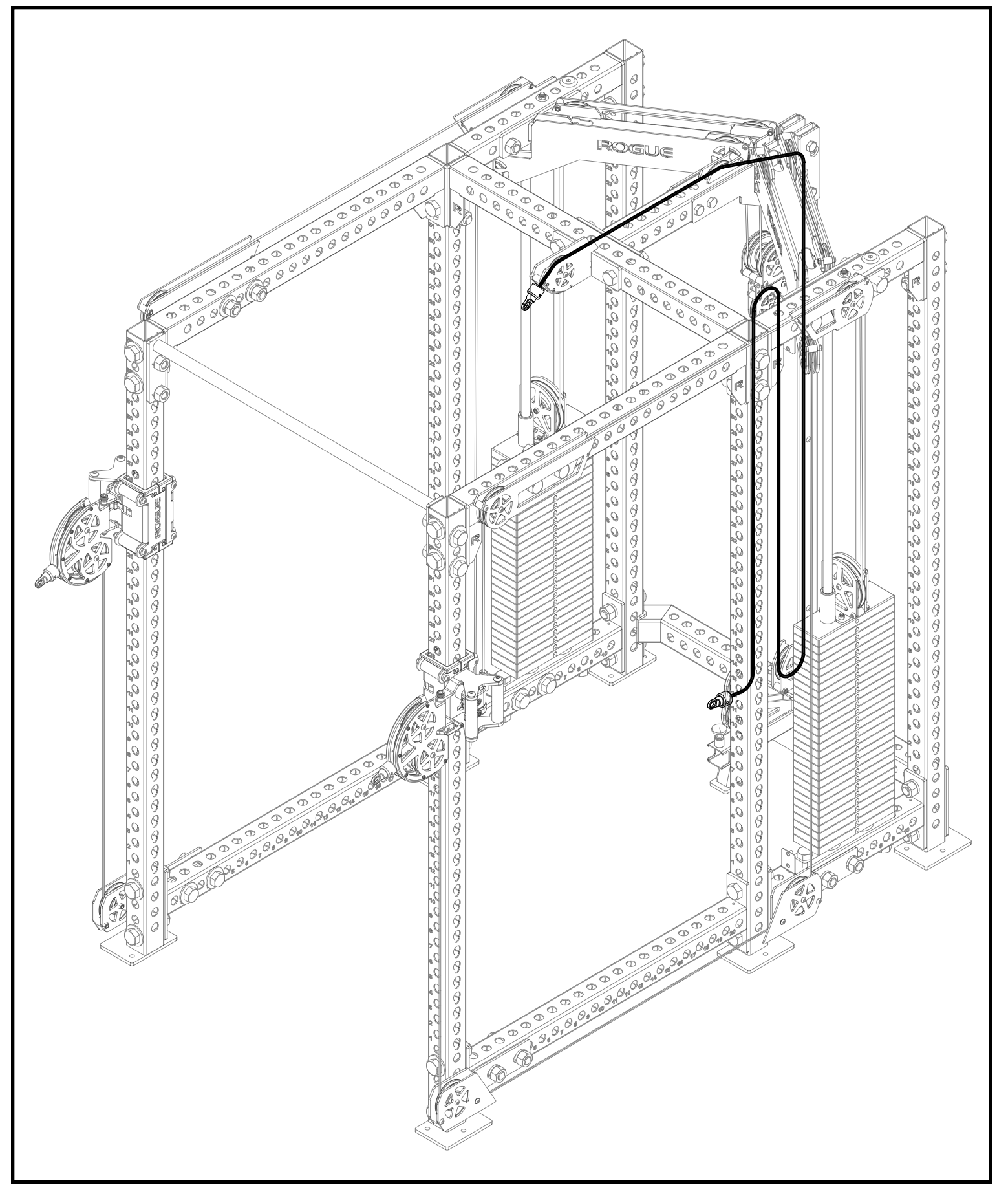

# STEP 28

## Tools Required:

- 7/32" Allen Key & 9/16" Wrench
- Disassemble pulley located at the bottom of Rear 3X3 upright and feed cable around pulley.
- Reassemble pulley while pulling cable up toward Peanut Pulley.
- Feed cable around bottom pulley in the Peanut Pulley [47] and then back down again.
- Feed cable out through the front of the Low Row Footplate Assembly [27] and assemble Clevis onto Ball End of cable.

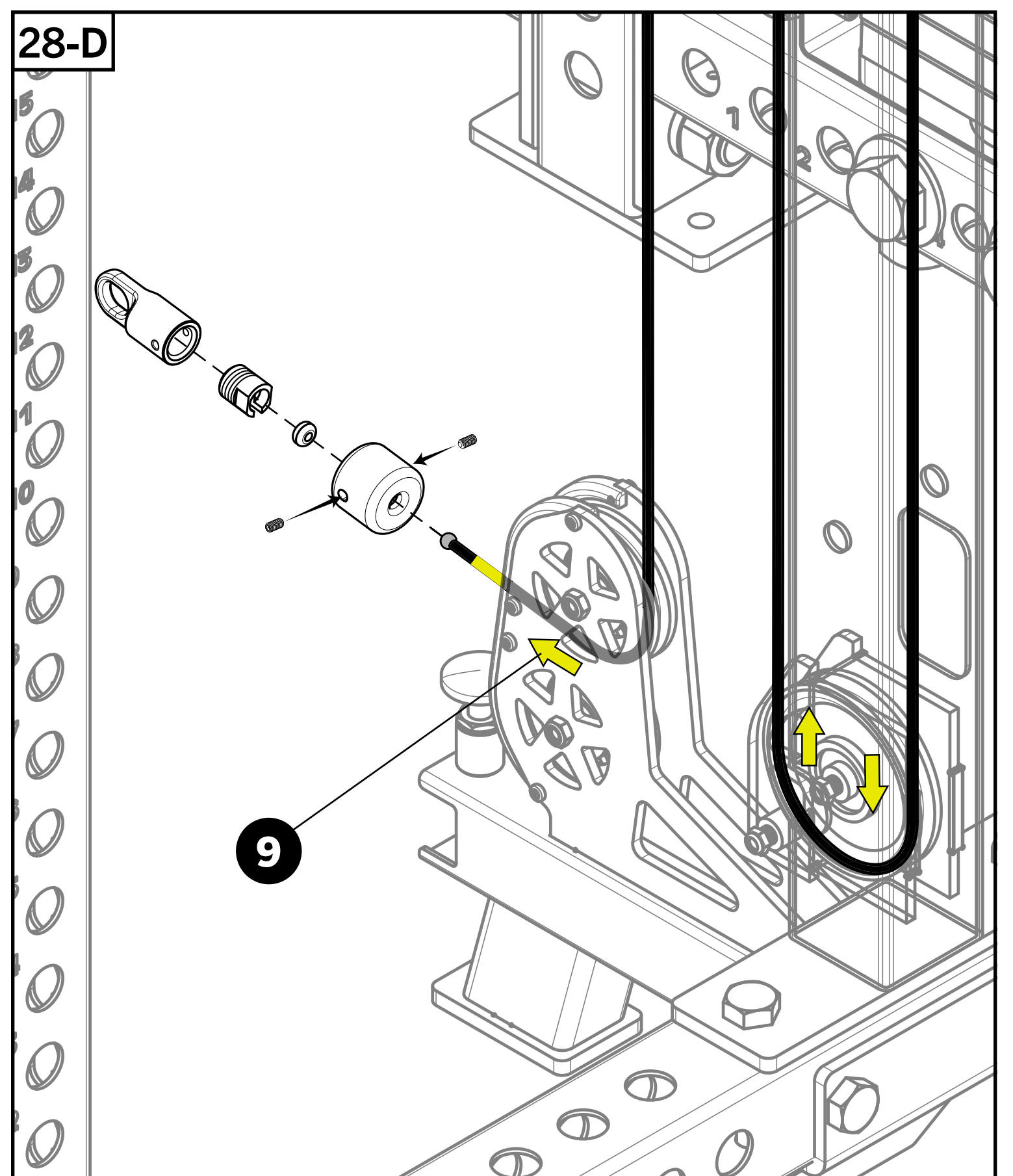
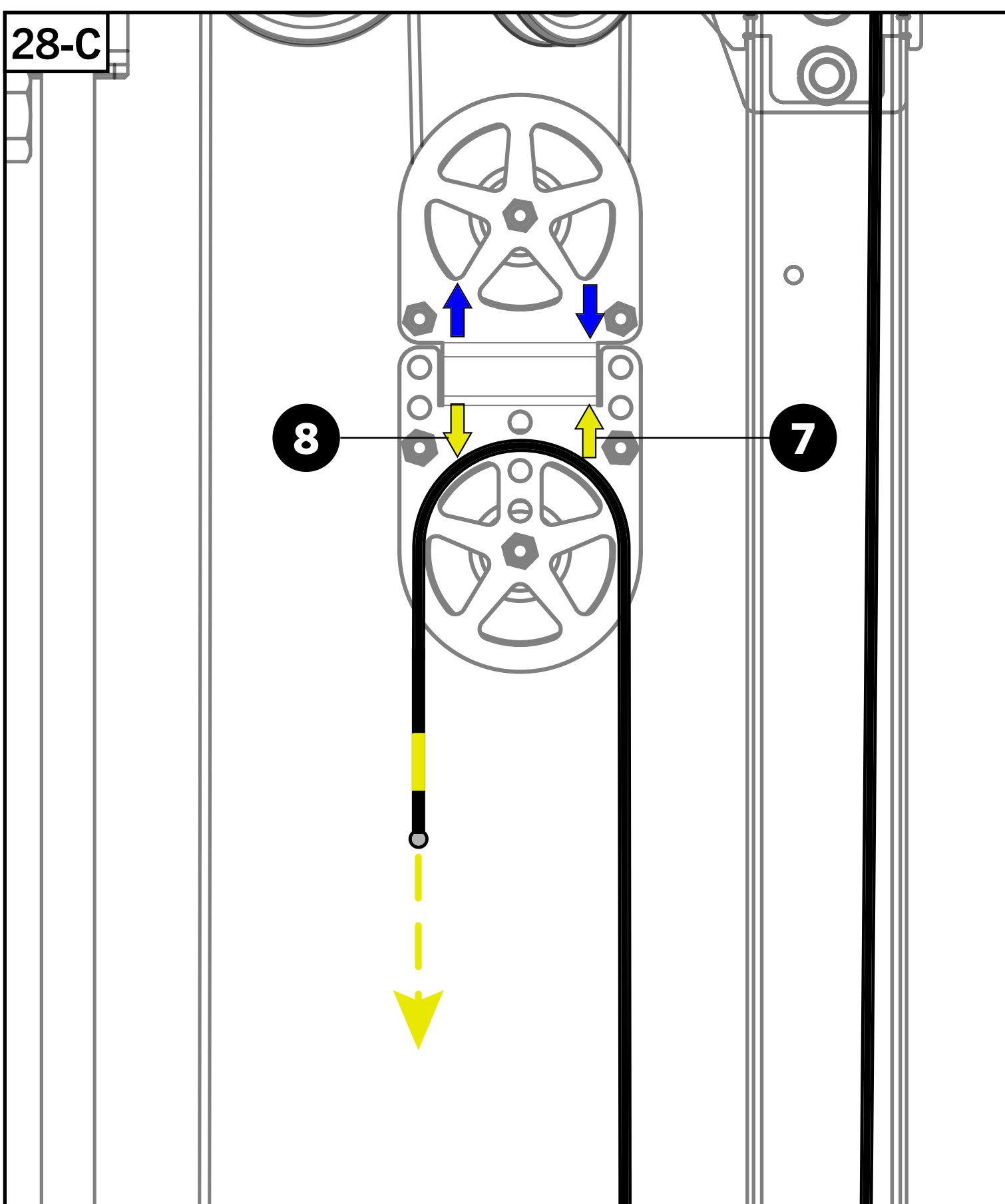
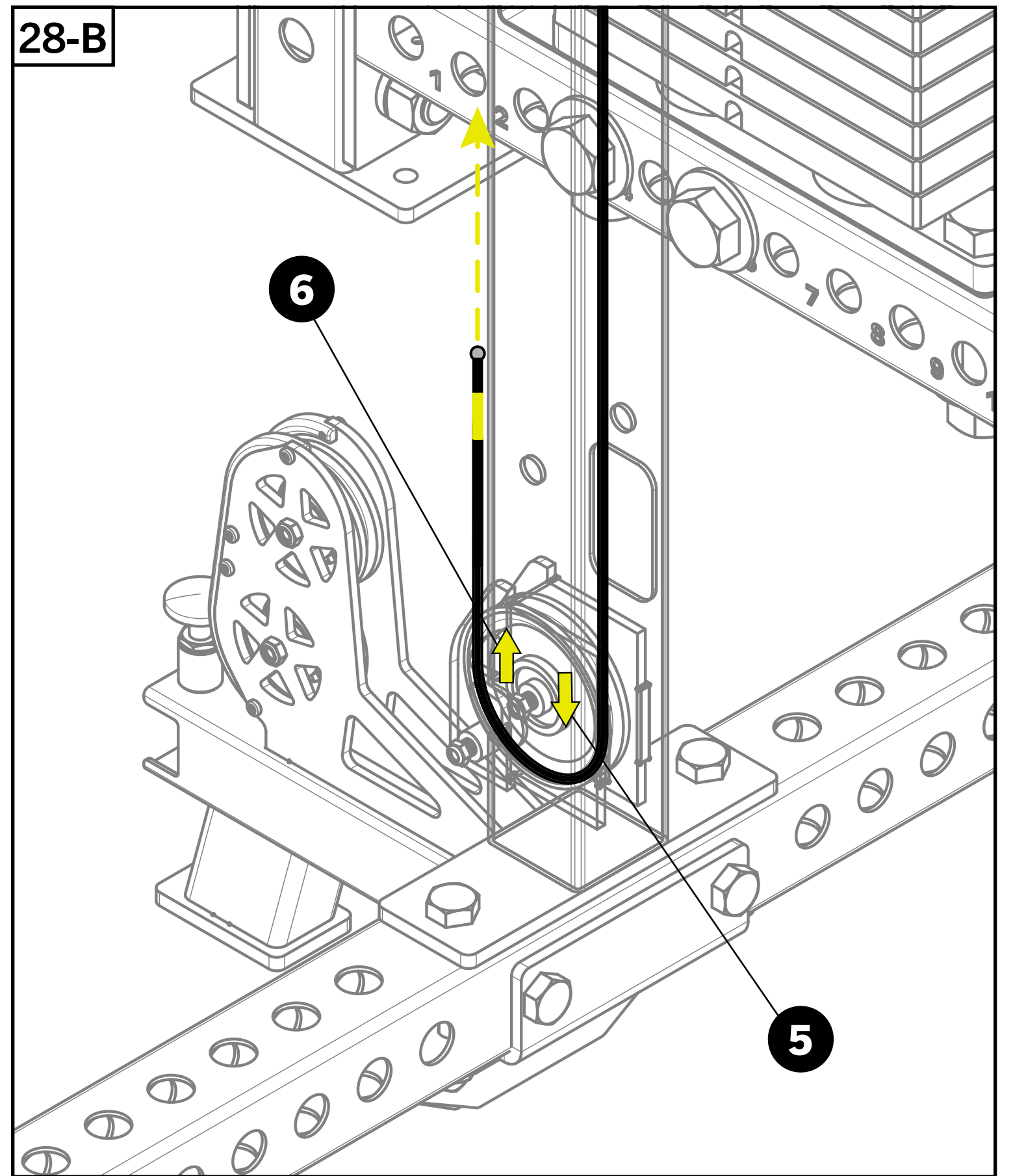
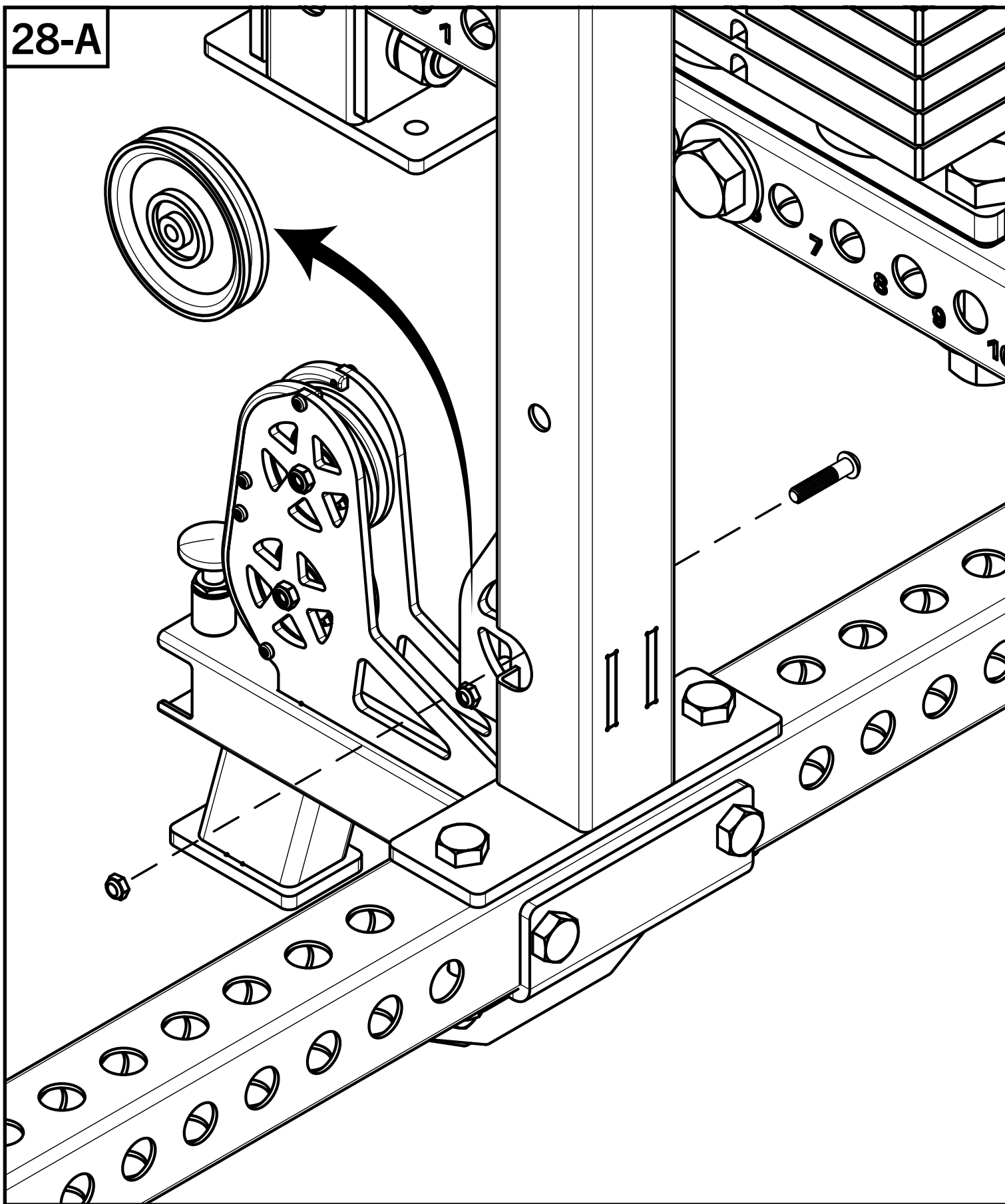
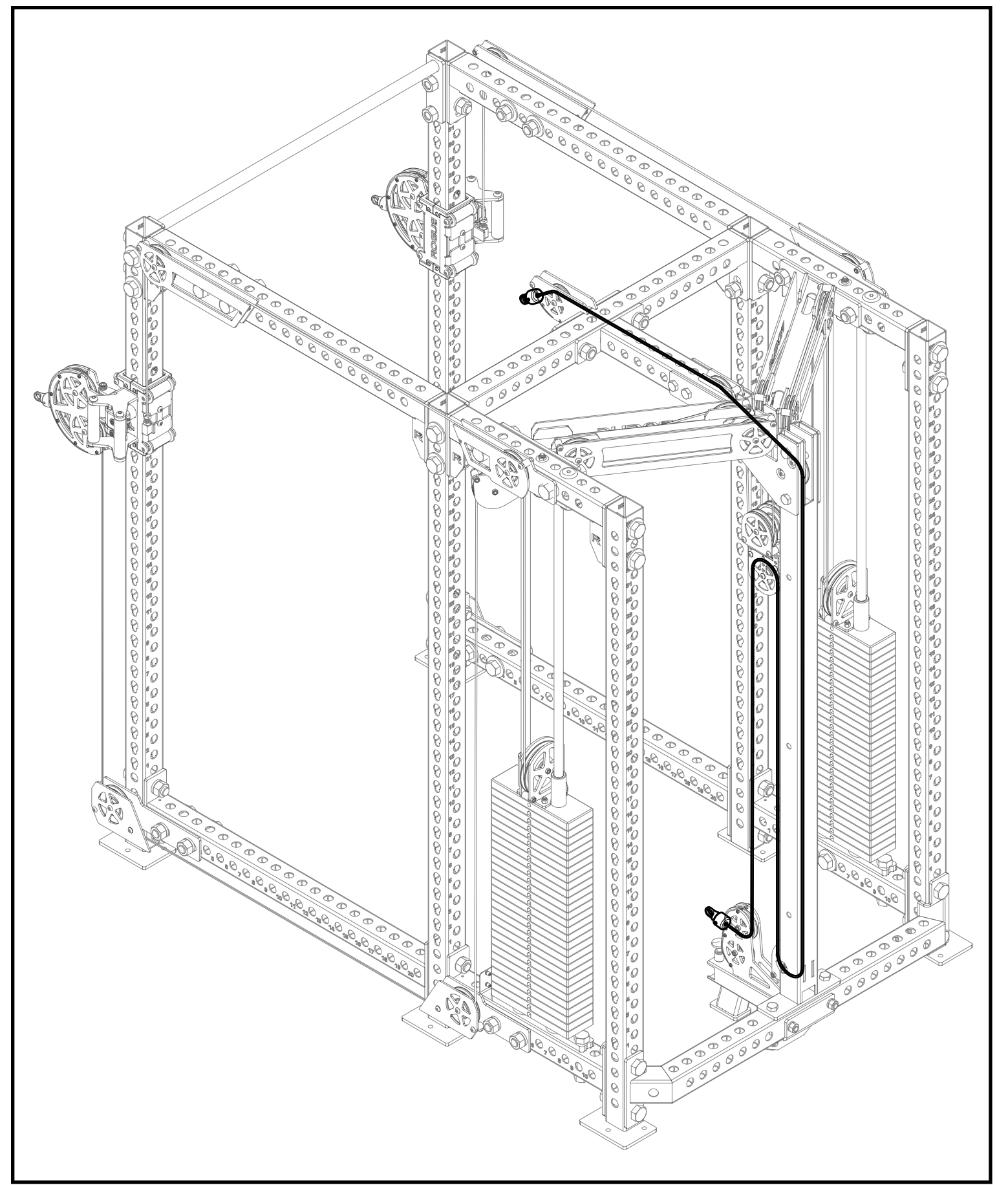

## STEP 29

### Tools Required:

- 7/32" Allen Key
- Remove eight 3/8" Button Head Screws located on the rear of the Front Side Pulley Assemblies and the front of the Rear Side Pulley Assemblies.
- Fasten the Top Cable Cover Rails [37] between the Front and Rear Top Side Pulley Assemblies by aligning holes and reinstalling the 3/8" Button Head Screws.
- Repeat this process on the bottom of your rack to install the Low Cable Cover Rails [38].
- **!** Note the orientation of the Rogue logos in relation to the rack. Ensure the cable opening is facing upward on the Top Cable Covers and downward on the Low Covers.

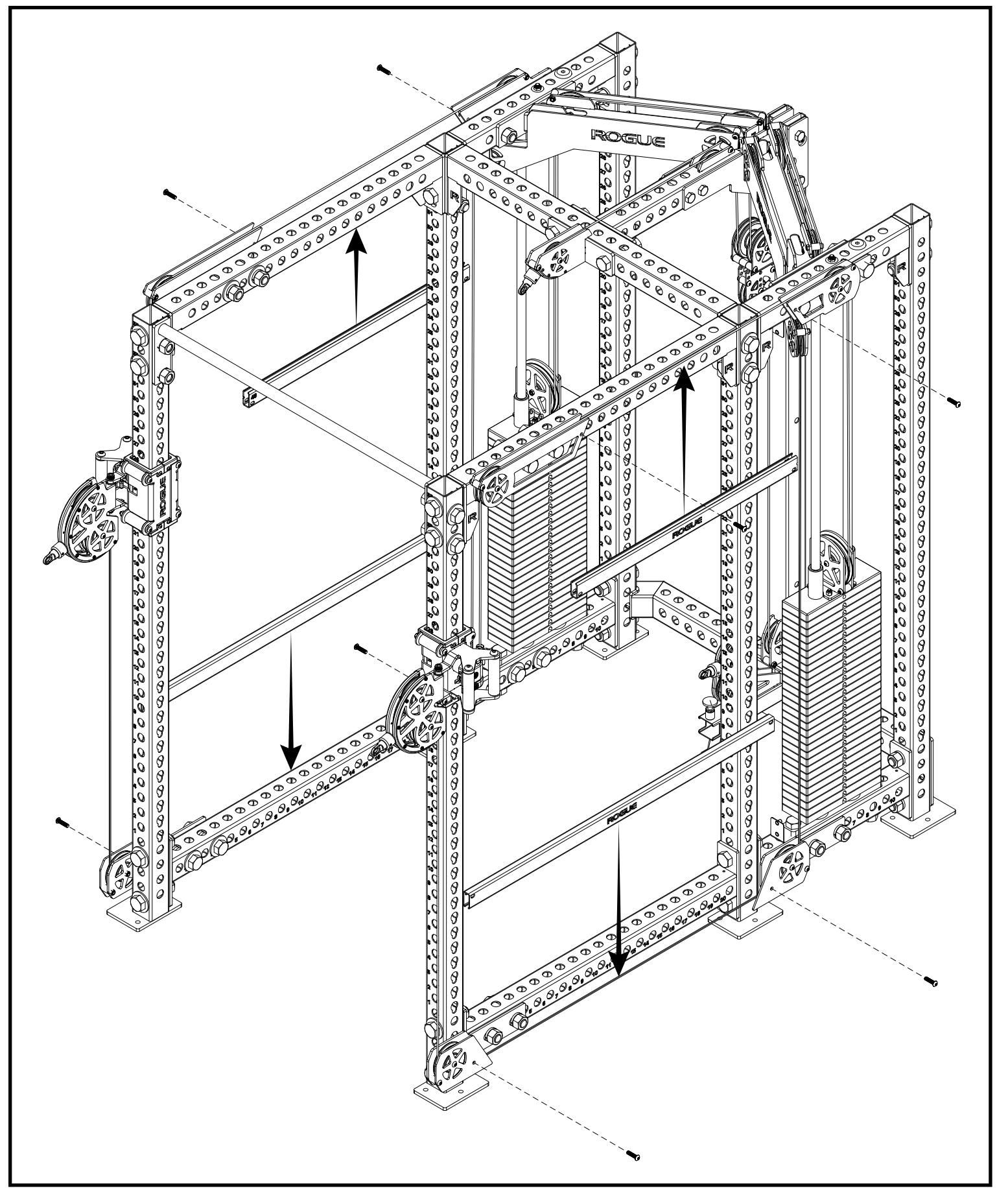

29-A

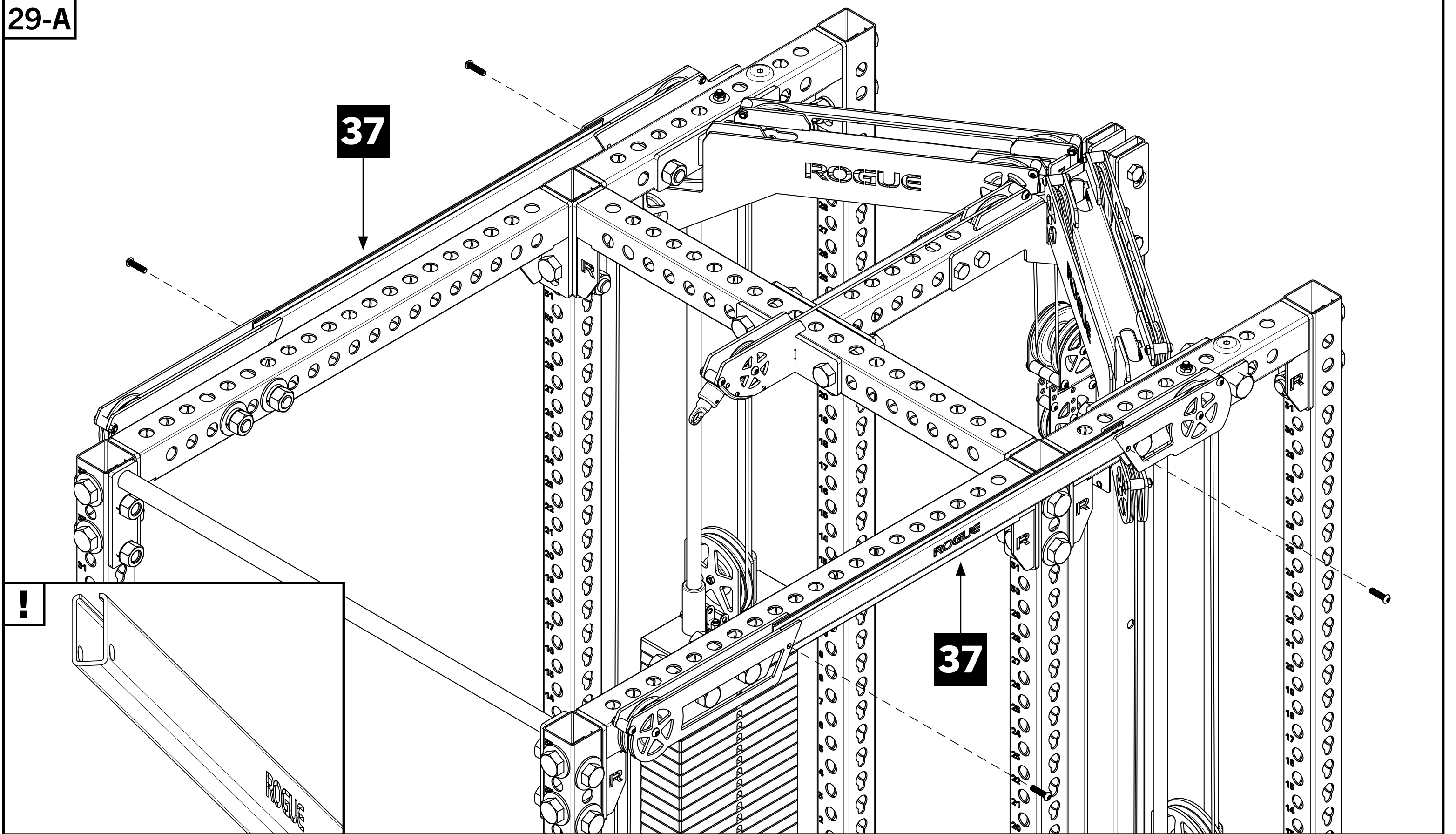

29-B

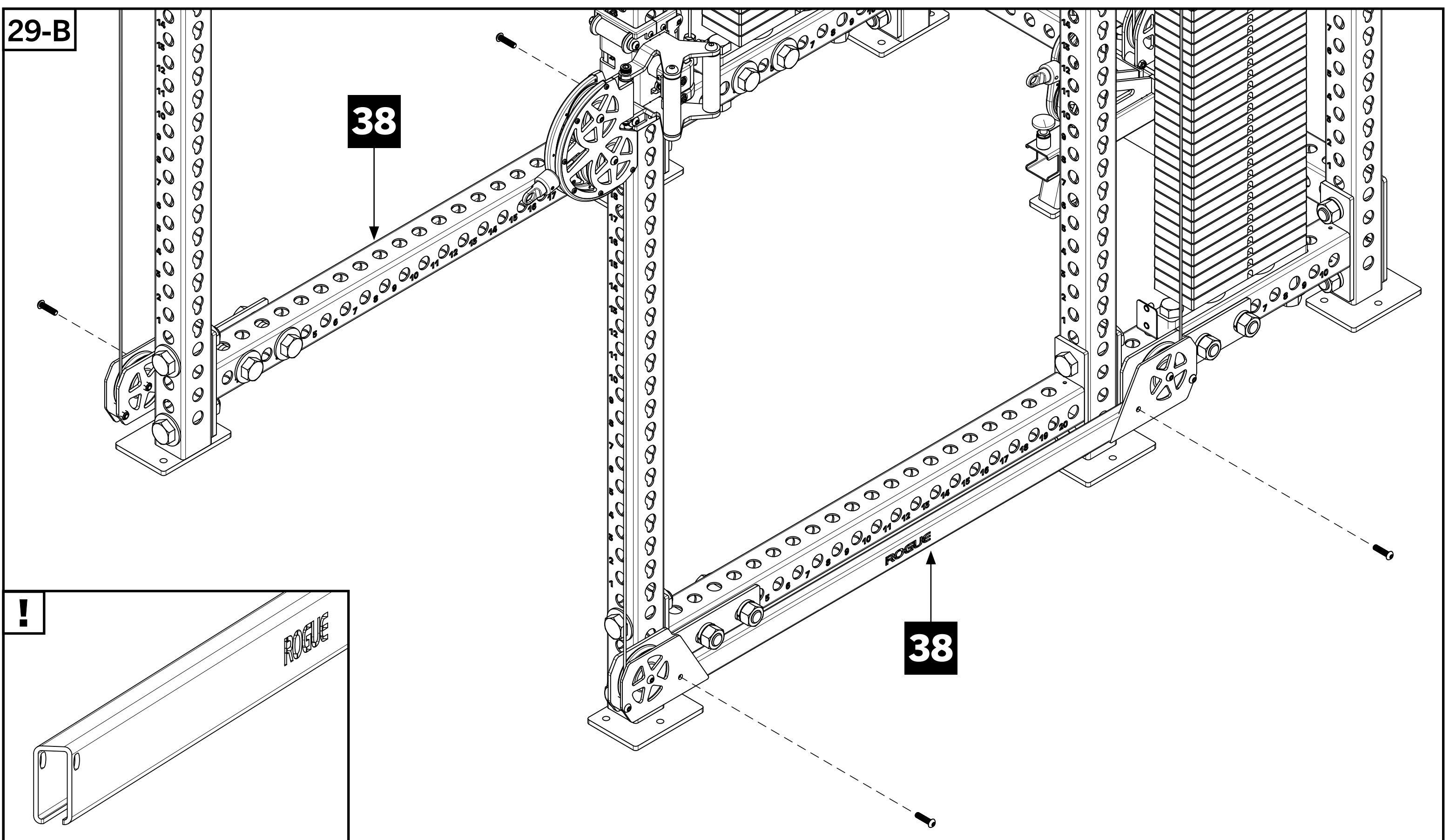

# STEP 30

## Tools Required:

- 1-1/2" Wrench, 1/8" Allen Key
- If modifying existing rack with add-on kit, skip to **30-B**.
- Place Key Washer over the Key Nut on the Plate Storage Post shown in **Detail** view.
- Assemble Plate Storage Pins [8] on rear Monster Uprights at desired hole heights.
- Slide Plate Storage Spacers [53] all the way down Plate Storage Pins with the set screws oriented on the bottom of Spacers as shown in **30-C**.
- Fully tighten set screws using 1/8" Allen Key.

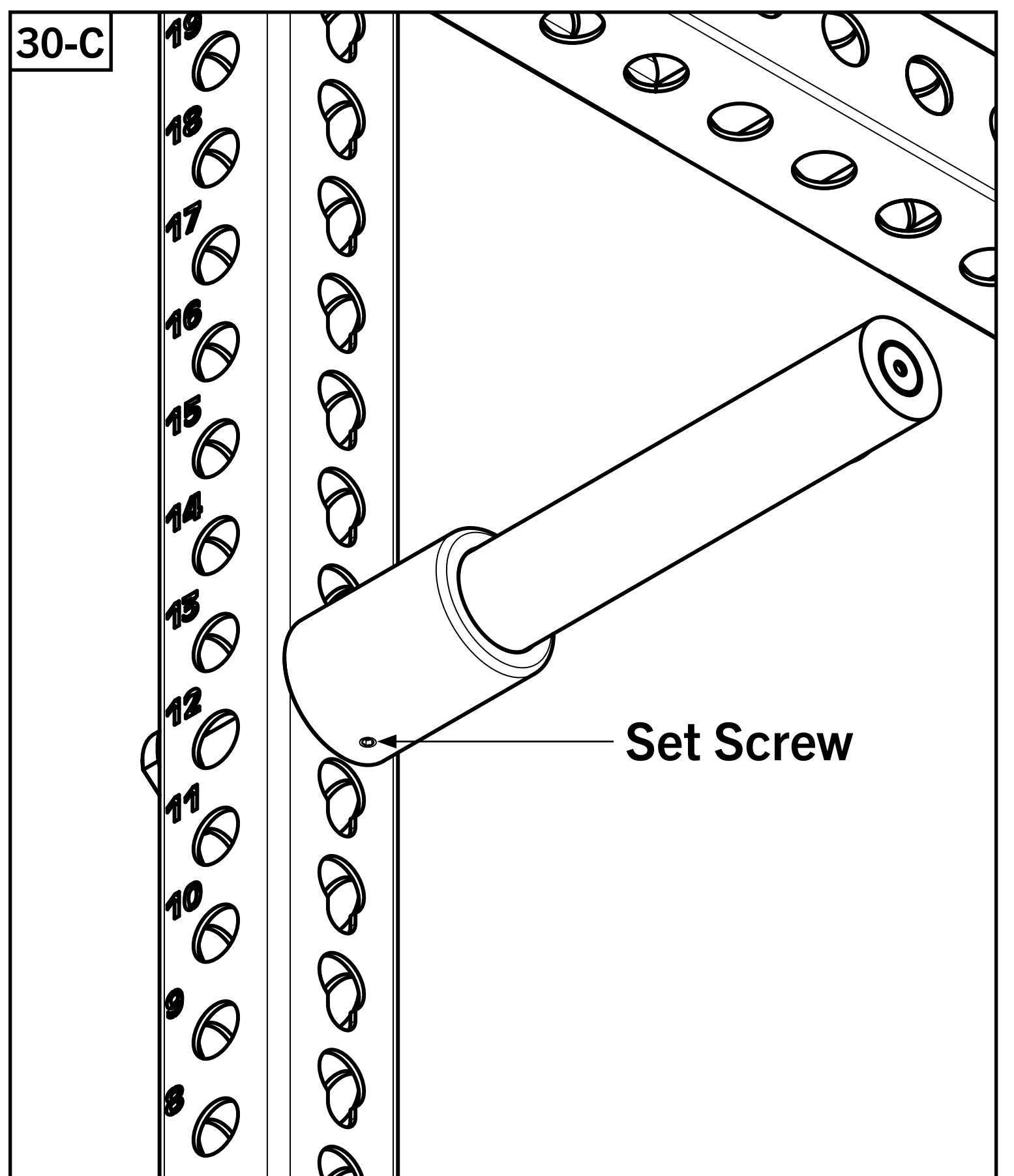
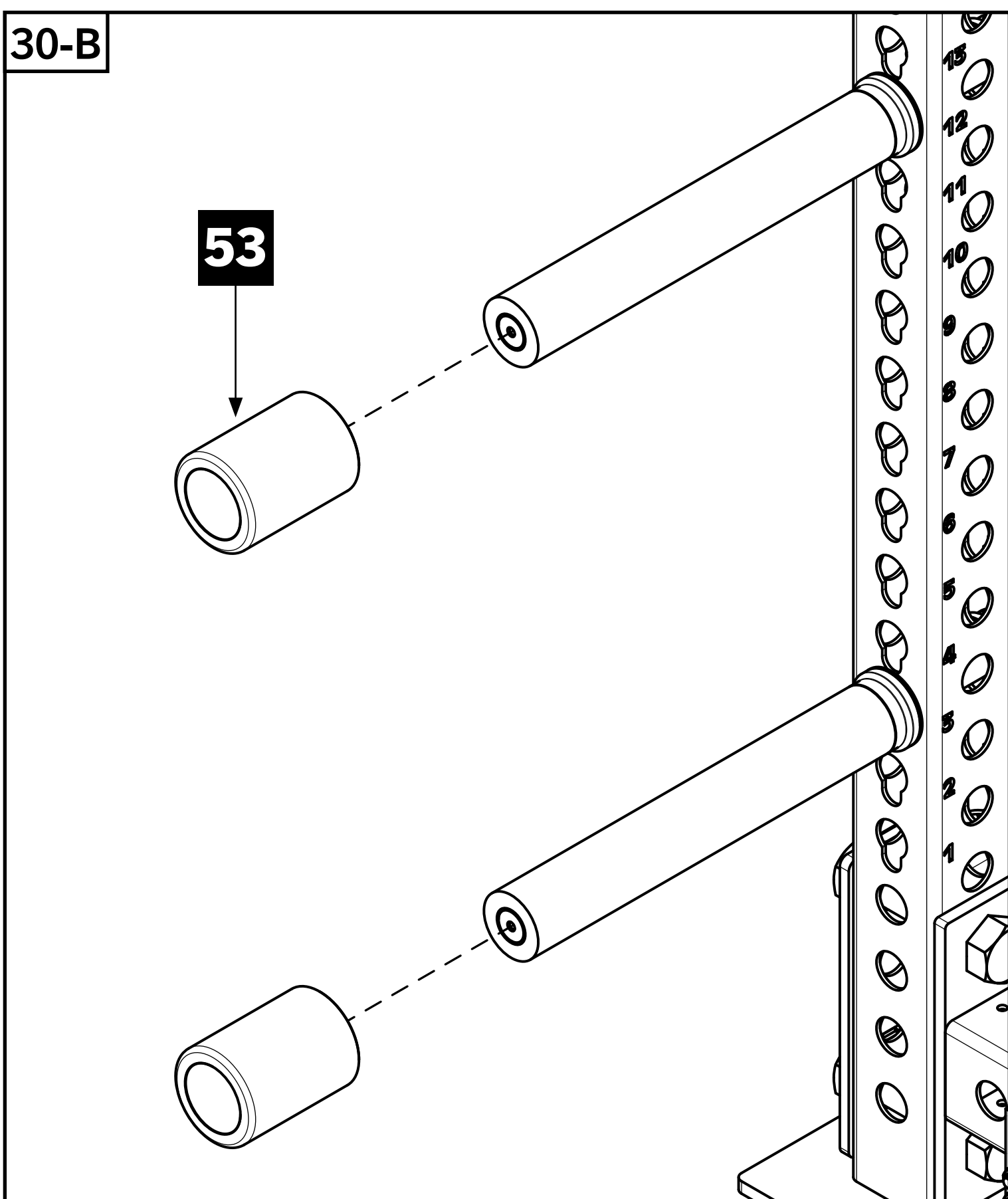
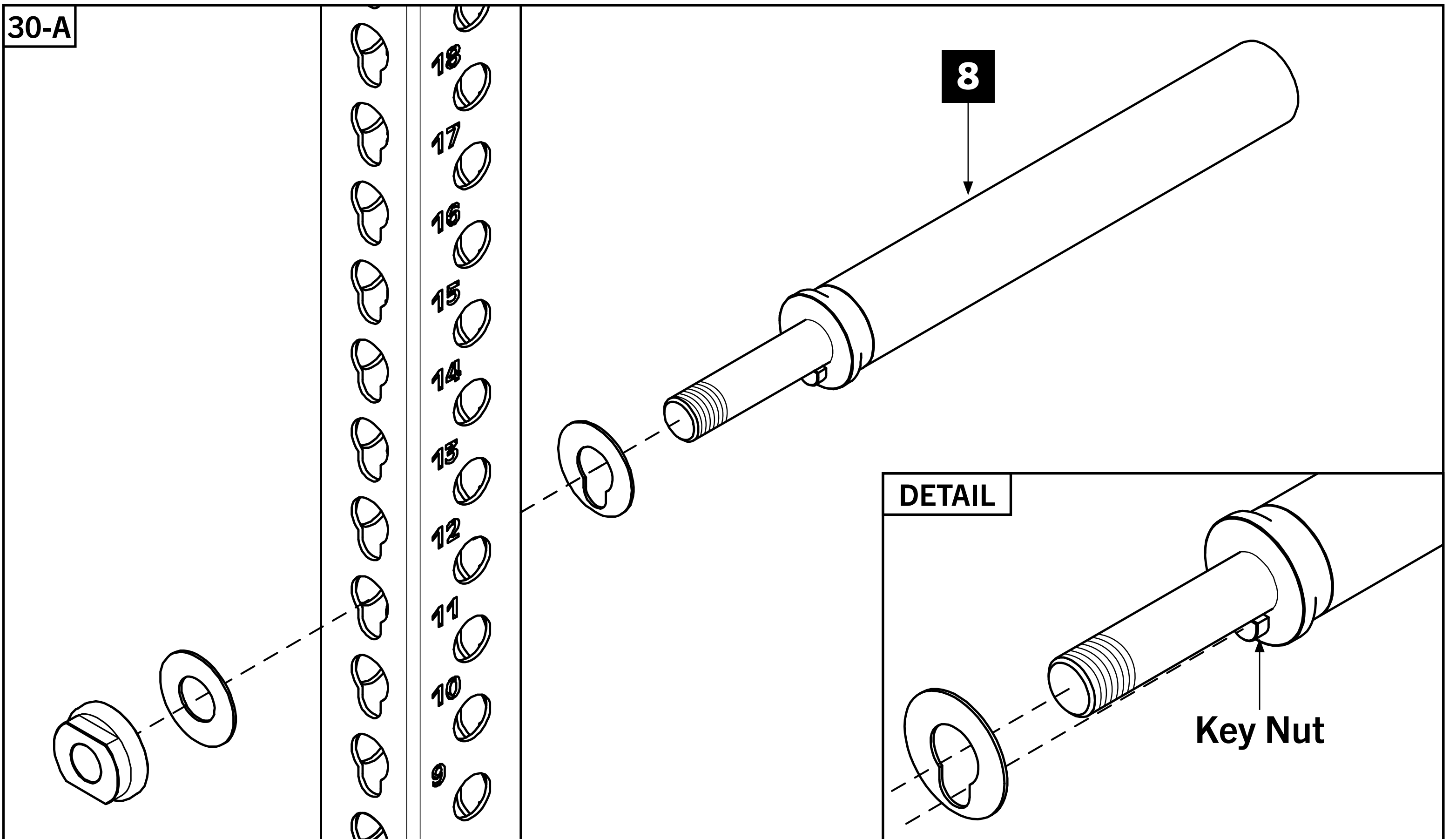
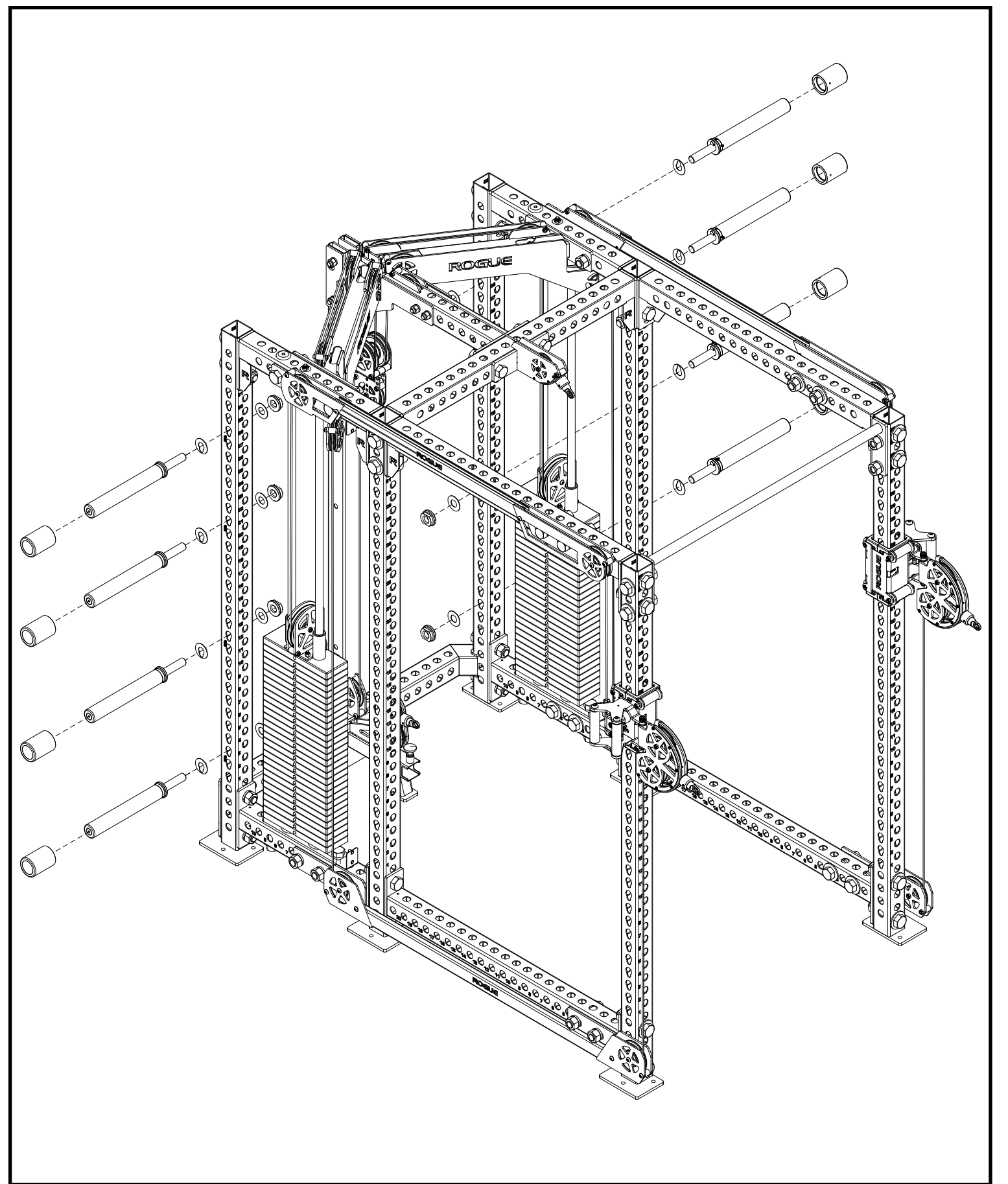

# STEP 31

## Tools Required:

- All
- Tighten ALL loose hardware on the entire rack.
- Starting with no weight selected on the Weight Stack, check cables by pulling on each clevis.

- If cables are too tight or loose, adjust accordingly by loosening or tightening the lower 1/2" Jam Nuts on back side of the Trolleys [19,20].

31-A

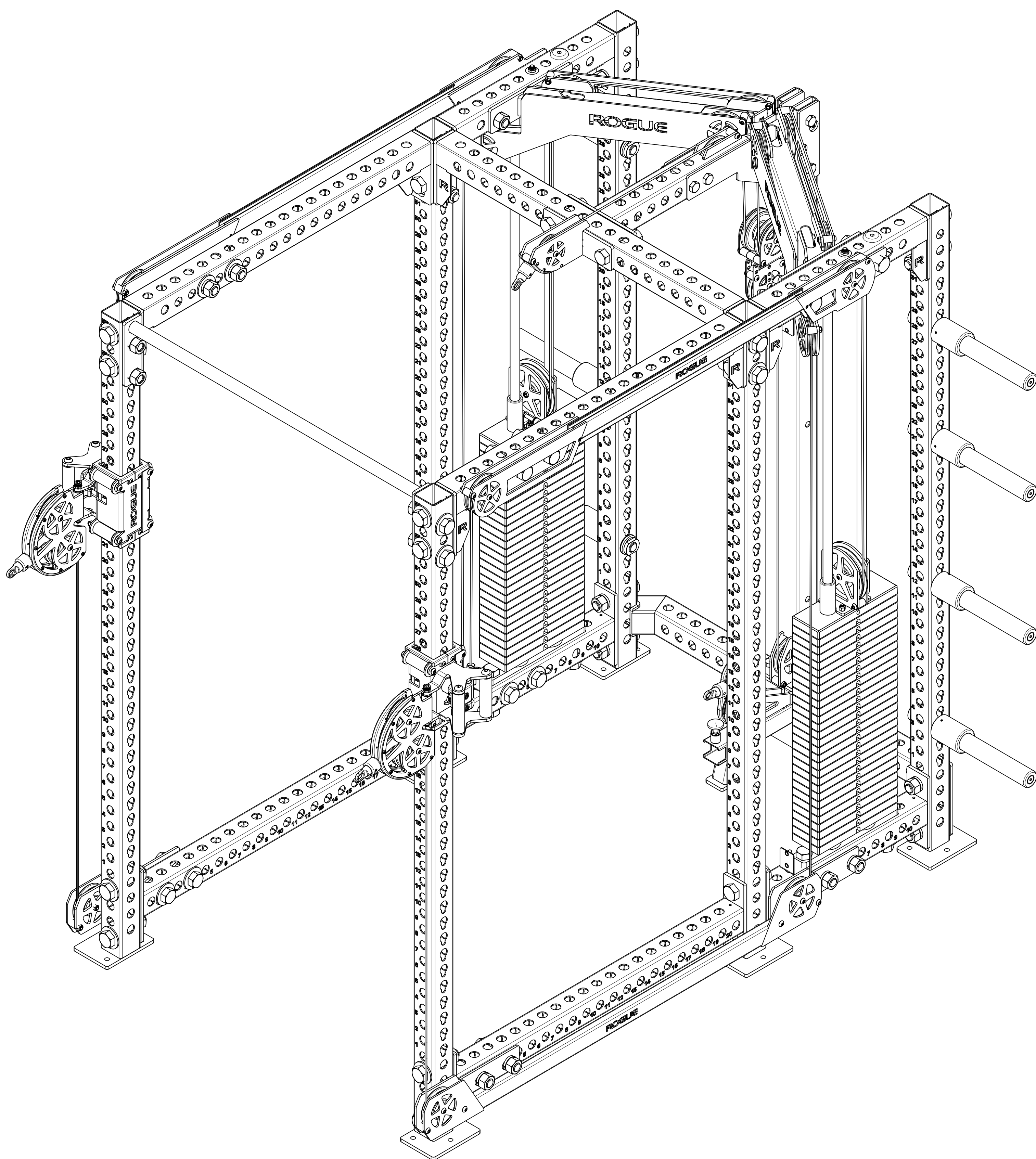

## STEP 32

- Apply the Weight Stack Number Labels [52] on the front of the Weight Stack Plates, approximately 3.5" from the edge of plate.
- Attach key ring on Selector Pin Lanyard [32] to front hole on pulley plate of the Weight Stack Stem [30].

- Attach Single Handle Attachments [56] to Swivel Trolleys using included Carabiners.
- Attach Lat Bar [54] to Lat Pull down clevis attachment point.
- Re-insert the Footplate [26] into Low Row Footplate Assembly [27] and attach Standard Grip Triangle [55] to clevis.

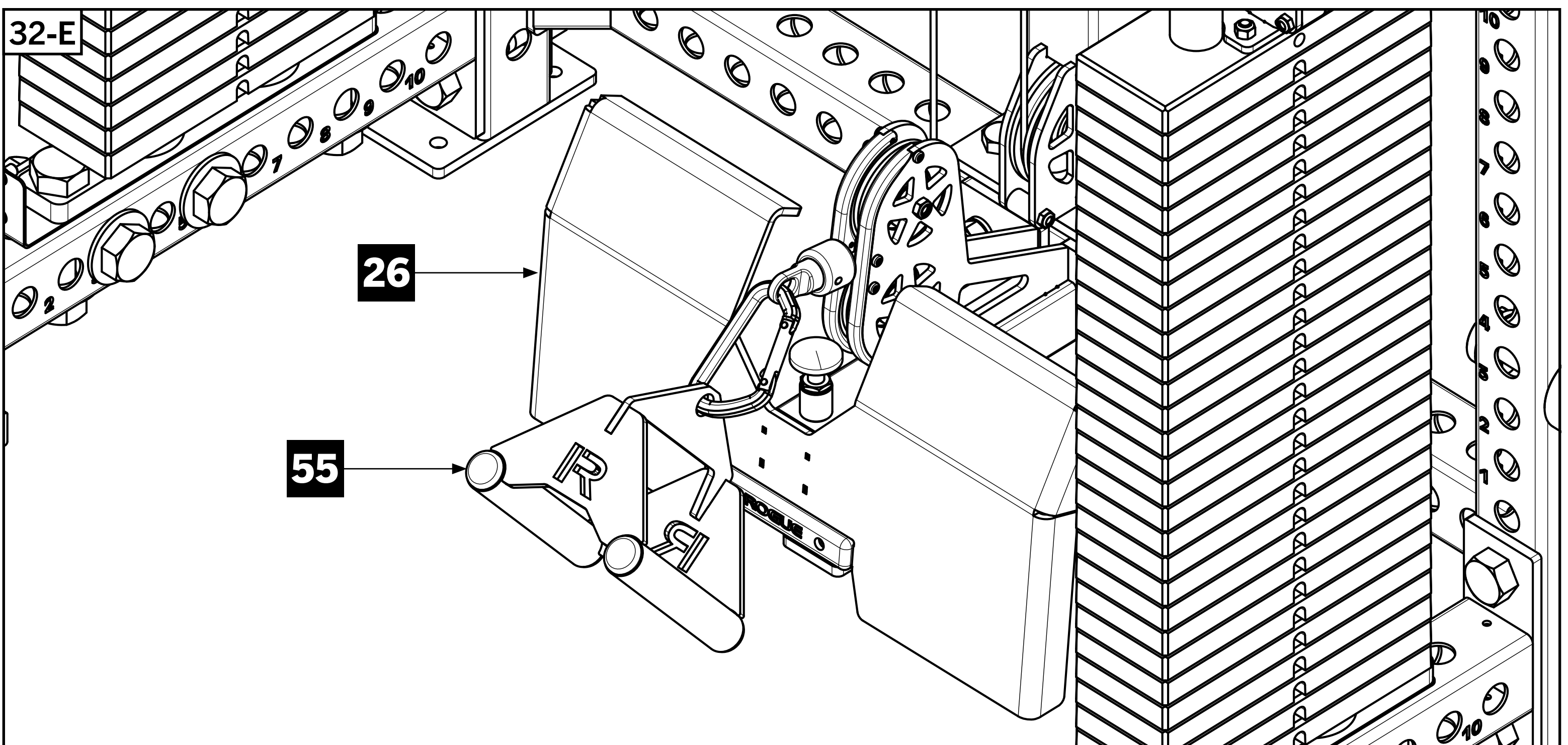
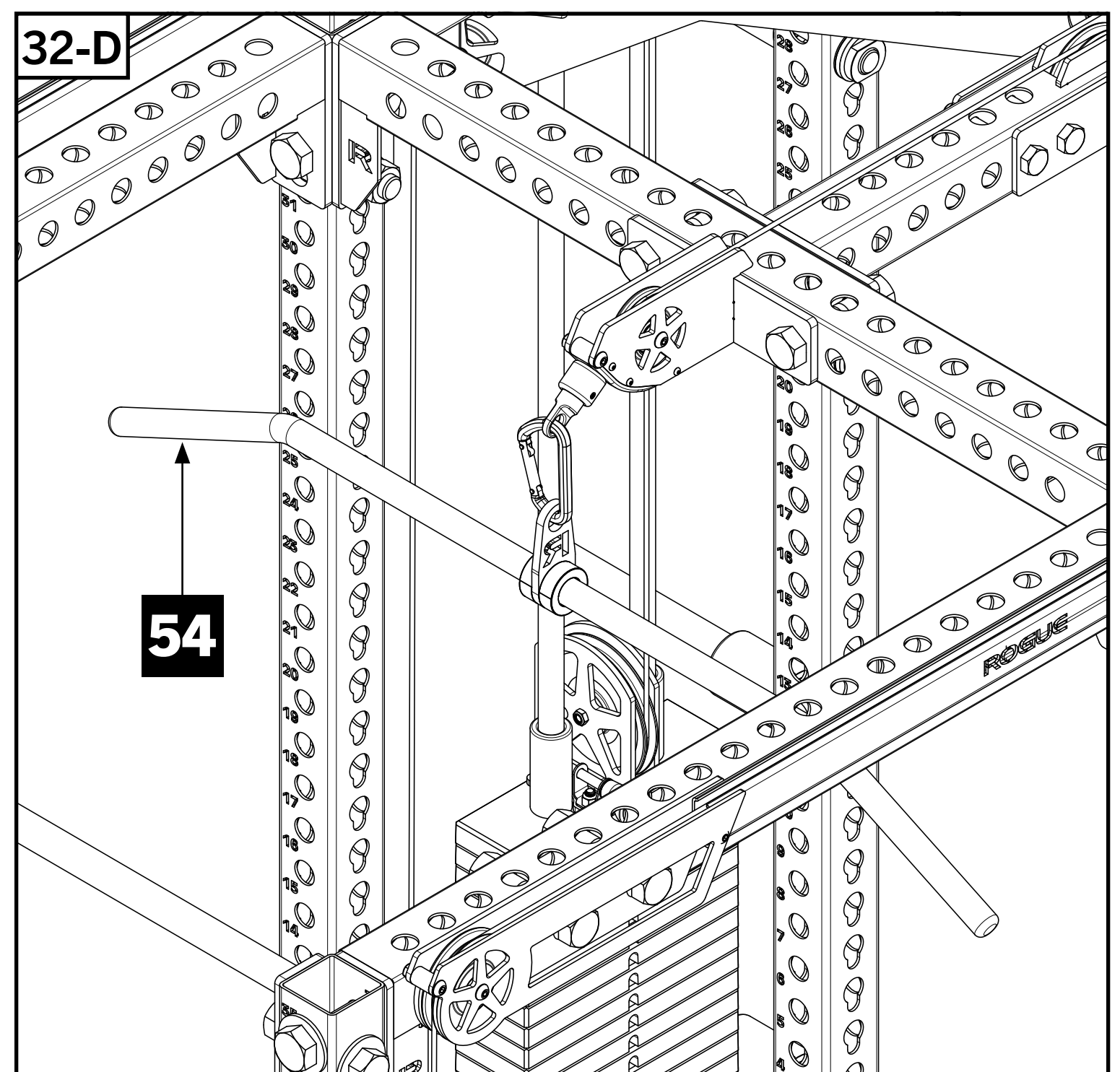
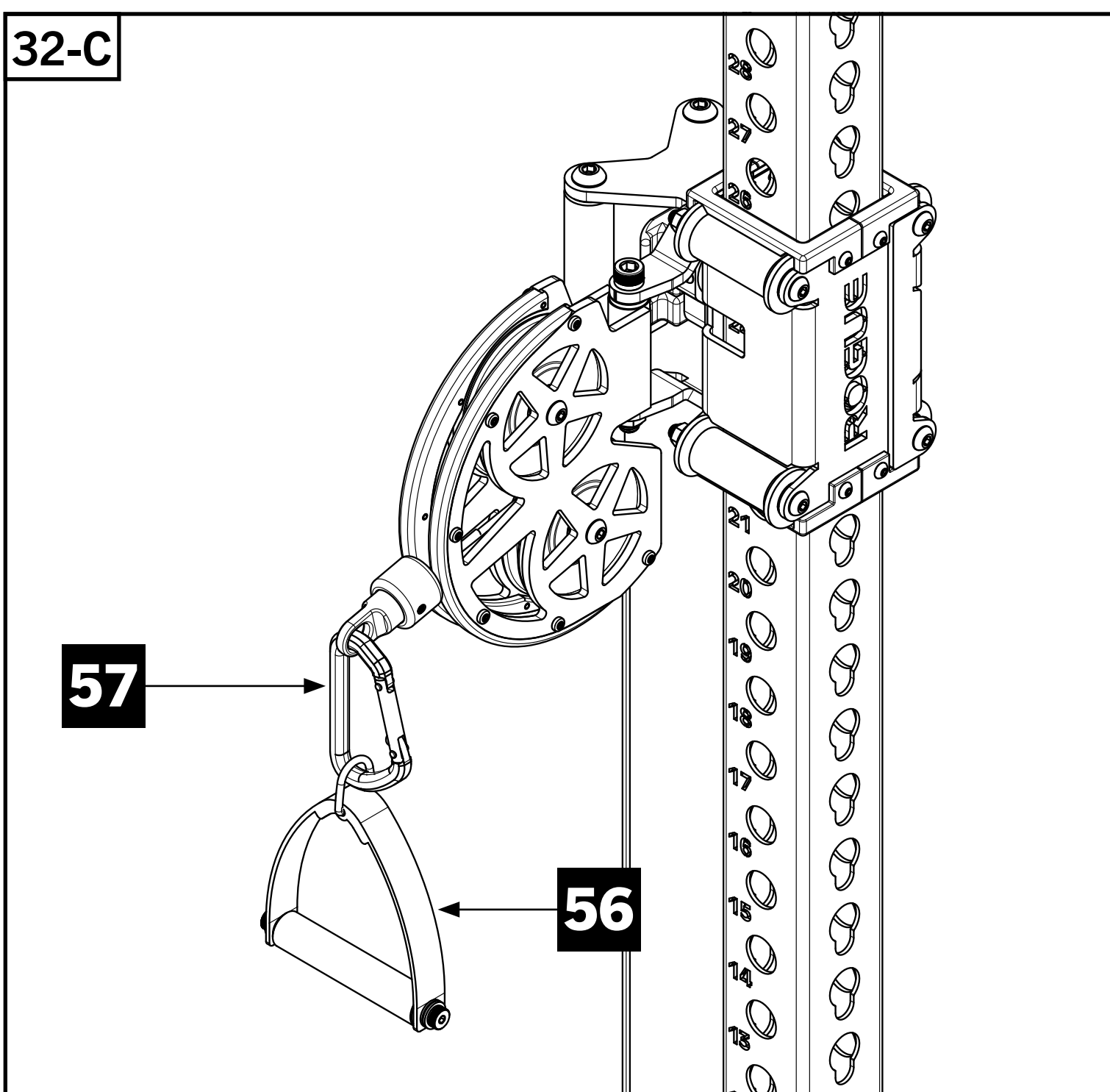
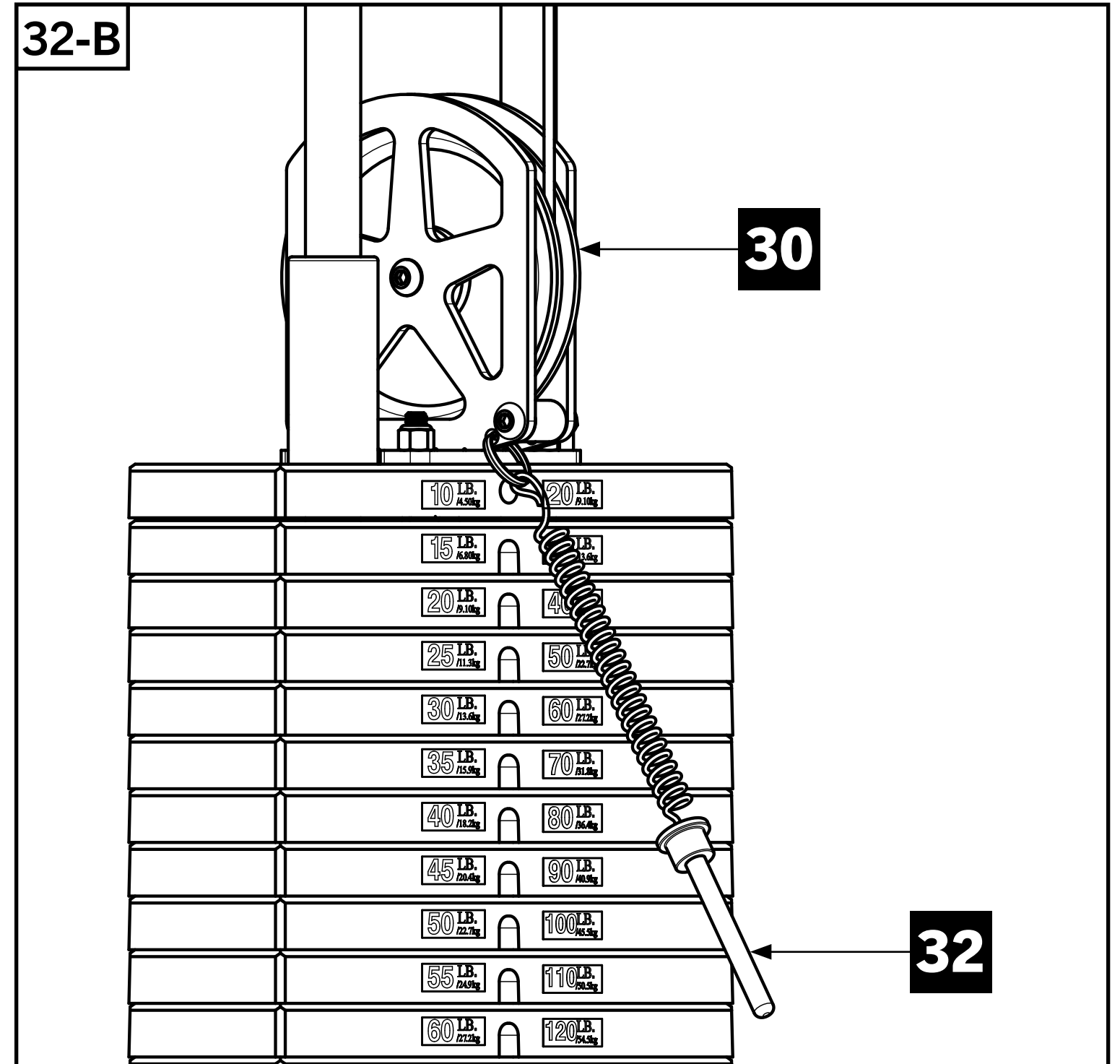
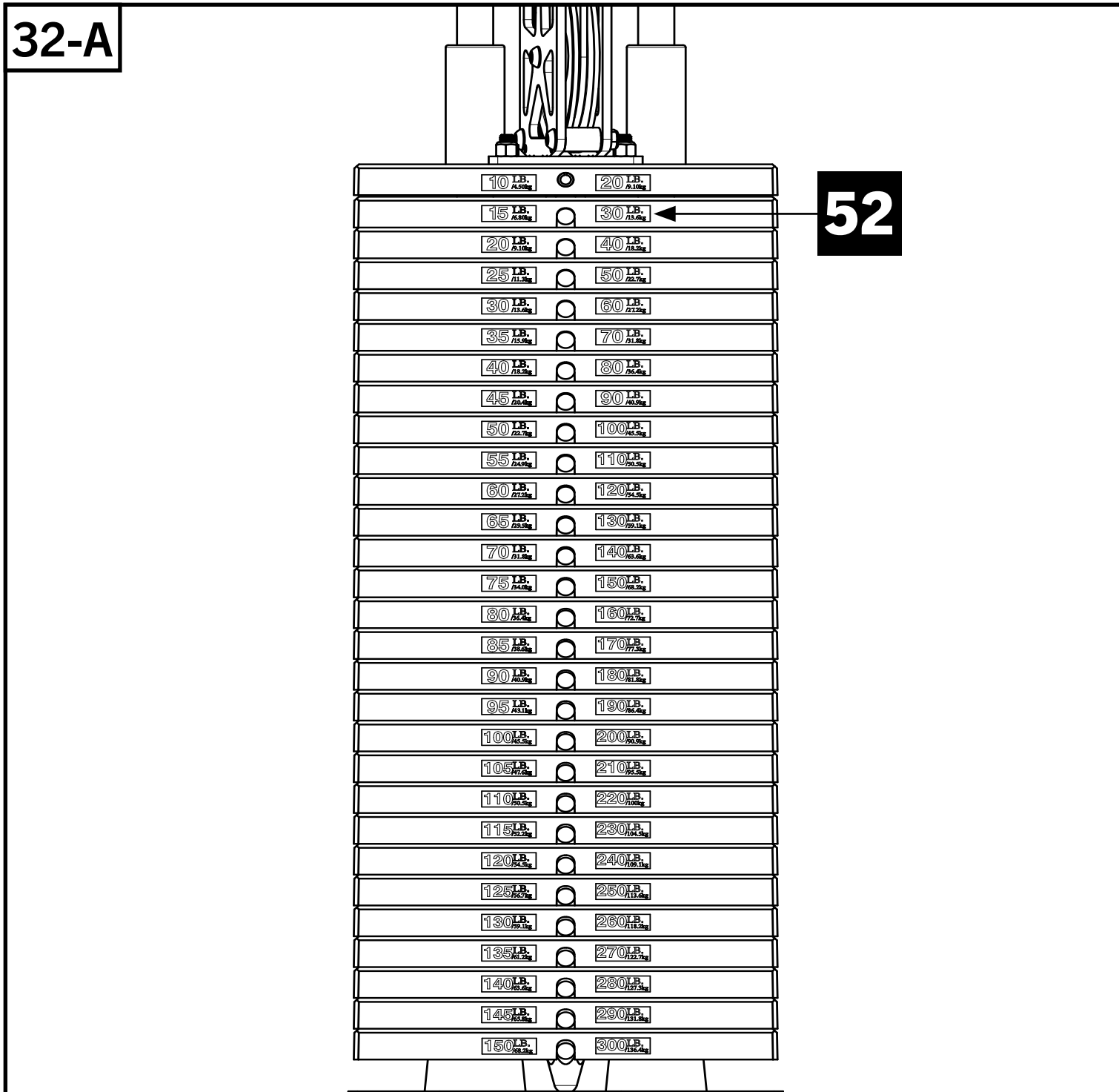

## STEP 33 (SHROUD ASSEMBLY)

- Align Rear Shroud - RH [77] and Rear Shroud - LH [78] with corresponding holes on Rear 3X3 Upright [17] and bolt Shrouds to Upright using 5/8" x 4-1/4" Hex Bolts [87], 5/8" Lock Washers [88] and 5/8" Hex Nuts [89].
- Align top and bottom 1/4" holes on Shrouds and bolt together using 1/4" x 5/8" Button Head Screws [90].

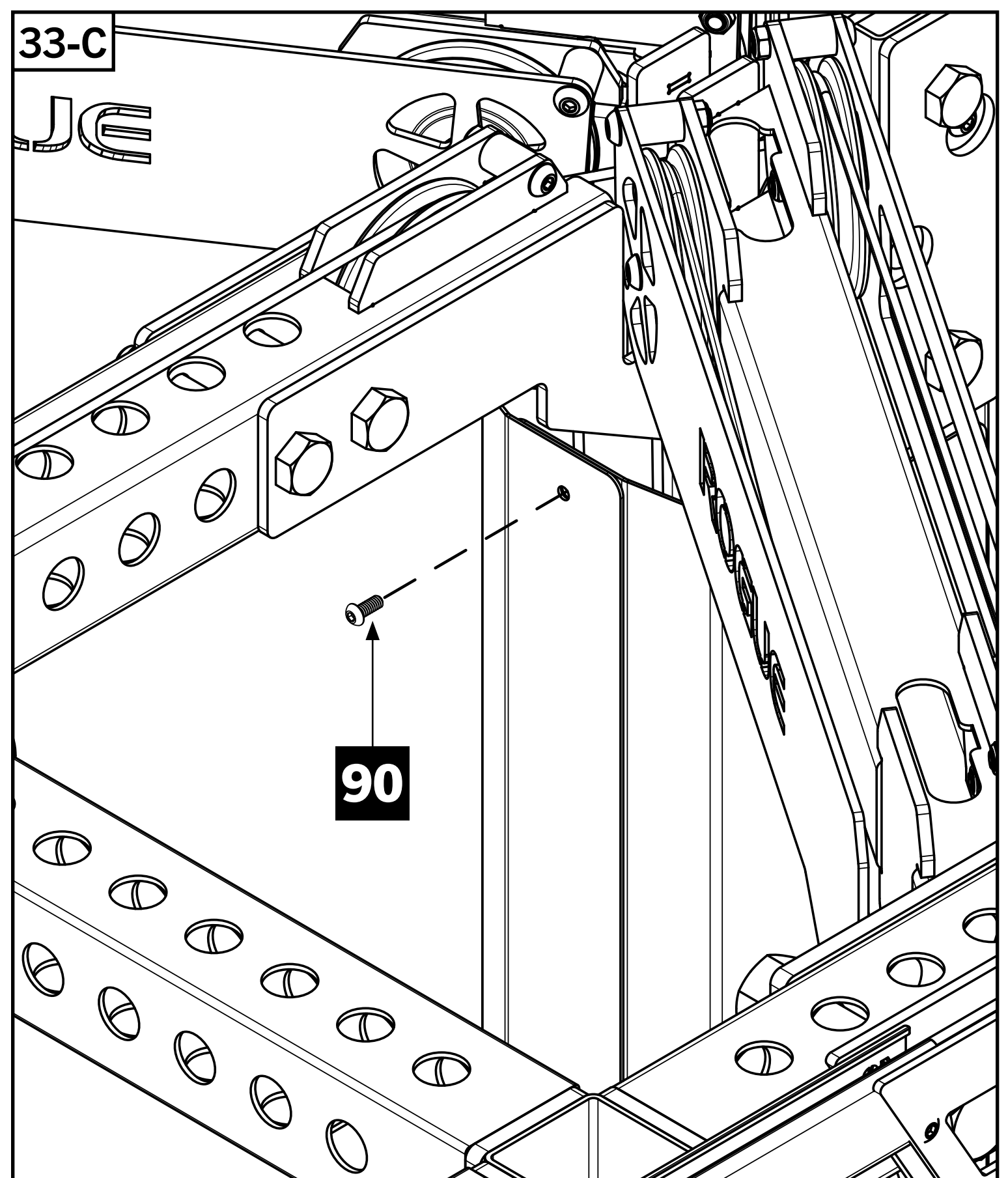
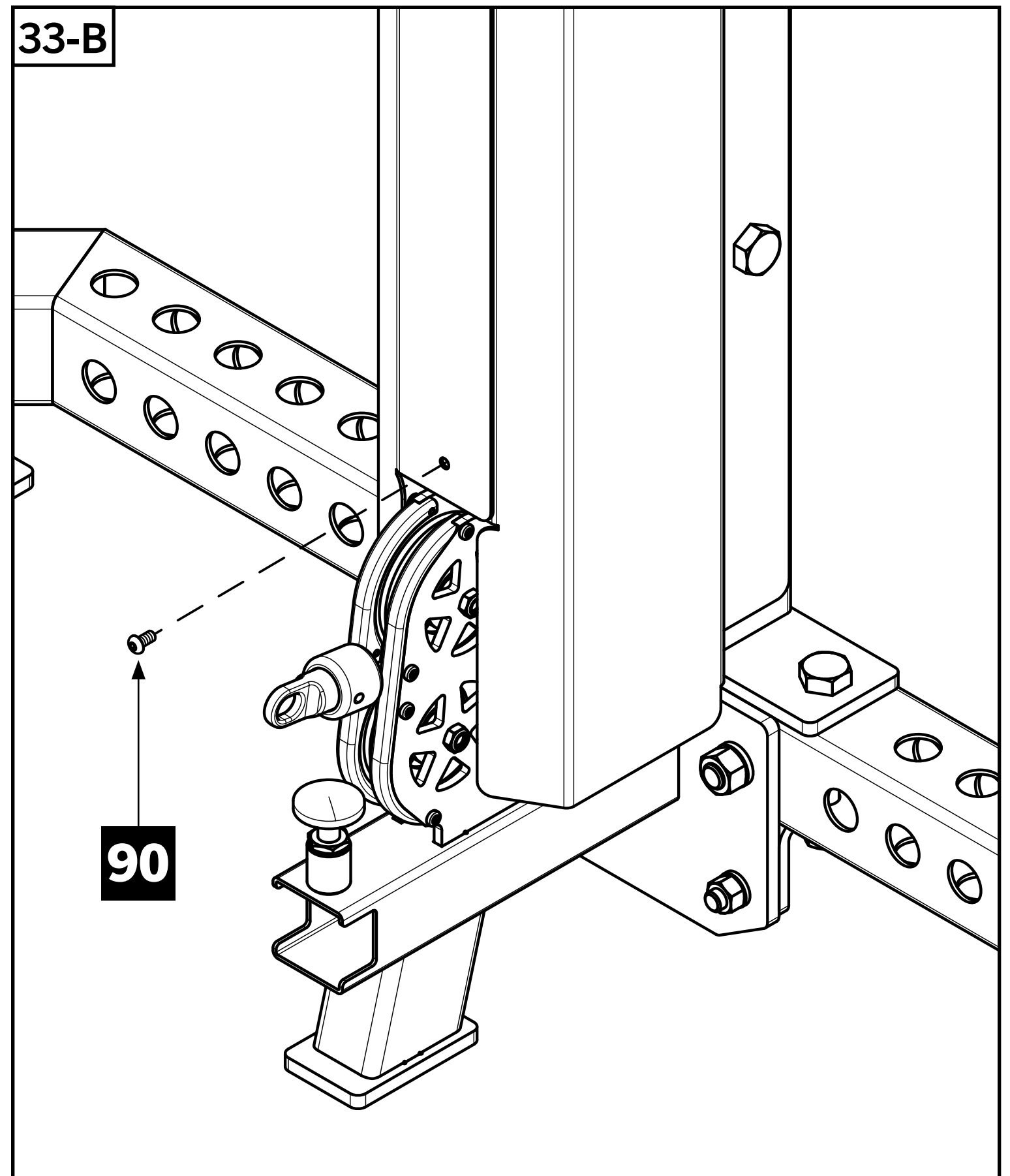
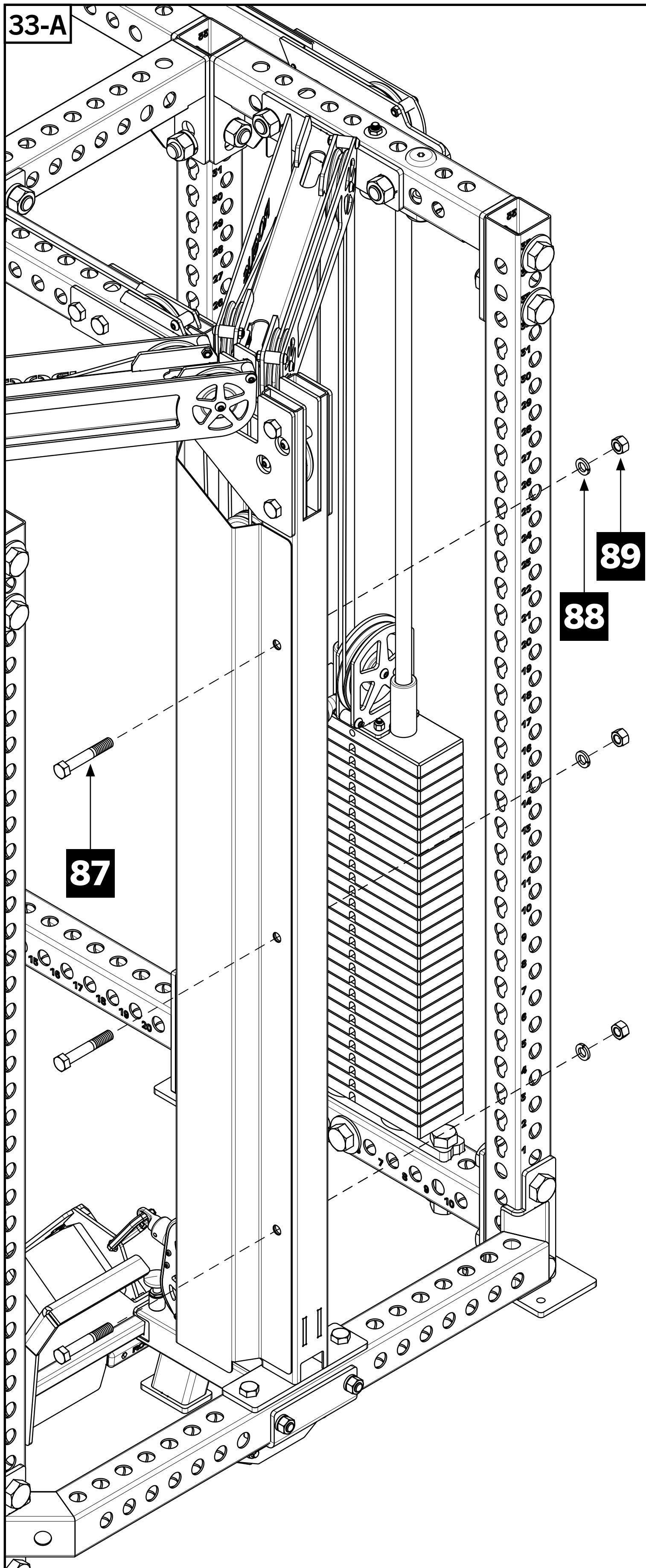
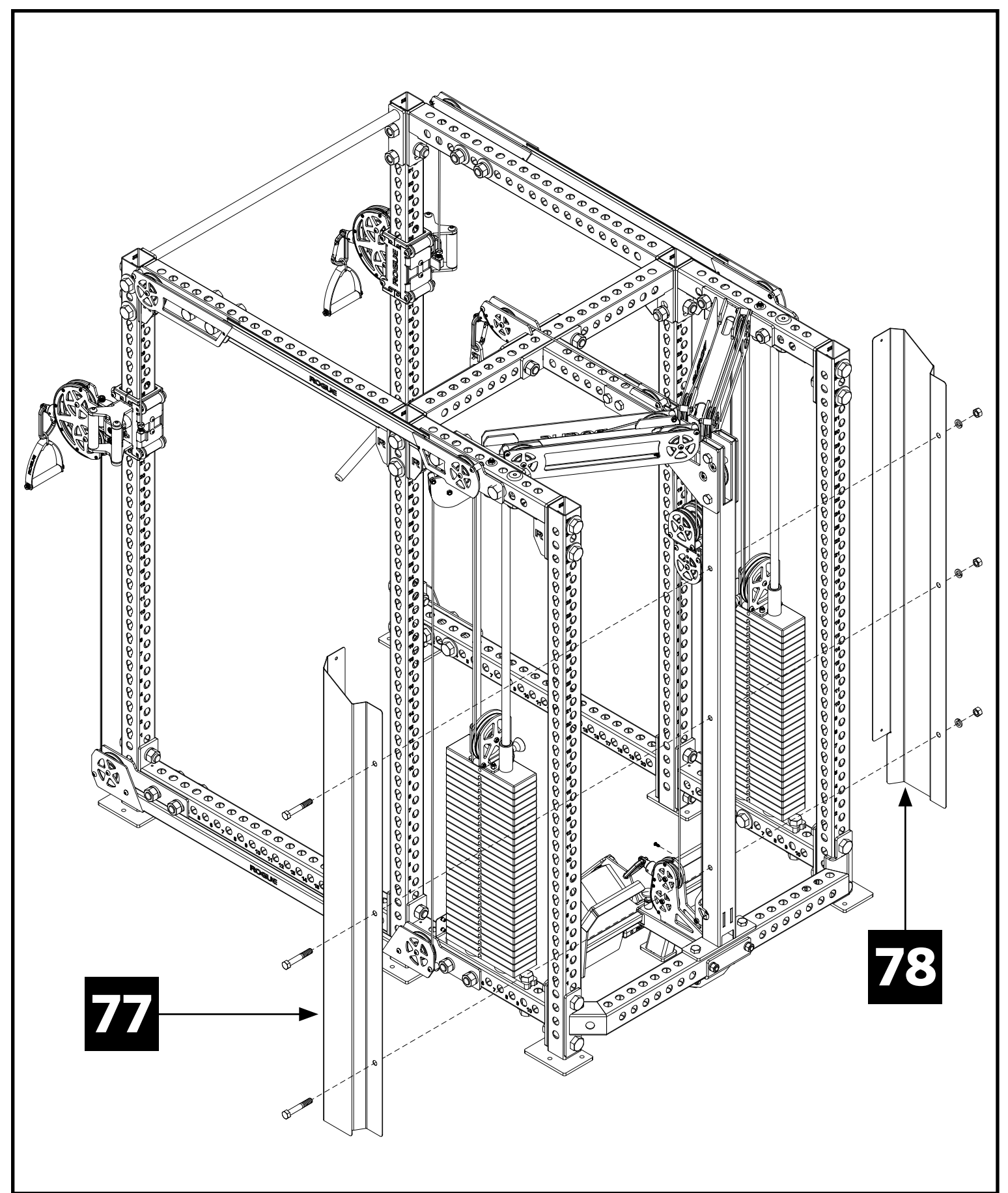

# STEP 34 (SHROUD ASSEMBLY)

- Attach Weight Stack Rear Shroud - RH [80] and Weight Stack Rear Shroud - LH [81] on rear uprights by placing 1" Lock Washers [85] and 1" Hex Nuts [86] through window cutouts on shrouds and secure using 1" Flat Washers [84] and 1" x 4-3/4" Hex Bolts [83].

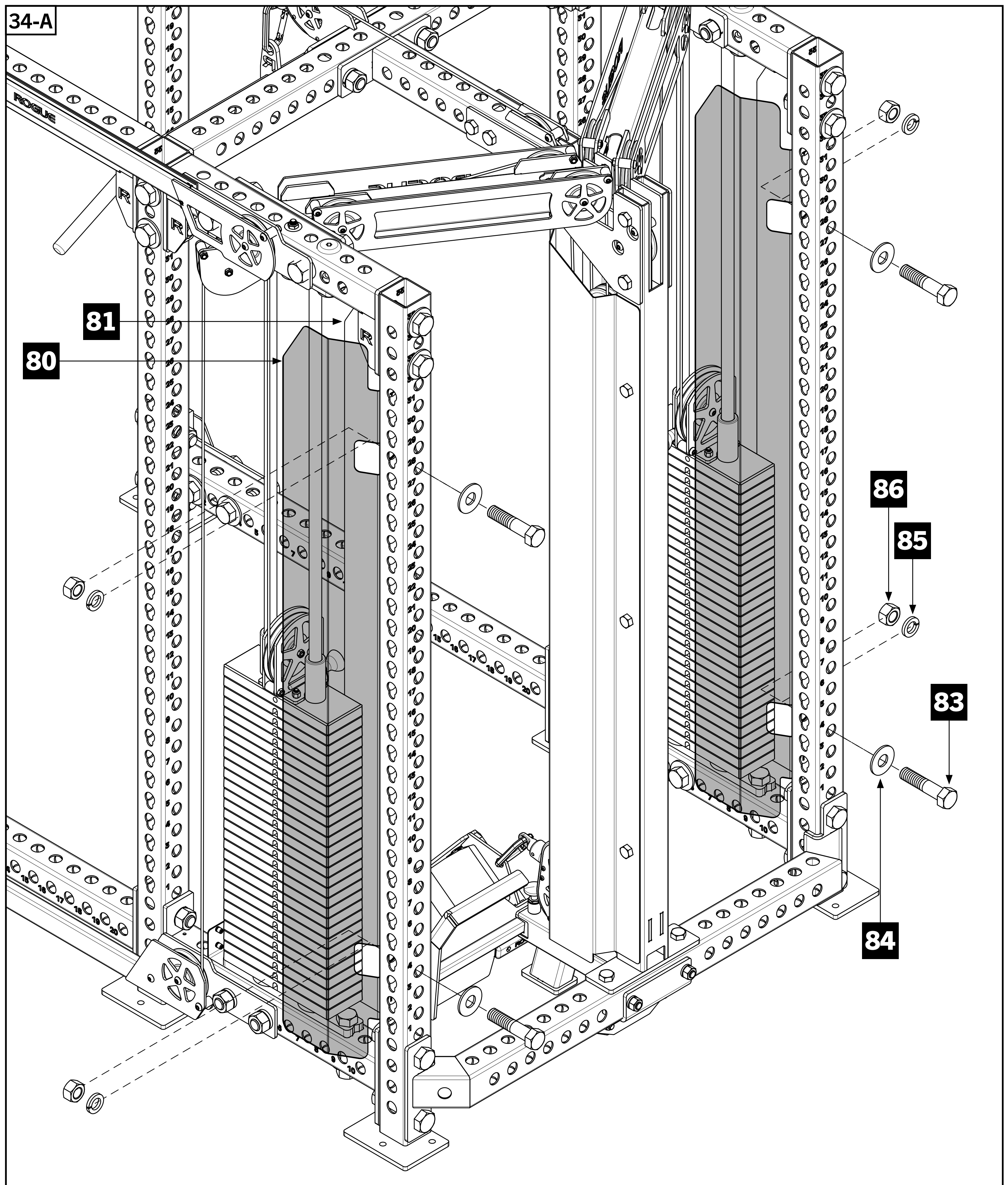
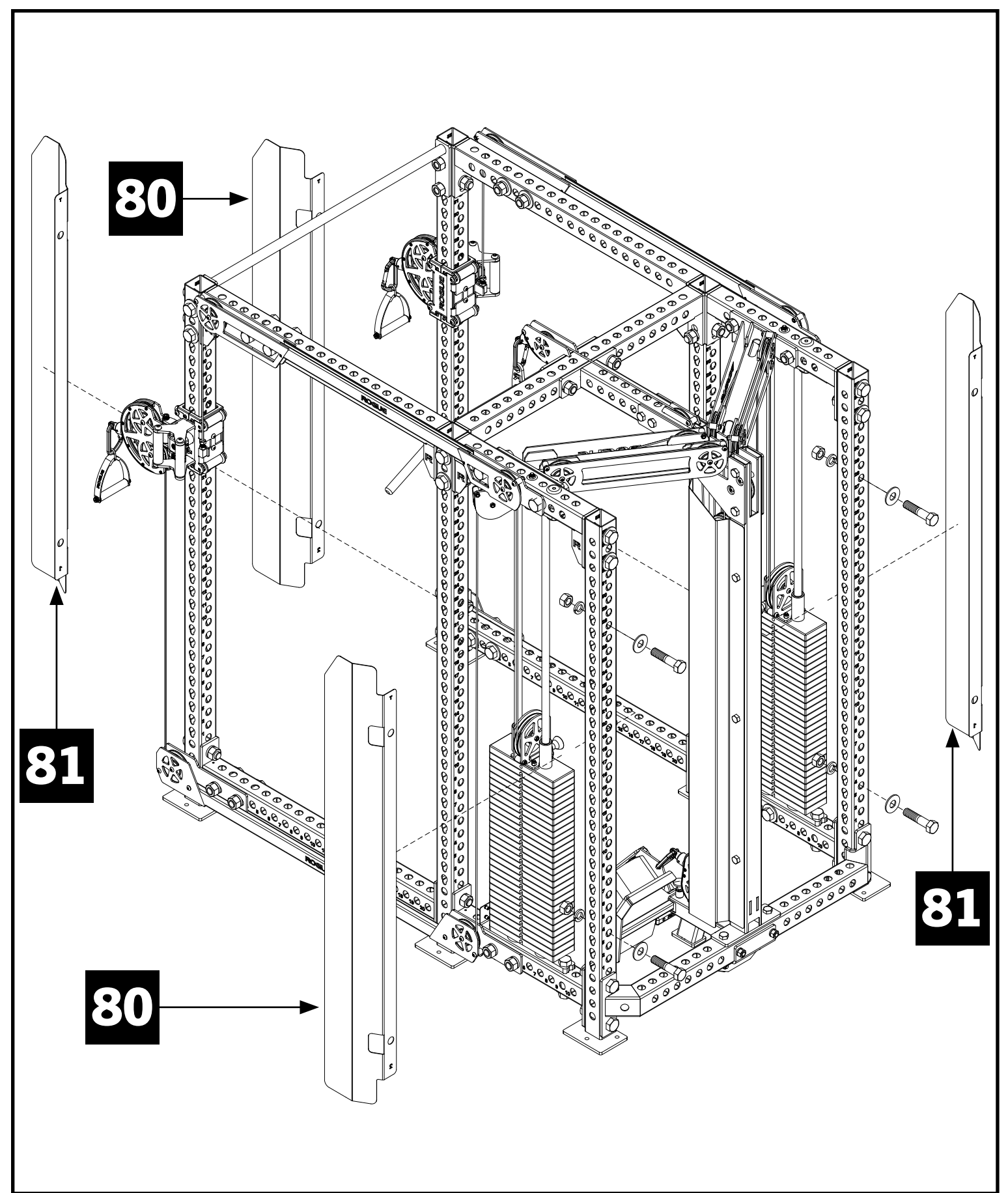

# STEP 35 (SHROUD ASSEMBLY)

## Tools Required:

- 1-1/2" Wrench, 5/32" Allen Key, 7/16" Wrench
- Attach Weight Stack Nameplate Shrouds [82] to Weight Stack Shroud Brackets [79] using 1/4" x 5/8" Button Head Screws [90].
- Fully tighten all Shroud Kit hardware.

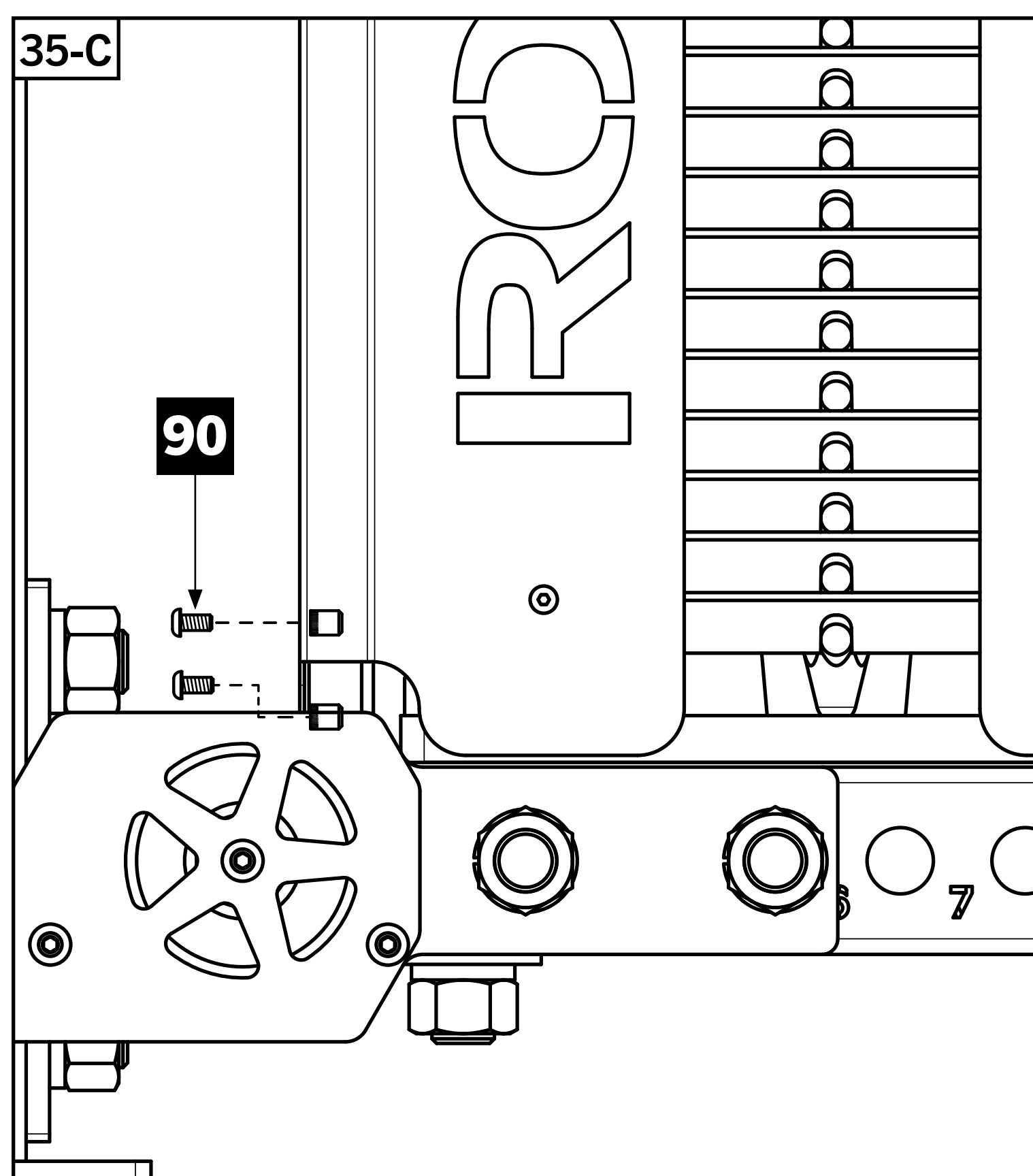
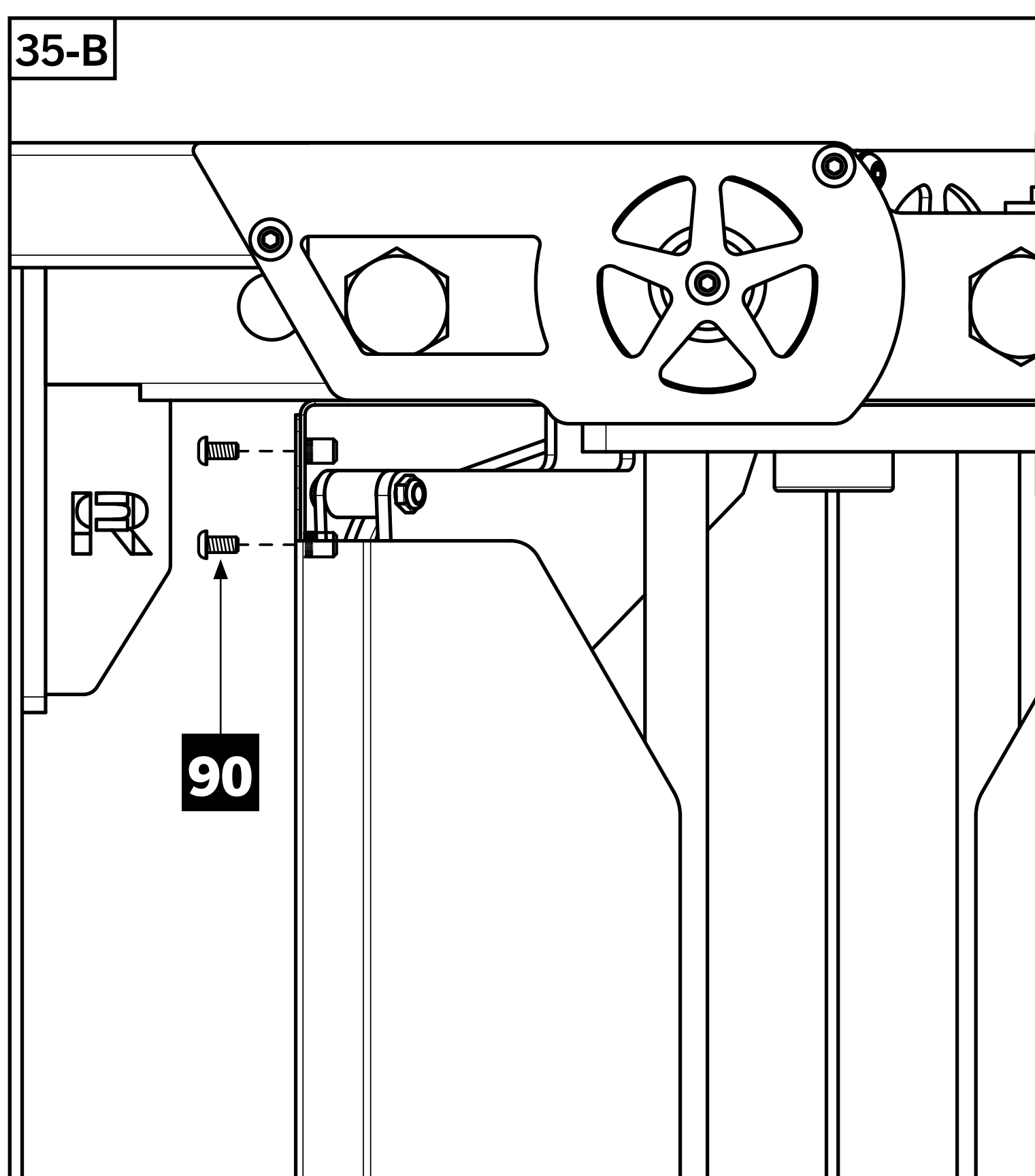
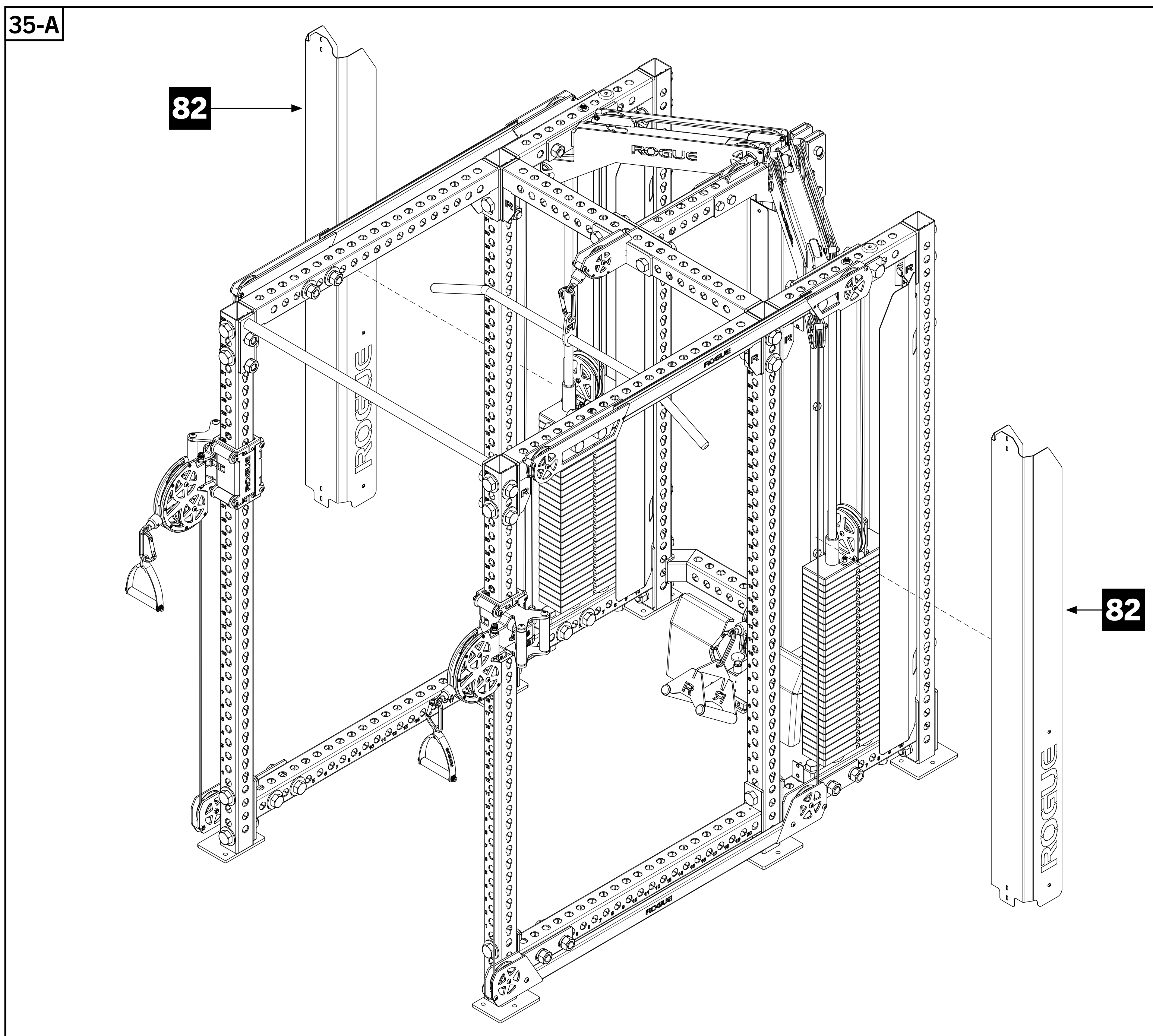

# INCLUDED MONSTER STRIP AND MONSTER HALF STRIPS

- \*Hardware and tools not included for installing Monster Strip and Half Strips [76].
- (4X) 3/8" x 2-1/2" Wood Lag Screws and (4X) 3/8" Flat Washers (not included) are recommended if mounting Strip to wall or wood stud.
- 15/64" Diameter drill bit recommended if using 3/8" Lag Screws.
- Identify stud in wall and mark desired height of top hole. Drill pilot hole in marked location.
- Put thread-side of screw through washer then screw through top hole at the back of the Strip into wall until wood but do not fully tighten.
- Let strip hang and ensure it is square using a level then mark locations of the 3 remaining holes.
- Hold strip to the side as shown in 32-B and drill pilot holes in the 3 marked locations.
- Put thread side of screw through the washer then screw through bottom 3/8" hole in back of Strip into the wall loosely.
- Screw in the remaining two Lag Screws and fully tighten all screws.
- If attempting to secure Strip to concrete or other material, the buyer is responsible for using correct hardware.
- It is the buyer's responsibility to install strip in a location and with hardware capable of supporting the aggregate weight of strip, all gear mounted or stored, and any person using it.
- If you are not confident in your mechanical skills, please seek the help of a professional to perform the installation.

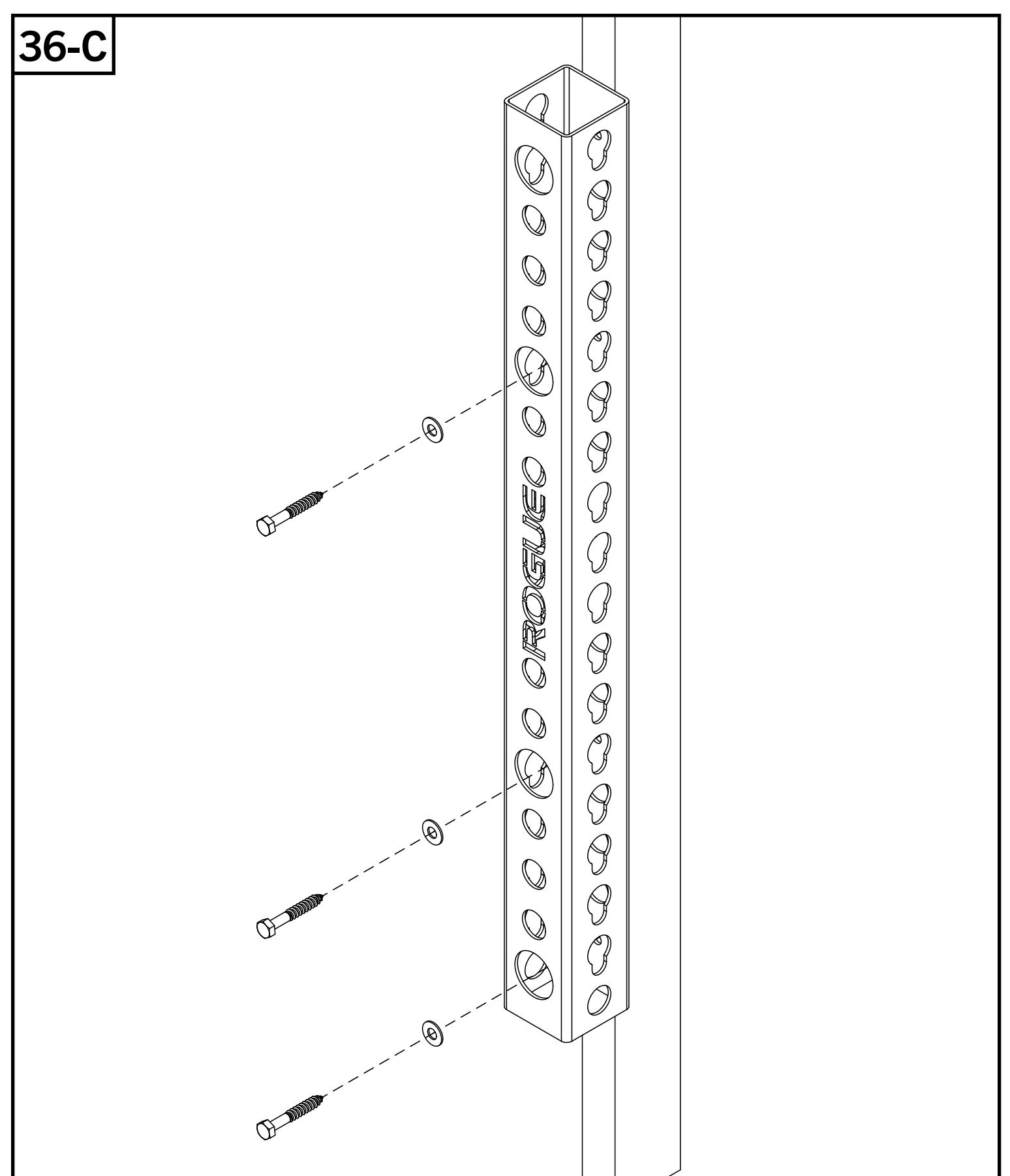
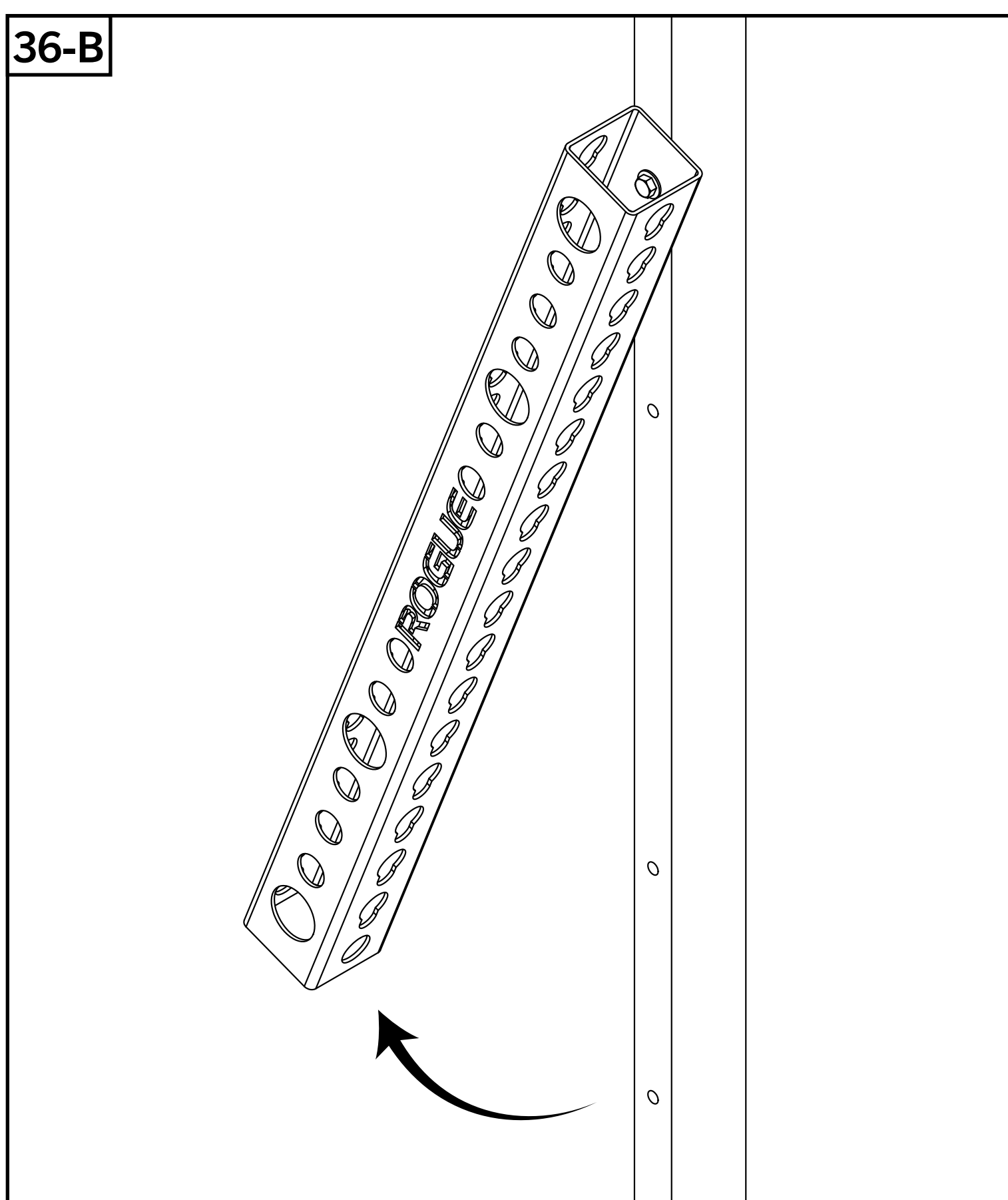
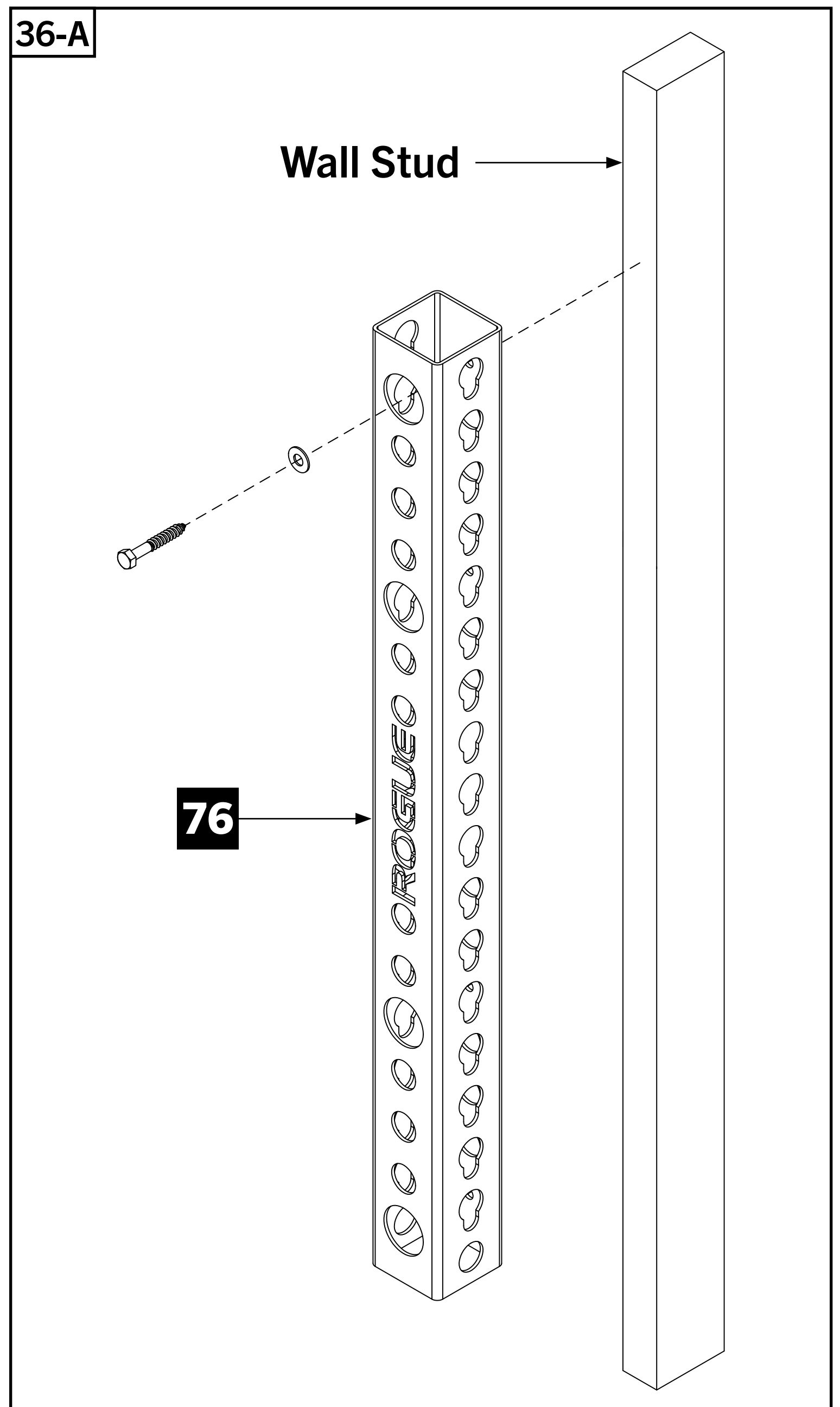
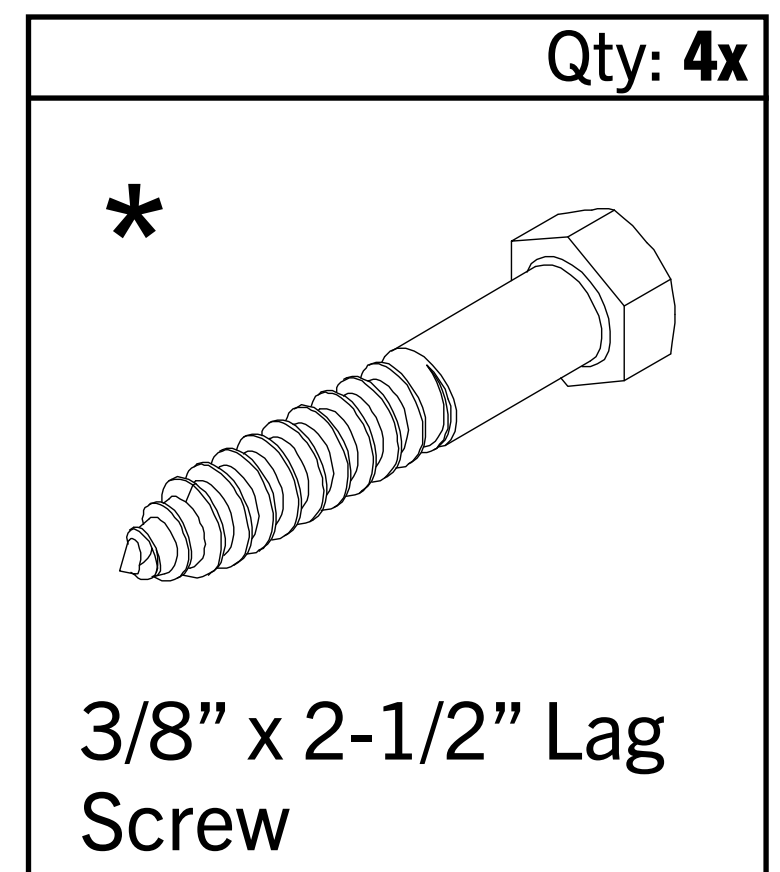
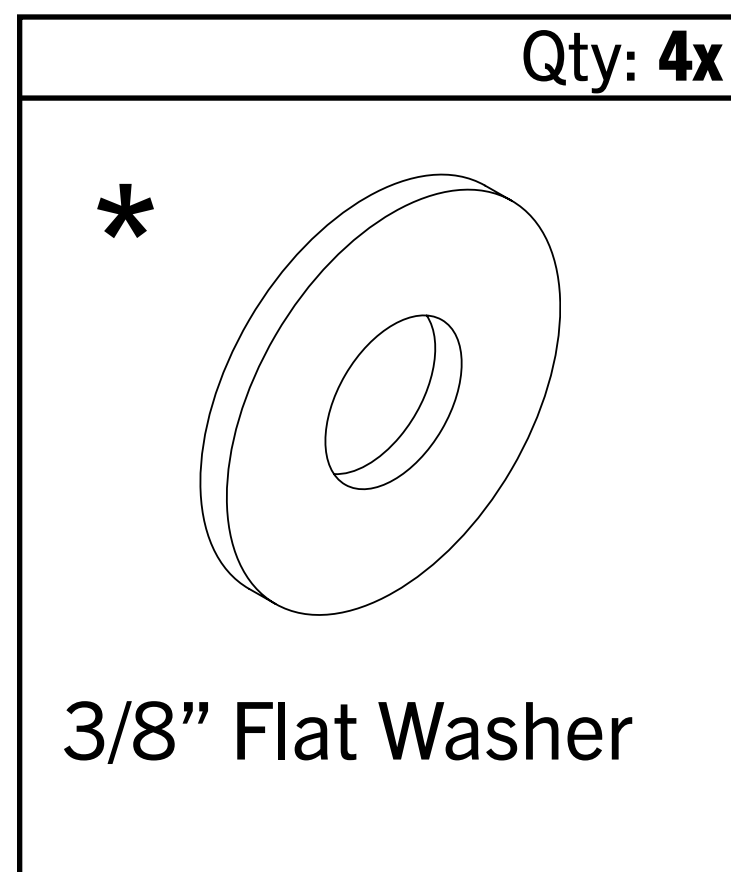

# CABLE MAINTENANCE

Over time, the cables within the system may experience some normal inelastic stretching. Follow the below instructions to re-tighten the cables.

## STEP 1

### Tools Required:

- Multi Tool
- Tighten both Trolley Cable bolt heads up towards the stop blocks on Swivel Trolleys.
- If cable system is tight, no further calibration is needed. If cables still have slack, proceed to **STEP 2**.

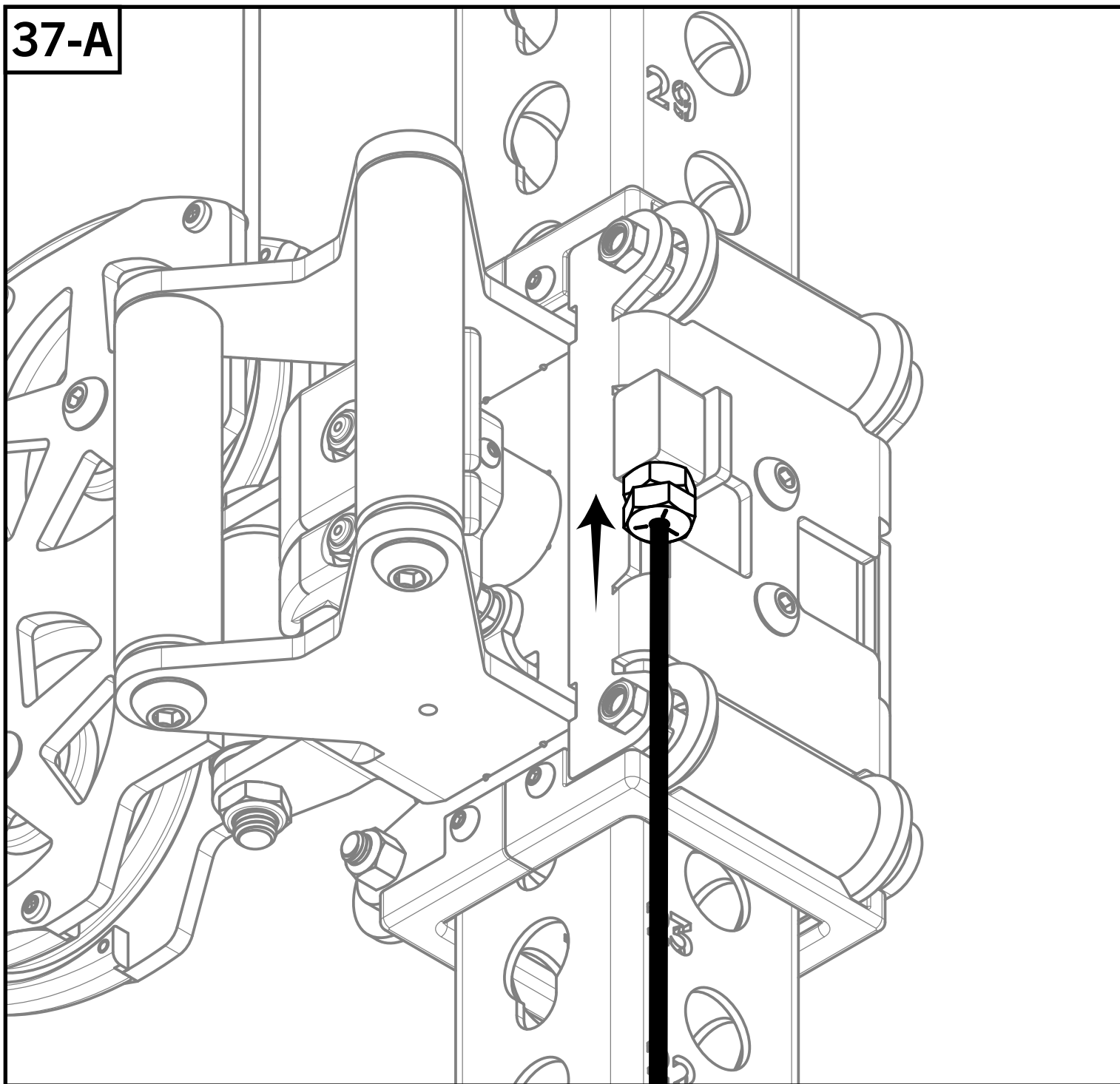

## STEP 2

### Tools Required:

- Multi Tool, 7/32" Allen Key
- Remove the Rear Center Shrouds.
- Remove Cable Retainers and hardware shown in **38-A** on Rear Pulley Assembly and move Pulley up by one hole.
- Re-adjust the height of the Trolley Cable Bolts to calibrate the cable tightness.

- If slack persists, continue moving Retainers and Pulley up by one hole and testing until cables are taught but not pulling up the weight stacks.

### Note:

- If installing pulley on the uppermost hole of Rear Pulley Assembly, the lower Cable Retainers are not needed.

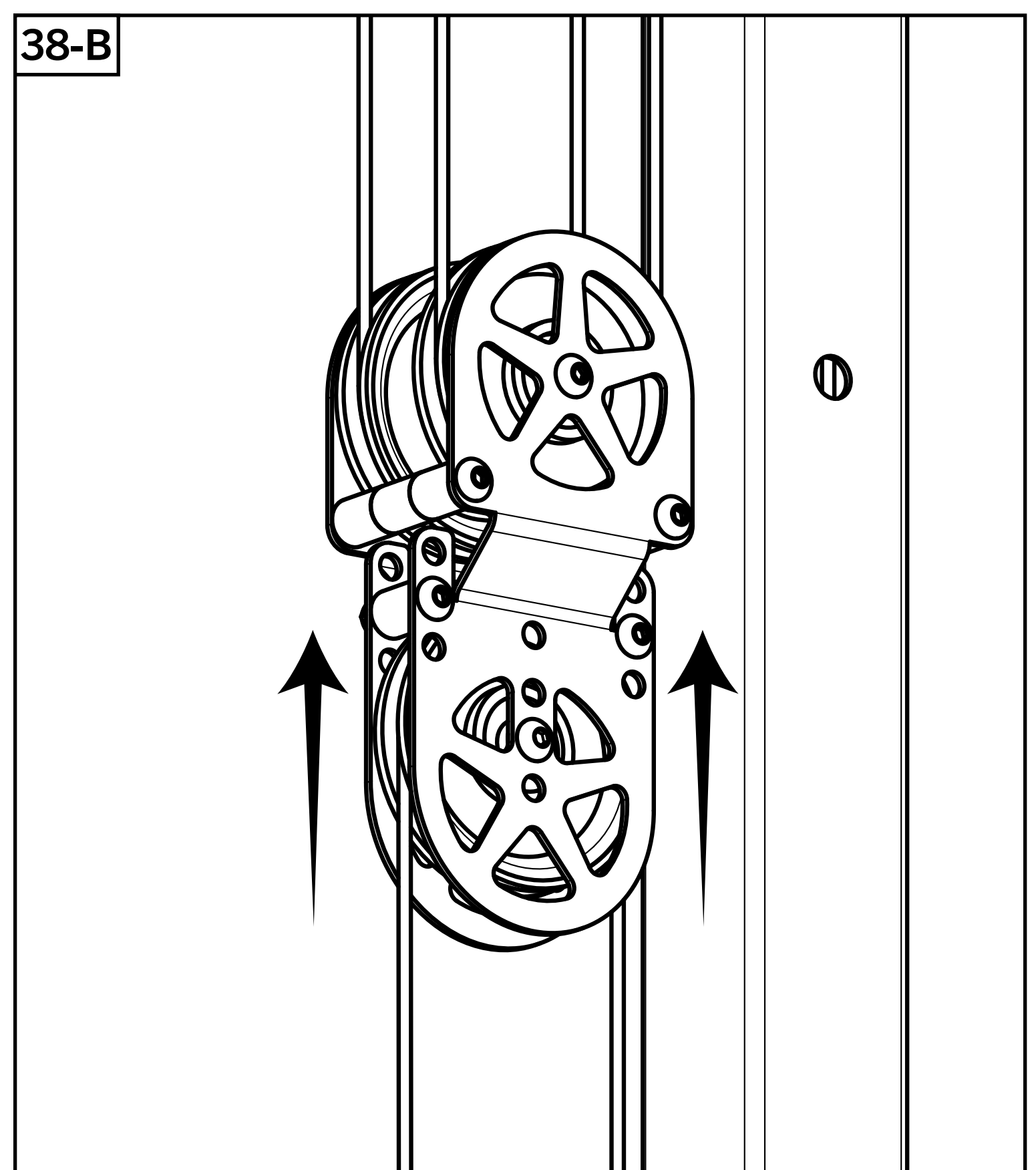
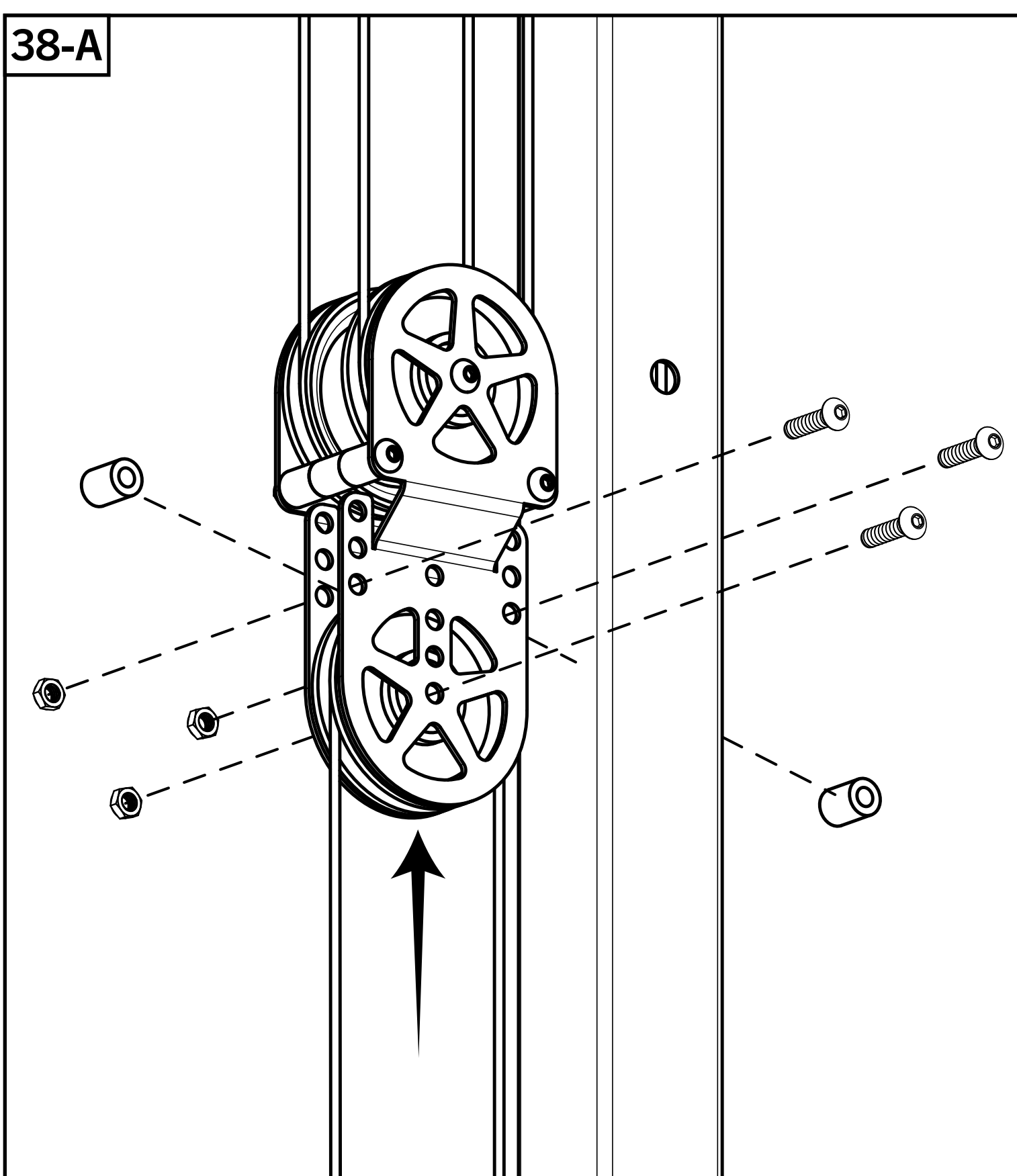



**ROGUE**



**SCAN FOR  
INSTRUCTIONS**



**IRON GAME  
PROGRAMMING**